

Key: 424

Town of E. BRIDGEWATER - Fiscal Year 2023

12/6/2022 6:38 pm SEQ #: 372

LEGALS AND

CURRENT OWNER				PARCEL ID				LOCATION			
LOCKHART SCOTT L & ROBIN M 18 BIXBY DR E BRIDGEWATER, MA 02333				7-545-0				18 BIXBY DR			
TRANSFER HISTORY				DOS	T	SALE PRICE	BK-PG (Cert)				
LOCKHART SCOTT L & ROBIN				06/30/1993	QS	110,000	11999-102				
SWARTZ IRENA				03/09/1992	A	100	10807-319				
SWARTZ IRENA				06/12/1985	QS		6145-305				

CLASS	CLASS%	DESCRIPTION			BN ID	BN	CARD	
1010	100	SINGLE FAMILY				1	1 of 1	
PMT NO	PMT DT	TY	DESC	AMOUNT	INSP	BY	1st	%
		6	CYCL GROWTH		09/25/2015	SD	0	0
		6	CYCL GROWTH		05/01/2013	LF	0	0
		6	CYCL GROWTH		10/25/2007		0	0

LEGALS AND

CD	T	AC/SF/UN	Ngh	Infl1	Infl2	ADJ BASE	SAF	Infl3	Lpi	VC	CREDIT AMT	ADJ VALUE				
100	S	6,098	2	1.00	100	1.00	100	1.00	205,390	5.91	PF	1.15	2	0.95		170,060

TOTAL	6,098 SF		ZONING	FRNT	0	ASSESSED	CURRENT	PREVIOUS
Ngh	RES 2	N C/W 546			LAND	170,100	154,700	
Infl1	FACTOR 100	O			BUILDING	178,300	166,500	
Infl2	PHY 100	T			DETACHED	2,500	2,300	
		E			OTHER	0	0	
					TOTAL	350,900	323,500	

DETACHED

TY	QUAL	COND	DIM/NOTE	YB	UNITS	ADJ PRICE	RCNLD	PHOTO
SHF	A	1.00	40 0.60		200	20.44	2,500	09/28/2015

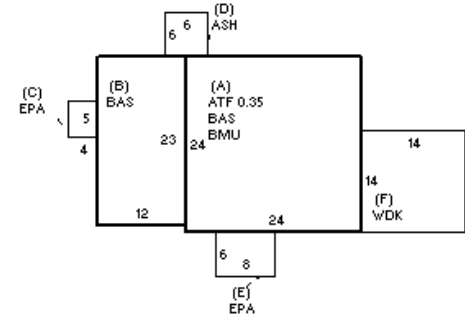

BUILDING	CD	ADJ	DESC	MEASURE	9/25/2015	SD
MODEL	1		RESIDENTIAL	LIST		
STYLE	1	1.00	RANCH [100%]	REVIEW	3/18/2013	ER
QUALITY	A	1.00	AVERAGE [100%]			
FRAME	1	1.00	WOOD FRAME [100%]			

BUILDING

YEAR BLT	1925	SIZE ADJ	1.000	ELEMENT	CD	DESCRIPTION	ADJ	S	BAT	T	DESCRIPTION	UNITS	YB	ADJ PRICE	RCN	TOTAL RCN	262,245
NET AREA	1,054	DETAIL ADJ	1.020	FOUNDATION	4	CONT BSMT WALL	1.00	A	BMU	N	BSMT UNFINISHED	576		47.05	27,103		
\$NLA(RCN)	\$249	OVERALL	1.000	EXT COVER	1	WD SHINGLES	1.00	A	ATF	L	ATTIC FINISH	202	1925	141.62	28,608		
				ROOF SHAPE	1	GABLE	1.00	+	BAS	L	BASE AREA	852	1925	218.91	186,508		
				ROOF COVER	1	ASP SHINGLES	1.00	+	EPA	N	ENCLOSED PORCH	68		74.40	5,059		
				FLOOR COVER	99	N/A	1.00	D	ASH	N	ATT SHED	36		18.75	675		
				INT FINISH	99	N/A	1.00	F	WDK	N	WOOD DECK	196		31.60	6,194		
				HEATING/COOLING	2	HOT WATER	1.02	F11	O		FPL 1S 1OP	1		6,017.00	6,017		
				FUEL SOURCE	99	N/A	1.00										
				ARPUD	0		1.00										
				AFFORDABLE	0		1.00										

CONDITION ELEM	CD
EXTERIOR	
INTERIOR	
KITCHEN	
BATHS	
HEAT	
ELECT	

EFF.YR/AGE	1970 / 51
COND	32 32 %
FUNC	0
ECON	0
DEPR	32 % GD 68
RCNLD	\$178,300