

Key: 4250

Town of E. BRIDGEWATER - Fiscal Year 2023

12/6/2022 6:38 pm SEQ #: 3.661

LEG
A
L

L
A
N
D

CURRENT OWNER				PARCEL ID				LOCATION					
MCCOLGAN JOHN F & JUDITH A				99-40-0				282 HARVARD ST					
292 HARVARD ST				TRANSFER HISTORY				DOS	T	SALE PRICE	BK-PG (Cert)		
E BRIDGEWATER, MA 02333				MCCOLGAN JOHN F & JUDITH				05/16/1977	QS		4266-174		

CLASS	CLASS%	DESCRIPTION			BN ID	BN	CARD	
1010	100	SINGLE FAMILY				1	1 of 1	
PMT NO	PMT DT	TY	DESC	AMOUNT	INSP	BY	1st	%
484A	11/24/2008	6	CYCL GROWTH		07/19/2021	SD	0	0
484B	11/24/2008	3	ALTERATIONS	1,000	08/28/2013	LF	0	0
		6	CYCL GROWTH		05/20/2009		0	0
		3	ALTERATIONS	1,000			0	0

CD	T	AC/SF/UN	Ngh	Inf1	Inf2	ADJ BASE	SAF	Inf3	Lpi	VC	CREDIT AMT	ADJ VALUE
100	S	24,800 3	1.00	100	100	188,000	1.61	100	1.00	3	1.00	171,810

TOTAL	24,800 SF	ZONING	FRNT	0	ASSESSED	CURRENT	PREVIOUS
Ngh	RES 3	N O T E	OWNER USES 292 HARVARD ST T 11807		LAND	171,800	156,300
Inf1	FACTOR 100		BUILDING	222,100	202,600		
Inf2	PHY 100		DETACHED	18,400	17,600		
			OTHER	0	0		
					TOTAL	412,300	376,500

TY	QUAL	COND	DIM/NOTE	YB	UNITS	ADJ PRICE	RCNLD
DGF	-	0.90 20 0.80			384	51.18	15,700
SHF	A	1.00 30 0.70	12X16	2008	192	20.44	2,700

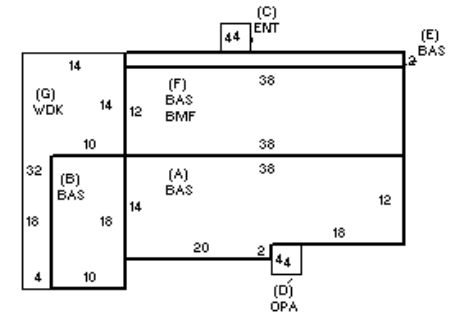

BUILDING	CD	ADJ	DESC	MEASURE	7/19/2021	SD
MODEL	1		RESIDENTIAL	LIST	7/19/2021	SD
STYLE	3	1.05	SPLIT LEVEL [100%]	REVIEW	4/16/2013	ER
QUALITY	A	1.00	AVERAGE [100%]			
FRAME	1	1.00	WOOD FRAME [100%]			

BLDG COMMENTS

D
E
T
A
C
H
E
D

B
U
I
L
D
I
N
G

YEAR BLT	1962	SIZE ADJ	1.000	ELEMENT	CD	DESCRIPTION	ADJ	S	BAT	T	DESCRIPTION	UNITS	YB	ADJ PRICE	RCN	TOTAL RCN	312,789
NET AREA	1,208	DETAIL ADJ	1.071	FOUNDATION	4	CONT BSMT WALL	1.00	+	BAS	L	BASE AREA	1,208	1962	215.86	260,758		
\$NLA(RCN)	\$259	OVERALL	1.000	EXT COVER	4	VINYL	1.00	C	ENT	N	ENCLOSED ENTRY	16		81.13	1,298		
				ROOF SHAPE	1	GABLE	1.00	D	OPA	N	OPEN PORCH	16		42.69	683		
				ROOF COVER	1	ASPH SHINGLES	1.00	F	BMF	N	BSMT FINISH-SEP	456		73.20	33,379		
				FLOOR COVER	99	N/A	1.00	G	WDK	N	WOOD DECK	268		31.60	8,469		
				INT FINISH	99	N/A	1.00		F11	O	FPL 1S 1OP	1		6,017.00	6,017		
				HEATING/COOLING	2	HOT WATER	1.02										
				FUEL SOURCE	99	N/A	1.00										
				ARPUD	0		1.00										
				AFFORDABLE	0		1.00										
																CONDITION ELEM	CD
																EXTERIOR	G
																INTERIOR	
																KITCHEN	
																BATHS	
																HEAT	U
																ELECT	
																EFF.YR/AGE	1974 / 47
																COND	29 29 %
																FUNC	0
																ECON	0
																DEPR	29 % GD 71
																RCNLD	\$222,100