

Key: 4423

Town of E. BRIDGEWATER - Fiscal Year 2023

12/6/2022 6:38 pm SEQ #: 3.808

LEG  
A  
L  
  
L  
A  
N  
D

CURRENT OWNER				PARCEL ID				LOCATION				
SIDIQUI JAMIL D & DUGGAN REBECCA A 293 WASHINGTON ST E BRIDGEWATER, MA 02333				106-7-0				293 WASHINGTON ST				
				TRANSFER HISTORY				DOS	T	SALE PRICE	BK-PG (Cert)	
				SIDIQUI JAMIL D & DRISCOLL THOMAS J & STACY CAVICCHI EDWARD G JR & MA				10/14/2011 08/26/2009 04/17/1984	N N QS	459,900 125,000 5616-235	40440-51 37654-208 5616-235	
CD	T	AC/SF/UN	Ngh	Inf1	Inf2	ADJ BASE	SAF	Inf3	Lpi	VC	CREDIT AMT	ADJ VALUE
100	S	43,560	3	1.00	100	1.00	100	1.00	1.00	3	188,000	188,000
300	A	8,025	3	1.00	100	1.00	100	1.00	1.00	3	13,470	13,470

CLASS	CLASS%	DESCRIPTION			BN ID	BN	CARD	
1010	100	SINGLE FAMILY				1	1 of 1	
PMT NO	PMT DT	TY	DESC	AMOUNT	INSP	BY	1st	%
BP-20-577	11/24/2020	3	ALTERATIONS	2,843				0
3004	07/22/2016	6	CYCL GROWTH	40,076	11/06/2020	SD		0
		3	ALTERATIONS					0
603	10/22/2010	51	FIELD REVIEW	500	09/16/2013	LS		0
		3	ALTERATIONS					0

TOTAL	9.025 Acres		ZONING	FRNT	0	ASSESSED	CURRENT	PREVIOUS
Ngh	RES 3		N O T E  T 13664/ excess wet	LAND		201,500	183,300	
Inf1	FACTOR 100			BUILDING		470,200	420,000	
Inf2	PHY 100			DETACHED		0	0	
				OTHER		0	0	
			TOTAL		671,700	603,300		

TY	QUAL	COND	DIM/NOTE	YB	UNITS	ADJ PRICE	RCNLD

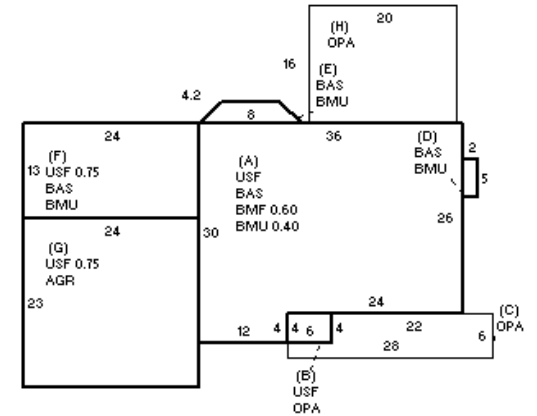

BLDG COMMENTS

D  
E  
T  
A  
C  
H  
E  
D

BUILDING	CD	ADJ	DESC	MEASURE	11/6/2020	SD
MODEL	1		RESIDENTIAL	LIST	11/6/2020	SD
STYLE	5	0.95	COLONIAL [100%]	REVIEW	4/18/2013	ER
QUALITY	A	1.00	AVERAGE [100%]			
FRAME	1	1.00	WOOD FRAME [100%]			

B  
U  
I  
L  
D  
I  
N  
G

YEAR BLT	2010	SIZE ADJ	1.000	ELEMENT	CD	DESCRIPTION	ADJ	S	BAT	T	DESCRIPTION	UNITS	YB	ADJ PRICE	RCN	TOTAL RCN	528,298
NET AREA	2,995	DETAIL ADJ	0.950	FOUNDATION	4	CONT BSMT WALL	1.00	+	BMU	N	BSMT UNFINISHED	749		36.05	27,004		
\$NLA(RCN)	\$176	OVERALL	1.000	EXT COVER	4	VINYL	1.00	A	BMF	N	BSMT FINISH-SEP	590		50.70	29,915		
				ROOF SHAPE	1	GABLE	1.00	+	BAS	L	BASE AREA	1,339	2010	140.34	187,909		
				ROOF COVER	1	ASPH SHINGLES	1.00	+	USF	L	UPPER STORY FIN	1,656	2010	127.53	211,184		
				FLOOR COVER	14	COMB	1.00	+	OPA	N	OPEN PORCH	488		42.70	20,838		
				INT FINISH	2	DRYWALL	1.00	G	AGR	N	ATT GARAGE	552		68.51	37,820		
				HEATING/COOLING	99	N/A	1.00	GFP	O	O	GAS FIREPLACE	1		4,584.00	4,584		
				FUEL SOURCE	2	GAS	1.00										
				ARPUD	0		1.00										
				AFFORDABLE	0		1.00										
																CONDITION ELEM	CD
																EXTERIOR	
																INTERIOR	
																KITCHEN	
																BATHS	
																HEAT	
																ELECT	
																EFF.YR/AGE	2010 / 11
																COND	11 11 %
																FUNC	0
																ECON	0
																DEPR	11 % GD 89
																RCNLD	\$470,200