

Key: 4604

Town of E. BRIDGEWATER - Fiscal Year 2023

12/6/2022 6:38 pm SEQ #: 3.923

LEG  
A  
L  
L  
A  
N  
D

CURRENT OWNER				PARCEL ID				LOCATION			
RIDDER FARM INC PO BOX 310 WHITMAN, MA 02382				114-1-0				390 OAK ST			
TRANSFER HISTORY				DOS	T	SALE PRICE		BK-PG (Cert)			
RIDDER FARM INC				12/29/2016	A	1 (124590)					
GEORGE RIDDER REALTY TRUS				12/31/1970	QS	0232-073					

CLASS	CLASS%	DESCRIPTION		BN ID	BN	CARD	
0380	100	Mixed-Comm/Chpt			1	1 of 7	
PMT NO	PMT DT	TY	DESC	AMOUNT	INSP	BY	1st %
3293	05/23/2017	3	ALTERATIONS	5,750	06/29/2017	RJM	100 100
2986	06/30/2016	3	ALTERATIONS	4,000	06/29/2017	RJM	100 100
NONE	05/20/2016	99	OTHER		06/29/2017	RJM	100 100
2905	05/03/2016	3	ALTERATIONS	300	06/29/2017	RJM	100 100
2876	04/01/2016	3	ALTERATIONS	20,000			100 100

CD	T	AC/SF/UN	Ngh	Infl1	Infl2	ADJ BASE	SAF	Infl3	Lpi	VC	CREDIT AMT	ADJ VALUE
103	S	87,120 C3	1.00	100	1.00	201,400	1.00	100	1.00	C3	1.00	402,800
203	A	45,000 C3	1.00	100	1.00	59,900	1.00	100	1.00	ELP	1.00	673,880
303	A	10,500 C3	1.00	100	1.00	8,300	1.00	100	1.00	C3	1.00	21,790

TOTAL	57.500 Acres	ZONING	FRNT	0	ASSESSED	CURRENT	PREVIOUS
Ngh	C3	N O T E FFCV-3259200. C/W 2 & 3 - RIDDER FARM. T 9831. .Variance Granted for new 60x90 tent			LAND	1,098,470	1,061,580
Infl1	FACTOR 100		BUILDING	223,000	213,400		
Infl2	PHY 100		DETACHED	349,000	331,800		
			OTHER	3,051,100	2,892,300		
				TOTAL	4,721,570	4,499,080	

TY	QUAL	COND	DIM/NOTE	YB	UNITS	ADJ PRICE	RCNLD
SW2	V	1.50	10 0.90	2-4X5	40	60.60	2,200
PAV	A	1.00	70 0.30		95,000	3.70	105,500
LH1	A	1.00	50 0.50		2	1,707.40	1,700
C06	A	1.00	70 0.30		500	18.40	2,800
DGM	A	1.00	30 0.70	60X60	3,600	45.18	113,900
UTB	E	1.80	10 0.90	2-20X30 RST	1,200	53.15	57,400
SW2	V	1.50	30 0.70	3X4	12	60.60	500
SHF	A	1.00	30 0.70	3-10X12	360	17.36	4,400
CAN	V	1.50	30 0.70	FR 20X100	2,000	8.74	12,200
LH2	A	1.00	50 0.50		1	2,684.70	1,300
SHF	V	1.50	30 0.70	5X6	30	30.66	600
W08	E	1.80	30 0.70	16X16 WST EN	64	28.80	1,300
DGF	A	1.00	30 0.70	28X42	1,176	46.55	38,300
GZB	A	1.00	10 0.90	10 X 10	100	32.20	2,900
SHF	A	1.00	10 0.90	12 X18	216	20.44	4,000



BUILDING	CD	ADJ	DESC	MEASURE	6/29/2017	RJM
MODEL	1		RESIDENTIAL	LIST	6/29/2017	RJM
STYLE	1	1.00	RANCH [91%]	REVIEW	7/25/2013	DF
QUALITY	+	1.05	AVG +/-GOOD - [100%]			
FRAME	1	1.00	WOOD FRAME [100%]			

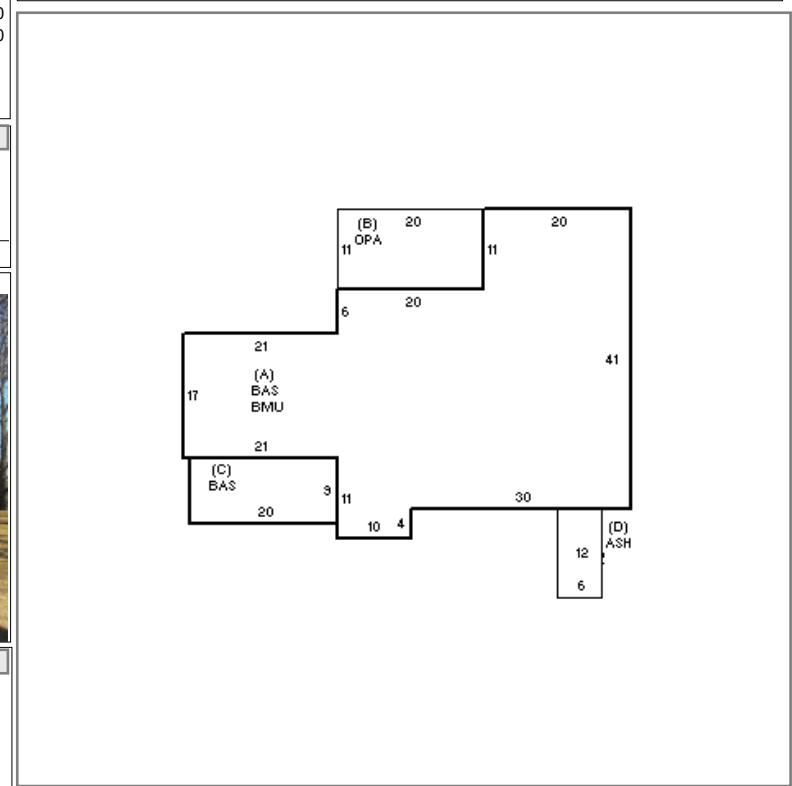

D  
E  
T  
A  
C  
H  
E  
D

B  
U  
I  
L  
D  
I  
N  
G

YEAR BLT	1940	SIZE ADJ	1.000	ELEMENT	CD	DESCRIPTION	ADJ	S	BAT	T	DESCRIPTION	UNITS	YB	ADJ PRICE	RCN	TOTAL RCN	445,982
NET AREA	1,997	DETAIL ADJ	1.019	FOUNDATION	4	CONT BSMT WALL	1.00	A	BMU	N	BSMT UNFINISHED	1,817		35.56	64,614		
\$NLA(RCN)	\$223	OVERALL	1.000	EXT COVER	7	STUCCO	0.98	A	BAS	L	BASE AREA	1,817	1940	177.44	322,407		
				ROOF SHAPE	1	GABLE	1.00	B	OPA	N	OPEN PORCH	220		44.84	9,864		
				ROOF COVER	8	TAR + GRAVEL	1.00	C	BAS	L	BASE AREA	180	1940	177.44	31,939		
				FLOOR COVER	1	HARDWOOD	1.00	D	ASH	N	ATT SHED	72		19.69	1,418		
				INT FINISH	1	PLASTER	1.00		FPL	O	FIREPLACE	2		6,779.35	13,559		
				HEATING/COOLING	11	HW/COOL AIR	1.04										
				FUEL SOURCE	1	OIL	1.00										
				ARPUD	0		1.00										
				AFFORDABLE	0		1.00										
																EFF.YR/AGE	1958 / 63
																COND	50 50 %
																FUNC	0
																ECON	0
																DEPR	50 % GD 50
																RCNLD	\$223,000

Key: 4604

Town of E. BRIDGEWATER - Fiscal Year 2023

12/6/2022 6:38 pm SEQ #: 3.924

LEGAL

CURRENT OWNER		PARCEL ID		LOCATION	
RIDDER FARM INC PO BOX 310 WHITMAN, MA 02382		114-1-0		390 OAK ST	
TRANSFER HISTORY		DOS	T	SALE PRICE	BK-PG (Cert)

CLASS	CLASS%	DESCRIPTION			BN ID	BN	CARD
0380	100	Mixed-Comm/Chpt				2	2 of 7
PMT NO	PMT DT	TY	DESC	AMOUNT	INSP	BY	1st %

LAND

CD	T	AC/SF/UN	Ngh	Inf1	Inf2	ADJ BASE	SAF	Inf3	Lpi	VC	CREDIT AMT	ADJ VALUE
----	---	----------	-----	------	------	----------	-----	------	-----	----	------------	-----------

TOTAL	ZONING	FRNT	ASSESSED	CURRENT	PREVIOUS
Ngh	NOTE		LAND	1,639,100	
Inf1		BUILDING			
Inf2		DETACHED			
			OTHER		
			TOTAL		

DETACHED

TY	QUAL	COND	DIM/NOTE	YB	UNITS	ADJ PRICE	RCNLD	PHOTO	07/25/2013
									

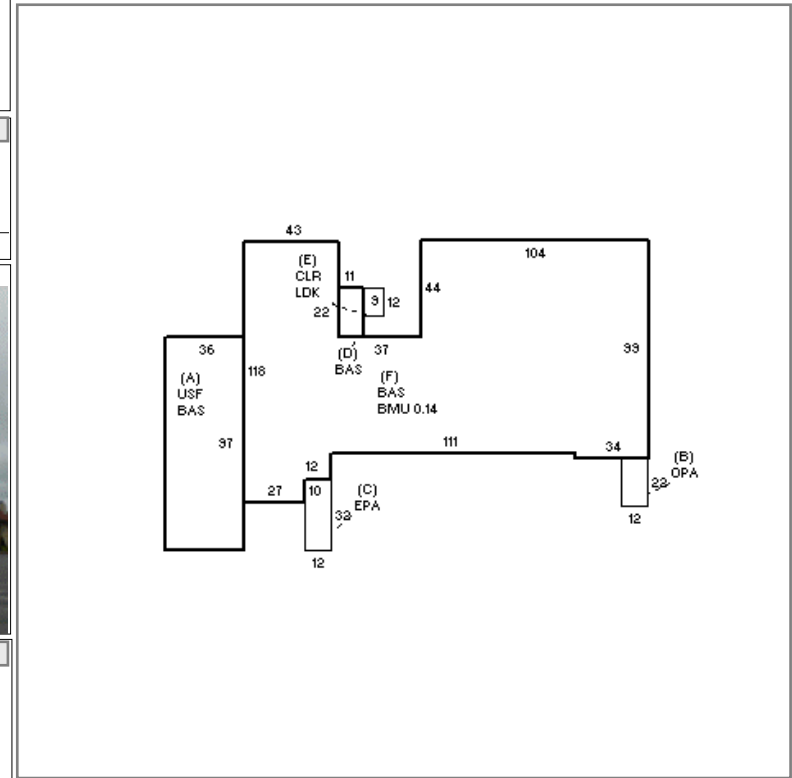

BUILDING

BUILDING	CD	ADJ	DESC	MEASURE		
MODEL	5		CIM-5	LIST		
STYLE	72	0.95	COUNTRY CLUB [100%]	REVIEW	1/1/2016	SLB
QUALITY	G	1.10	GOOD [100%]			
FRAME	1	1.00	WOOD FRAME [100%]			

BLDG COMMENTS  
RIDDER FARM. recheck for finished attic

LOADING

YEAR BLT	1928	SIZE ADJ	1.000	ELEMENT	CD	DESCRIPTION	ADJ	S	BAT	T	DESCRIPTION	UNITS	YB	ADJ PRICE	RCN	TOTAL RCN	2,980,235	
NET AREA	24,209	DETAIL ADJ	0.969	FOUNDATION	4	FLR & WALL	1.00	+	BAS	L	BASE AREA	20,475	1928	118.98	2,436,041	CONDITION ELEM	CD	
\$NLA(RCN)	\$123	OVERALL	1.000	EXT. COVER	7	STUCCO	1.00	A	USF	L	UP-STRY FIN	3,492	1928	118.98	415,465	EXTERIOR		
CAPACITY			UNITS	ADJ	ROOF SHAPE	4	FLAT/SHED	0.98	B	OPA	N	OPEN PORCH	264	26.29	6,941	INTERIOR		
STORIES	1	1.00	ROOF COVER	11	MEMBRANE	1.02	C	EPA	N	ENCL PORCH	384	34.76	13,348	CDN/APP				
% HEATED	100	1.00	FLOOR COVER	2	SOFTWOOD	0.95	D	BAS	L	BASE AREA	242	118.98	28,792					
% AIR COND	100	1.03	INT. FINISH	1	PLASTER	1.04	E	LDK	N	LOADING DOCK	108	29.10	3,143					
% SPRINKLER	100	1.02	HEATING/COOL	9	WARM/COOL AIR	1.00	E	CLR	N	COOLER	108	43.10	4,655					
			FUEL SOURCE	2	GAS	1.00	F	BMU	N	BSMT UNF	2,378	26.29	62,518					
			ARPUD	0		1.00	F11	O	FPL 1S 10P	2	4,666.00	9,332						
			AFFORDABLE	0		1.00											EFF.YR/AGE	1967 / 54
													COND	45	45%			
													FUNC	0				
													ECON	0				
													DEPR	45	% GD	55		
													RCNLD			\$1,639,100		

Key: 4604

Town of E. BRIDGEWATER - Fiscal Year 2023

12/6/2022 6:38 pm SEQ #: 3.925

LEGAL

CURRENT OWNER			PARCEL ID			LOCATION		
RIDDER FARM INC PO BOX 310 WHITMAN, MA 02382			114-1-0			390 OAK ST		
TRANSFER HISTORY			DOS	T	SALE PRICE	BK-PG (Cert)		

CLASS	CLASS%	DESCRIPTION			BN ID	BN	CARD
0380	100	Mixed-Comm/Chpt				3	3 of 7
PMT NO	PMT DT	TY	DESC	AMOUNT	INSP	BY	1st %

LAND

CD	T	AC/SF/UN	Ngh	Infl1	Infl2	ADJ BASE	SAF	Infl3	Lpi	VC	CREDIT AMT	ADJ VALUE
----	---	----------	-----	-------	-------	----------	-----	-------	-----	----	------------	-----------

TOTAL	ZONING	FRNT	ASSESSED	CURRENT	PREVIOUS
Ngh	NOTE		LAND BUILDING DETACHED OTHER TOTAL	122,800	
Infl1					
Infl2					

DETACHED

TY	QUAL	COND	DIM/NOTE	YB	UNITS	ADJ PRICE	RCNLD
----	------	------	----------	----	-------	-----------	-------

PHOTO 07/25/2013



(A) BAS	45.5	28
(B) BAS	45.5	34

BUILDING	CD	ADJ	DESC	MEASURE	REVIEW
MODEL	5		CIM-5	LIST	
STYLE	20	0.77	OFFICE BUILDING [55%]		
QUALITY	-	0.85	MINUS AVE [100%]		
FRAME	2	1.00	MASONRY [55%]		

YEAR BLT	1920 <th>SIZE ADJ</th> <td>1.000 <th>ELEMENT</th> <th>CD</th> <th>DESCRIPTION</th> <th>ADJ</th> <th>S</th> <th>BAT</th> <th>T</th> <th>DESCRIPTION</th> <th>UNITS</th> <th>YB</th> <th>ADJ PRICE</th> <th>RCN</th> </td>	SIZE ADJ	1.000 <th>ELEMENT</th> <th>CD</th> <th>DESCRIPTION</th> <th>ADJ</th> <th>S</th> <th>BAT</th> <th>T</th> <th>DESCRIPTION</th> <th>UNITS</th> <th>YB</th> <th>ADJ PRICE</th> <th>RCN</th>	ELEMENT	CD	DESCRIPTION	ADJ	S	BAT	T	DESCRIPTION	UNITS	YB	ADJ PRICE	RCN
NET AREA	2,821	DETAIL ADJ	0.731	FOUNDATION	2	SLAB	1.00	A	BAS	L	BASE AREA	1,274	1920	96.74	123,242
\$NLA(RCN)	\$97	OVERALL	1.000	EXT. COVER	13	STONE VENEER	1.07	B	BAS	L	BASE AREA	1,547	1920	96.74	149,650
				ROOF SHAPE	2	HIP	1.00								
				ROOF COVER	1	ASPH/CMP SHIN	1.00								
				FLOOR COVER	9	CONCRETE	0.95								
				INT. FINISH	6	MINIMUM	0.95								
				HEATING/COOL	1	FORCED AIR	1.00								
				FUEL SOURCE	2	GAS	1.00								
				ARPUD	0		1.00								
				AFFORDABLE	0		1.00								

TOTAL RCN 272,892

CONDITION ELEM	CD
EXTERIOR	
INTERIOR	
CDN/APP	

EFF.YR/AGE 1957 / 64

COND	55 55 %
FUNC	0
ECON	0
DEPR	55 % GD 45

RCNLD \$122,800

BUILDING

Key: 4604

Town of E. BRIDGEWATER - Fiscal Year 2023

12/6/2022 6:38 pm SEQ #: 3.926

LEGAL

CURRENT OWNER				PARCEL ID				LOCATION			
RIDDER FARM INC PO BOX 310 WHITMAN, MA 02382				114-1-0				390 OAK ST			
TRANSFER HISTORY				DOS	T	SALE PRICE		BK-PG (Cert)			

CLASS	CLASS%	DESCRIPTION				BN ID	BN	CARD	
0380	100	Mixed-Comm/Chpt					4	4 of 7	
PMT NO	PMT DT	TY	DESC	AMOUNT	INSP	BY	1st	%	

LAND

CD	T	AC/SF/UN	Ngh	Infl1	Infl2	ADJ BASE	SAF	Infl3	Lpi	VC	CREDIT AMT	ADJ VALUE

TOTAL	ZONING	FRNT	ASSESSED	CURRENT	PREVIOUS
Ngh	NOTE		LAND	336,300	
Infl1		BUILDING			
Infl2		DETACHED			
			OTHER		
			TOTAL		

DETACHED

TY	QUAL	COND	DIM/NOTE	YB	UNITS	ADJ PRICE	RCNLD



BLDG COMMENTS
STORAGE W/OFFICE

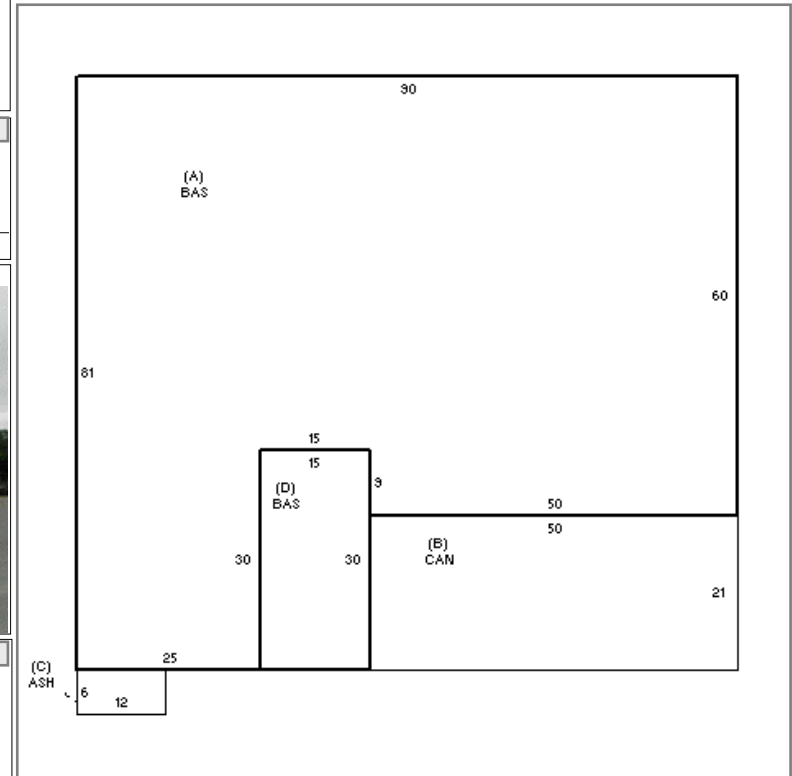

BUILDING

BUILDING	CD	ADJ	DESC	MEASURE	REVIEW
MODEL	5		CIM-5		
STYLE	56	0.64	WAREHOUSE [93%]	LIST	
QUALITY	A	1.00	AVERAGE [100%]	REVIEW	7/25/2013 DF
FRAME	4	0.98	METAL [100%]		

YEAR BLT	1987	SIZE ADJ	1.000
NET AREA	6,240	DETAIL ADJ	0.533
\$NLA(RCN)	\$72	OVERALL	1.000
CAPACITY		UNITS	ADJ
STORIES		1	1.00
% HEATED		100	1.00
% AIR COND		0	1.00
% SPRINKLER		0	1.00

ELEMENT	CD	DESCRIPTION	ADJ	S	BAT	T	DESCRIPTION	UNITS	YB	ADJ PRICE	RCN
FOUNDATION	2	SLAB	1.00	A	BAS	L	BASE AREA	5,790	1987	68.44	396,254
EXT. COVER	19	PREFAB METAL	1.00	B	CAN	N	CANOPY	1,050		18.90	19,845
ROOF SHAPE	1	GABLE	1.00	C	ASH	N	ATT SHED	72		21.50	1,548
ROOF COVER	10	METAL	1.00	D	BAS	L	BASE AREA	450	1987	68.44	30,797
FLOOR COVER	9	CONCRETE	0.95								
INT. FINISH	5	OTHER	1.00								
HEATING/COOL	15	SUSPENDED	0.95								
FUEL SOURCE	2	GAS	1.00								
ARPUD	0		1.00								
AFFORDABLE	0		1.00								

TOTAL RCN	448,444
CONDITION ELEM	CD
EXTERIOR	
INTERIOR	
CDN/APP	
EFF.YR/AGE	1992 / 29
COND	25 25%
FUNC	0
ECON	0
DEPR	25 % GD 75
RCNLD	\$336,300

Key: 4604

Town of E. BRIDGEWATER - Fiscal Year 2023

12/6/2022 6:38 pm SEQ #: 3.927

LEGAL

CURRENT OWNER		PARCEL ID	LOCATION		
RIDDER FARM INC PO BOX 310 WHITMAN, MA 02382		114-1-0	390 OAK ST		
TRANSFER HISTORY		DOS	T	SALE PRICE	BK-PG (Cert)

CLASS	CLASS%	DESCRIPTION			BN ID	BN	CARD	
0380	100	Mixed-Comm/Chpt				5	5 of 7	
PMT NO	PMT DT	TY	DESC	AMOUNT	INSP	BY	1st	%

LAND

CD	T	AC/SF/UN	Ngh	Infl1	Infl2	ADJ BASE	SAF	Infl3	Lpi	VC	CREDIT AMT	ADJ VALUE

TOTAL	ZONING	FRNT	ASSESSED	CURRENT	PREVIOUS
Ngh	NOTE		LAND	98,000	
Infl1		BUILDING			
Infl2		DETACHED			
			OTHER		
			TOTAL		

DETACHED

TY	QUAL	COND	DIM/NOTE	YB	UNITS	ADJ PRICE	RCNLD	PHOTO
								07/25/2013
								

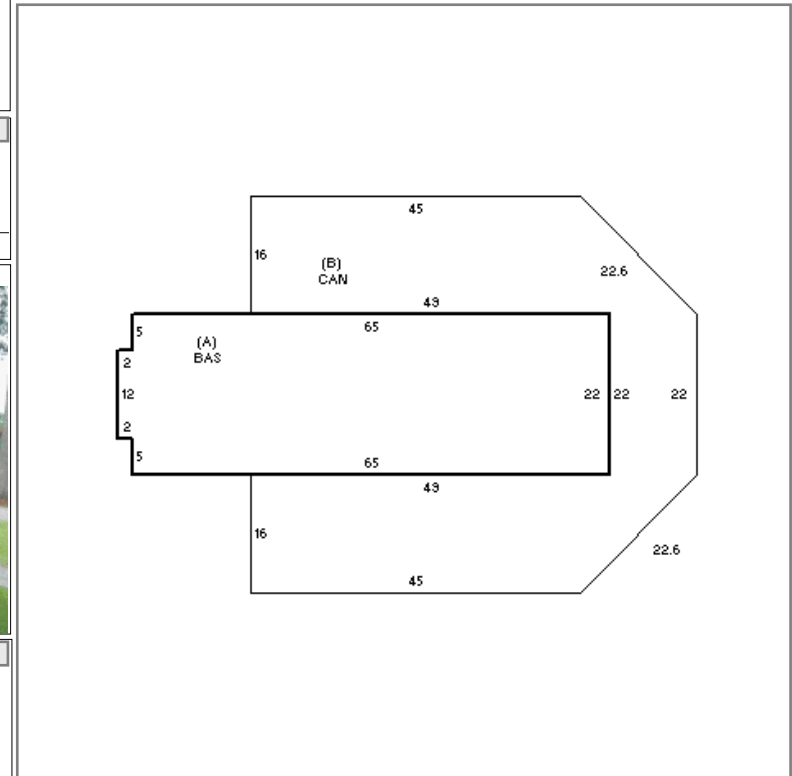

BUILDING

BUILDING	CD	ADJ	DESC	MEASURE	REVIEW	DATE	DF
MODEL	5		CIM-5	LIST			
STYLE	31	0.81	STORE [100%]	REVIEW	7/25/2013		DF
QUALITY	M	0.50	MINIMAL [100%]				
FRAME	1	1.00	WOOD FRAME [100%]				

YEAR BLT	1950	SIZE ADJ	1.000	ELEMENT	CD	DESCRIPTION	ADJ	S	BAT	T	DESCRIPTION	UNITS	YB	ADJ PRICE	RCN
NET AREA	1,454	DETAIL ADJ	0.824	FOUNDATION	2	SLAB	1.00	A	BAS	L	BASE AREA	1,454	1950	83.60	121,548
\$NLA(RCN)	\$96	OVERALL	1.000	EXT. COVER	10	VERT. BOARD	1.00	B	CAN	N	CANOPY	1,960		9.45	18,522
				ROOF SHAPE	1	GABLE	1.00								
				ROOF COVER	1	ASPH/CMP SHIN	1.00								
				FLOOR COVER	3	W/W CARPET	1.00								
				INT. FINISH	3	WOOD PANEL	1.05								
				HEATING/COOL	1	FORCED AIR	1.00								
				FUEL SOURCE	2	GAS	1.00								
				ARPUD	0		1.00								
				AFFORDABLE	0		1.00								

TOTAL RCN	140,070
CONDITION ELEM	CD
EXTERIOR	
INTERIOR	
CDN/APP	
EFF.YR/AGE 1983 / 38	
COND	30 30 %
FUNC	0
ECON	0
DEPR	30 % GD 70
RCNLD	\$98,000

Key: 4604

Town of E. BRIDGEWATER - Fiscal Year 2023

12/6/2022 6:38 pm SEQ #: 3.928

LEGAL

CURRENT OWNER		PARCEL ID		LOCATION	
RIDDER FARM INC PO BOX 310 WHITMAN, MA 02382		114-1-0		390 OAK ST	
TRANSFER HISTORY		DOS	T	SALE PRICE	BK-PG (Cert)

CLASS	CLASS%	DESCRIPTION			BN ID	BN	CARD	
0380	100	Mixed-Comm/Chpt				6	6 of 7	
PMT NO	PMT DT	TY	DESC	AMOUNT	INSP	BY	1st	%

LAND

CD	T	AC/SF/UN	Ngh	Infl1	Infl2	ADJ BASE	SAF	Infl3	Lpi	VC	CREDIT AMT	ADJ VALUE

TOTAL	ZONING	FRNT	ASSESSED	CURRENT	PREVIOUS
Ngh	NOTE		LAND	594,500	
Infl1		BUILDING			
Infl2		DETACHED			
			OTHER		
			TOTAL		

DETACHED

TY	QUAL	COND	DIM/NOTE	YB	UNITS	ADJ PRICE	RCNLD



BLDG COMMENTS
CAMERON'S ON THE GREEN

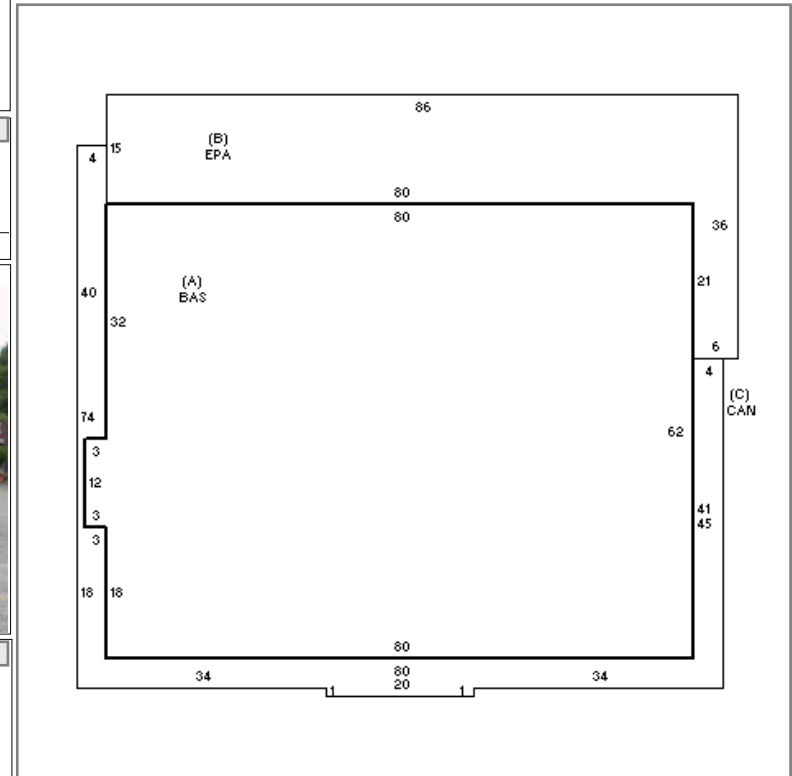

BUILDING

BUILDING	CD	ADJ	DESC	MEASURE	REVIEW	7/25/2013	DF
MODEL	5		CIM-5	LIST			
STYLE	39	1.05	RESTAURANT [100%]				
QUALITY	A	1.00	AVERAGE [100%]				
FRAME	1	1.00	WOOD FRAME [100%]				

YEAR BLT	1996	SIZE ADJ	1.000	ELEMENT	CD	DESCRIPTION	ADJ	S	BAT	T	DESCRIPTION	UNITS	YB	ADJ PRICE	RCN	TOTAL RCN	772.037		
NET AREA	4,996	DETAIL ADJ	1.064	FOUNDATION	2	SLAB	1.00	A	BAS	L	BASE AREA	4,996	1996	142.62	712,549	CONDITION ELEM	CD		
\$NLA(RCN)	\$155	OVERALL	1.000	EXT. COVER	2	CLAPBOARD	1.00	B	EPA	N	ENCL PORCH	1,416		31.60	44,746	EXTERIOR			
				ROOF SHAPE	2	HIP	1.00	C	CAN	N	CANOPY	780		18.90	14,742	INTERIOR			
				ROOF COVER	1	ASPH/CMP SHIN	1.00											CDN/APP	
				FLOOR COVER	4	TILE	0.98												
				INT. FINISH	2	DRYWALL	1.00												
				HEATING/COOL	9	WARM/COOL AIR	1.00												
				FUEL SOURCE	2	GAS	1.00												
				ARPUD	0		1.00												
				AFFORDABLE	0		1.00												
																		EFF.YR/AGE	1996 / 25
																		COND	23 23 %
																		FUNC	0
																		ECON	0
																		DEPR	23 % GD 77
																		RCNLD	\$594,500

Key: 4604

Town of E. BRIDGEWATER - Fiscal Year 2023

12/6/2022 6:38 pm SEQ #: 3.929

LEGAL

CURRENT OWNER		PARCEL ID		LOCATION	
RIDDER FARM INC PO BOX 310 WHITMAN, MA 02382		114-1-0		390 OAK ST	
TRANSFER HISTORY		DOS	T	SALE PRICE	BK-PG (Cert)

CLASS	CLASS%	DESCRIPTION			BN ID	BN	CARD
0380	100	Mixed-Comm/Chpt				7	7 of 7
PMT NO	PMT DT	TY	DESC	AMOUNT	INSP	BY	1st %

LAND

CD	T	AC/SF/UN	Ngh	Inf1	Inf2	ADJ BASE	SAF	Inf3	Lpi	VC	CREDIT AMT	ADJ VALUE
----	---	----------	-----	------	------	----------	-----	------	-----	----	------------	-----------

TOTAL	ZONING	FRNT	ASSESSED	CURRENT	PREVIOUS
Ngh	NOTE		LAND	260,400	
Inf1		BUILDING			
Inf2		DETACHED			
			OTHER		
			TOTAL		

DETACHED

TY	QUAL	COND	DIM/NOTE	YB	UNITS	ADJ PRICE	RCNLD	PHOTO	04/06/2021
									

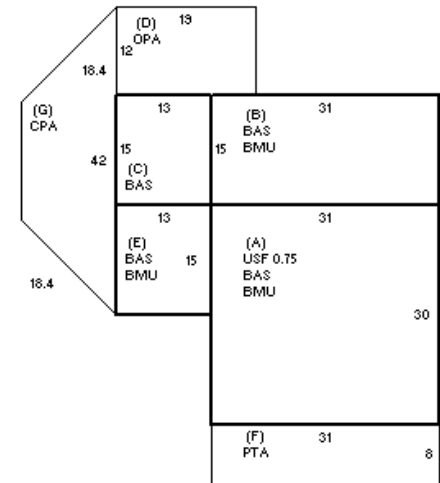

BUILDING

BUILDING	CD	ADJ	DESC	MEASURE		
MODEL	1		RESIDENTIAL	LIST		
STYLE	7	0.90	CONVENTIONAL [100%]	REVIEW	7/25/2013	DF
QUALITY	G	1.15	GOOD [100%]			
FRAME	1	1.00	WOOD FRAME [100%]			

YEAR BLT	0	SIZE ADJ	1.000	ELEMENT	CD	DESCRIPTION	ADJ	S	BAT	T	DESCRIPTION	UNITS	YB	ADJ PRICE	RCN	TOTAL RCN	500,756	
NET AREA	2,483	DETAIL ADJ	0.944	FOUNDATION	4	CONT BSMT WALL	1.00	+	BMU	N	BSMT UNFINISHED	1,590		39.94	63,512	CONDITION ELEM	CD	
\$NLA(RCN)	\$202	OVERALL	1.000	EXT COVER	7	STUCCO	0.98	A	USF	L	UPPER STORY FIN	698	0	153.12	106,876	EXTERIOR	F	
				ROOF SHAPE	1	GABLE	1.00	+	BAS	L	BASE AREA	1,785	0	168.50	300,770	INTERIOR	F	
				ROOF COVER	6	TILE	1.05	D	OPA	N	OPEN PORCH	228		49.11	11,196	KITCHEN	F	
				FLOOR COVER	1	HARDWOOD	1.00	F	PTA	N	PATIO	248		14.38	3,565	BATHS	F	
				INT FINISH	1	PLASTER	1.00	G	CPA	N	CAR PORT	377		19.66	7,412	HEAT	O	
				HEATING/COOLING	2	HOT WATER	1.02	F	FPL	O	FIREPLACE	1		7,424.40	7,424	ELECT	O	
				FUEL SOURCE	1	OIL	1.00											
				ARPUD	0		1.00											
				AFFORDABLE	0		1.00											

EFF.YR/AGE	1959 / 62
COND	48 48 %
FUNC	0
ECON	0
DEPR	48 % GD 52
RCNLD	\$260,400