

Key: 4857

Town of E. BRIDGEWATER - Fiscal Year 2023

12/6/2022 6:38 pm SEQ #: 4.141

LEG  
AL  
LAND

CURRENT OWNER				PARCEL ID				LOCATION			
FRANCIOSA DIANE T & SARAH C 48 OAKWOOD TERR E BRIDGEWATER, MA 02333				127-30-0				48 OAKWOOD TER			
TRANSFER HISTORY				DOS	T	SALE PRICE	BK-PG (Cert)				
FRANCIOSA DIANE T & SARAH				06/24/2020	QS	360,500	52961-151				
HEAP ROBERT D JR & JENNIF				12/21/2005	A	1	31950-225				
HEAP ROBERT D JR				08/21/1997	A	1	15415-081				

CLASS	CLASS%	DESCRIPTION			BN ID	BN	CARD	
1010	100	SINGLE FAMILY				1	1 of 1	
PMT NO	PMT DT	TY	DESC	AMOUNT	INSP	BY	1st	%
		6	CYCL GROWTH		01/14/2021	SD	0	0
		6	CYCL GROWTH		09/10/2020	SD	0	0
		5	SPLIT/SUB		09/09/2013	LF	0	0

CD	T	AC/SF/UN	Ngh	Inf1	Inf2	ADJ BASE	SAF	Inf3	Lpi	VC	CREDIT AMT	ADJ VALUE
100	S	27,500	3	1.00	100	1.00	100	1.00	3	1.00		174,140

TOTAL	27,500 SF	ZONING	FRNT	0	ASSESSED	CURRENT	PREVIOUS
Ngh	RES 3	NOTE LOT 9/ UTILITY ESMT			LAND	174,100	158,400
Inf1	FACTOR 100		BUILDING	223,900	204,500		
Inf2	PHY 100		DETACHED	11,900	11,300		
			OTHER	0	0		
					<b>TOTAL</b>	<b>409,900</b>	<b>374,200</b>

TY	QUAL	COND	DIM/NOTE	YB	UNITS	ADJ PRICE	RCNLD
SHF	A	1.00	40 0.60	1996	200	20.44	2,500
IPV	A	1.00	20 0.80	1996	576	20.49	9,400

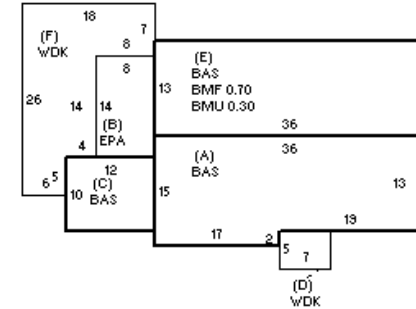

BUILDING	CD	ADJ	DESC	MEASURE	9/10/2020	SD
MODEL	1		RESIDENTIAL	LIST	9/10/2020	SD
STYLE	3	1.05	SPLIT LEVEL [100%]	REVIEW	4/19/2013	ER
QUALITY	A	1.00	AVERAGE [100%]			
FRAME	1	1.00	WOOD FRAME [100%]			

BLDG COMMENTS

YEAR BLT	1966	SIZE ADJ	1.000	ELEMENT	CD	DESCRIPTION	ADJ	S	BAT	T	DESCRIPTION	UNITS	YB	ADJ PRICE	RCN	TOTAL RCN	306,750
NET AREA	1,090	DETAIL ADJ	1.081	FOUNDATION	4	CONT BSMT WALL	1.00	+	BAS	L	BASE AREA	1,090	1966	228.23	248,773		
\$NLA(RCN)	\$281	OVERALL	1.000	EXT COVER	4	VINYL	1.00	B	EPA	N	ENCLOSED PORCH	112		74.40	8,333		
				ROOF SHAPE	1	GABLE	1.00	+	WDK	N	WOOD DECK	331		31.60	10,460		
				ROOF COVER	1	ASPH SHINGLES	1.00	E	BMU	N	BSMT UNFINISHED	140		51.49	7,209		
				FLOOR COVER	99	N/A	1.00	E	BMF	N	BSMT FINISH-SEP	328		72.42	23,753		
				INT FINISH	99	N/A	1.00	F11	O		FPL 1S 1OP	1		6,017.00	6,017		
				HEATING/COOLING	9	WARM/COOL AIR	1.03										
				FUEL SOURCE	99	N/A	1.00										
				ARPUD	0		1.00										
				AFFORDABLE	0		1.00										

CONDITION ELEM	CD
EXTERIOR	
INTERIOR	
KITCHEN	
BATHS	
HEAT	
ELECT	

EFF.YR/AGE	1980 / 41
COND	27 27 %
FUNC	0
ECON	0
DEPR	27 % GD 73
RCNLD	\$223,900