

Key: 4897

Town of E. BRIDGEWATER - Fiscal Year 2023

12/6/2022 6:38 pm SEQ #: 4.176

LEGALS

CURRENT OWNER				PARCEL ID				LOCATION				
MAVILIA ROBERT A JR & CHRISTINE M 10 PHEASANT RUN E BRIDGEWATER, MA 02333				70-1-12-0				10 PHEASANT RUN				
				TRANSFER HISTORY				DOS	T	SALE PRICE	BK-PG (Cert)	
				MAVILIA ROBERT A JR & DAVISON F W & LISA				05/29/2009	QS	415,000	37274-097	
				DAVISON FREDERICK W & LIS				02/16/2005	A	1	30005-276	
								06/27/1997	D		15281-125	

CLASS	CLASS%	DESCRIPTION			BN ID	BN	CARD	
1010	100	SINGLE FAMILY				1	1 of 1	
PMT NO	PMT DT	TY	DESC	AMOUNT	INSP	BY	1st	%
BP-21-132	04/01/2021	8	POOL	37,000	05/17/2021	SLB	100	100
2041	06/05/2014	8	POOL	5,000			0	0
		6	CYCL GROWTH		08/19/2013	LF	0	0
1984	01/11/2001	1	NEW CONST	13,000	08/06/2002	SLB	100	0

LAND

CD	T	AC/SF/UN	Ngh	Inf1	Inf2	ADJ BASE	SAF	Inf3	Lpi	VC	CREDIT AMT	ADJ VALUE
100	S	39,521	4	1.00	100	1.00	100	1.00	4	1.20		221,420

TOTAL	39,521 SF	ZONING	FRNT	0	ASSESSED	CURRENT	PREVIOUS
Ngh	RES 4	NOTE	LAND	221,400	184,600		
Inf1	FACTOR 100		BUILDING	369,500	325,800		
Inf2	PHY 100		DETACHED	11,400	10,800		
			OTHER	0	0		
				<b>TOTAL</b>	<b>602,300</b>	<b>521,200</b>	

DETACHED

TY	QUAL	COND	DIM/NOTE	YB	UNITS	ADJ PRICE	RCNLD	PHOTO	05/17/2021
IPV	A	1.00	10 0.90	18 X 36	2021	648	19.48	11,400	

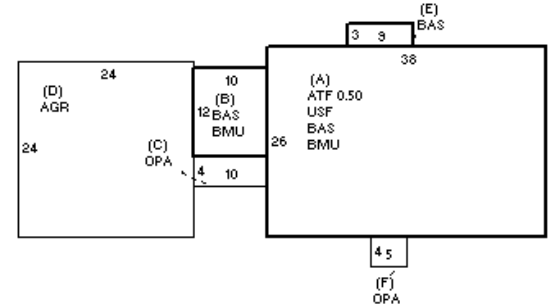

BUILDING	CD	ADJ	DESC	MEASURE	5/17/2021	SLB
MODEL	1		RESIDENTIAL	LIST	5/17/2021	SLB
STYLE	5	0.95	COLONIAL [100%]	REVIEW	4/22/2013	ER
QUALITY	+	1.05	AVG +/GOOD - [100%]			
FRAME	1	1.00	WOOD FRAME [100%]			

BUILDING

YEAR BLT	1997	SIZE ADJ	1.000	ELEMENT	CD	DESCRIPTION	ADJ	S	BAT	T	DESCRIPTION	UNITS	YB	ADJ PRICE	RCN	TOTAL RCN	473,766		
NET AREA	2,617	DETAIL ADJ	0.988	FOUNDATION	4	CONT BSMT WALL	1.00	+	BMU	N	BSMT UNFINISHED	1,108		39.68	43,963	CONDITION ELEM	CD		
\$NLA(RCN)	\$181	OVERALL	1.000	EXT COVER	2	CLAPBOARD	1.00	A	USF	L	UPPER STORY FIN	988	1997	144.19	142,456	EXTERIOR			
				ROOF SHAPE	1	GABLE	1.00	A	ATF	L	ATTIC FINISH	494	1997	102.65	50,710	INTERIOR			
				ROOF COVER	1	ASPH SHINGLES	1.00	+	OPA	N	OPEN PORCH	60		44.84	2,690	KITCHEN			
				FLOOR COVER	99	N/A	1.00	D	AGR	N	ATT GARAGE	576		71.28	41,056	BATHS			
				INT FINISH	99	N/A	1.00	+	BAS	L	BASE AREA	1,135	1997	158.67	180,088	HEAT			
				HEATING/COOLING	11	HW/COOL AIR	1.04	F21	O	O	FPL 2S 1OP	1		7,160.00	7,160	ELECT			
				FUEL SOURCE	99	N/A	1.00												
				ARPUD	0		1.00												
				AFFORDABLE	0		1.00												
																EFF.YR/AGE	1997 / 24		
																COND	22 22 %		
																FUNC	0		
																ECON	0		
																DEPR	22	% GD	78
																RCNLD	\$369,500		