

Key: 4898

Town of E. BRIDGEWATER - Fiscal Year 2023

12/6/2022 6:38 pm SEQ #: 4.177

LEGALS

CURRENT OWNER				PARCEL ID				LOCATION			
JAKOWICZ FRANK J 485 BELMONT ST E. BRIDGEWATER, MA 02333				83-14-04-0				485 BELMONT ST			
TRANSFER HISTORY				DOS	T	SALE PRICE	BK-PG (Cert)				
JAKOWICZ FRANK J				12/22/2003	QS	310,000	27265-325				
CENDANT MOBILITY FINANCIA				12/22/2003	N	310,000	27265-321				
MCCONNELL DANIEL E & RENA				04/30/1998	QS	154,900	16148-028				

CLASS	CLASS%	DESCRIPTION			BN ID	BN	CARD	
1010	100	SINGLE FAMILY				1	1 of 1	
PMT NO	PMT DT	TY	DESC	AMOUNT	INSP	BY	1st	%
BP-21-151 3244	04/09/2021	3	ALTERATIONS	7,150	05/11/2021	SLB	100	100
	04/27/2017	2	ADDITIONS	25,000	05/24/2017	SLB	33	100
		6	CYCL GROWTH		11/16/2016	SD	0	0
		3	ALTERATIONS				0	0
2791	12/18/2015	6	CYCL GROWTH	16,337			0	0
	08/20/2013	6	CYCL GROWTH		07/02/2013		0	0

LAND

CD	T	AC/SF/UN	Ngh	Inf1	Inf2	ADJ BASE	SAF	Inf3	Lpi	VC	CREDIT AMT	ADJ VALUE
100	S	43,560	3	1.00	100	188,000	1.00	100	1.00	3	1.00	188,000
300	A	1,150	3	1.00	100	5,700	1.00	100	1.00	ELP	1.00	6,560

TOTAL	2.150 Acres	ZONING	FRNT	0	ASSESSED	CURRENT	PREVIOUS
Ngh	RES 3	N O T E	LOT 4		LAND	194,600	177,000
Inf1	FACTOR 100		BUILDING	236,000	215,600		
Inf2	PHY 100		DETACHED	0	0		
			OTHER	0	0		
			TOTAL	430,600	392,600		

DETACHED

TY	QUAL	COND	DIM/NOTE	YB	UNITS	ADJ PRICE	RCNLD



BUILDING	CD	ADJ	DESC	MEASURE	5/11/2021	SLB
MODEL	1		RESIDENTIAL	LIST	5/11/2021	SLB
STYLE	3	1.05	SPLIT LEVEL [100%]	REVIEW	4/22/2013	ER
QUALITY	A	1.00	AVERAGE [100%]			
FRAME	1	1.00	WOOD FRAME [100%]			

BUILDING

YEAR BLT	1993	SIZE ADJ	1.000	ELEMENT	CD	DESCRIPTION	ADJ	S	BAT	T	DESCRIPTION	UNITS	YB	ADJ PRICE	RCN	TOTAL RCN	298,791
NET AREA	988	DETAIL ADJ	1.081	FOUNDATION	4	CONT BSMT WALL	1.00	+	BAS	L	BASE AREA	988	1993	239.53	236,656		
\$NLA(RCN)	\$302	OVERALL	1.000	EXT COVER	2	CLAPBOARD	1.00	B	OPA	N	OPEN PORCH	288		42.70	12,298		
				ROOF SHAPE	1	GABLE	1.00	C	EPA	N	ENCLOSED PORCH	144		74.40	10,714		
				ROOF COVER	1	ASPH SHINGLES	1.00	E	BMF	N	BSMT FINISH-SEP	456		73.20	33,379		
				FLOOR COVER	99	N/A	1.00	+	WDK	N	WOOD DECK	112		31.60	3,539		
				INT FINISH	99	N/A	1.00										
				HEATING/COOLING	9	WARM/COOL AIR	1.03										
				FUEL SOURCE	99	N/A	1.00										
				ARPUD	0		1.00										
				AFFORDABLE	0		1.00										

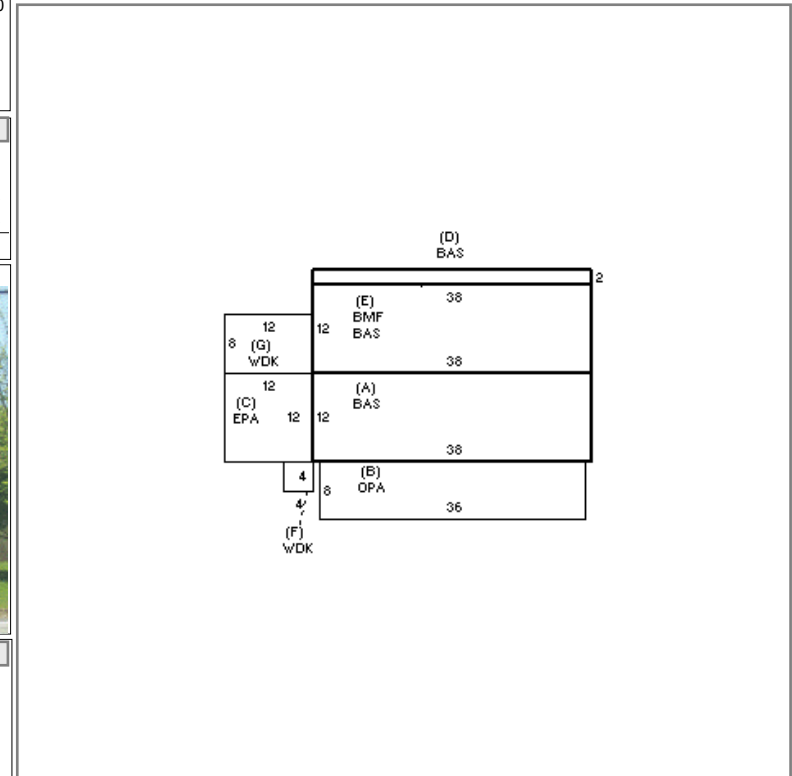

CONDITION ELEM	CD
EXTERIOR	G
INTERIOR	
KITCHEN	
BATHS	
HEAT	
ELECT	

EFF. YR/AGE	1999 / 22
COND	21 21 %
FUNC	0
ECON	0
DEPR	21 % GD 79

RCNLD	\$236,000
-------	-----------