

Key: 4915

Town of E. BRIDGEWATER - Fiscal Year 2023

12/6/2022 6:38 pm SEQ #: 4.194

LEGAL

CURRENT OWNER				PARCEL ID				LOCATION			
MACINTYRE WILLIAM & SUSAN 191 CHURCH ST E BRIDGEWATER, MA 02333				60-16-20-0				191 CHURCH ST			
TRANSFER HISTORY				DOS	T	SALE PRICE	BK-PG (Cert)				
MACINTYRE WILLIAM & SUSAN				10/24/2012	QS	380,000	42141-256				
COLES JOHN A & KATHLEEN G				03/29/1990	QS	216,000	9672-254				
ABM DEVELOPMENT INC				11/13/1989	QS		9457-197				

CLASS	CLASS%	DESCRIPTION			BN ID	BN	CARD	
1010	100	SINGLE FAMILY				1	1 of 1	
PMT NO	PMT DT	TY	DESC	AMOUNT	INSP	BY	1st	%
143		51	FIELD REVIEW		09/26/2013	LF	0	0
527	10/04/2007	6	CYCL GROWTH	23,700	06/02/2008		0	0
	04/29/2002	3	ALTERATIONS		06/02/2008		0	0
		8	POOL	1,200	07/07/2003	KB	100	100

LAND

CD	T	AC/SF/UN	Ngh	Inf1	Inf2	ADJ BASE	SAF	Inf3	Lpi	VC	CREDIT AMT	ADJ VALUE
100	S	43,560	4	1.00	100	1.00	100	1.00	4	1.20		225,600
300	A	0.360	4	1.00	100	1.00	100	1.00	ELP	1.00		2,050

TOTAL	1.360 Acres	ZONING	FRNT	0	ASSESSED	CURRENT	PREVIOUS
Ngh	RES 4	N O T E	LOT 20		LAND	227,700	190,000
Inf1	FACTOR 100		LAND	398,300	348,700		
Inf2	PHY 100		DETACHED	1,500	1,400		
			OTHER	0	0		
TOTAL						627,500	540,100

DETACHED

TY	QUAL	COND	DIM/NOTE	YB	UNITS	ADJ PRICE	RCNLD	PHOTO
SHF	A	1.00	10 0.90 8X10		80	20.44	1,500	09/27/2013

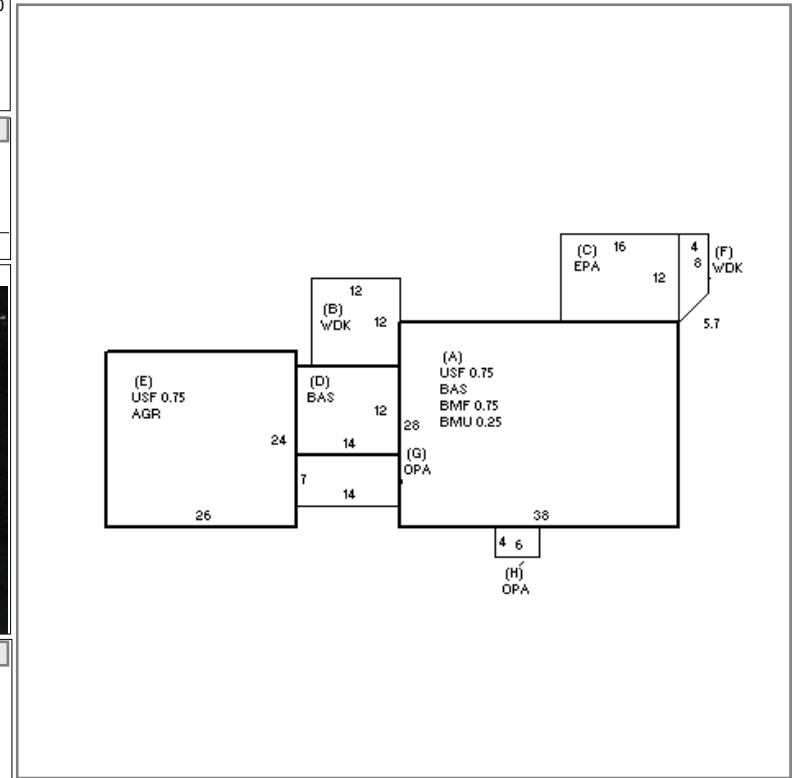

BUILDING

BUILDING	CD	ADJ	DESC	MEASURE	9/26/2013	LF
MODEL	1		RESIDENTIAL	LIST	7/7/2004	EST
STYLE	4	1.00	CAPE [100%]	REVIEW	4/22/2013	ER
QUALITY	A	1.00	AVERAGE [100%]			
FRAME	1	1.00	WOOD FRAME [100%]			

BLDG COMMENTS

LOADING

YEAR BLT	1989	SIZE ADJ	1.000	ELEMENT	CD	DESCRIPTION	ADJ	S	BAT	T	DESCRIPTION	UNITS	YB	ADJ PRICE	RCN	TOTAL RCN	517,289		
NET AREA	2,498	DETAIL ADJ	1.040	FOUNDATION	4	CONT BSMT WALL	1.00	A	BMU	N	BSMT UNFINISHED	266		38.20	10,162	CONDITION ELEM	CD		
\$NLA(RCN)	\$207	OVERALL	1.000	EXT COVER	4	VINYL	1.00	A	BMF	N	BSMT FINISH-SEP	798		53.73	42,876	EXTERIOR	G		
				ROOF SHAPE	1	GABLE	1.00	+	USF	L	UPPER STORY FIN	1,266	1989	146.52	185,497	INTERIOR			
				ROOF COVER	1	ASPH SHINGLES	1.00	+	WDK	N	WOOD DECK	184		31.60	5,814	KITCHEN			
				FLOOR COVER	1	HARDWOOD	1.00	C	EPA	N	ENCLOSED PORCH	192		74.40	14,285	BATHS			
				INT FINISH	99	N/A	1.00	+	BAS	L	BASE AREA	1,232	1989	161.24	198,647	HEAT			
				HEATING/COOLING	11	HW/COOL AIR	1.04	E	AGR	N	ATT GARAGE	624		66.69	41,615	ELECT			
				FUEL SOURCE	99	N/A	1.00	+	F21	N	OPEN PORCH	122		42.70	5,209				
				ARPUD	0		1.00			O	FPL 2S 1OP	1		6,819.00	6,819				
				AFFORDABLE	0		1.00												
																		EFF.YR/AGE	1993 / 28
																		COND	23 23 %
																		FUNC	0
																		ECON	0
																		DEPR	23 % GD 77
																		RCNLD	\$398,300