

Key: 6743

Town of E. BRIDGEWATER - Fiscal Year 2023

12/6/2022 6:38 pm SEQ #: 4.987

LEGAL

CURRENT OWNER				PARCEL ID				LOCATION				
ZEMOTEL DAVID J & GAYLE E 45 STONEGATE DR E BRIDGEWATER, MA 02333				17-5-10-0				45 STONEGATE DR				
TRANSFER HISTORY				DOS	T	SALE PRICE	BK-PG (Cert)					
ZEMOTEL DAVID J & GAYLE E				05/12/2011	QS	551,683	39923-247					
A CHAVES INC				11/09/2010	B	130,000	39242-56					
WOOD JANE W				10/15/2004	A	1	29265-196					
CD	T	AC/SF/UN	Ngh	Inf1	Inf2	ADJ BASE	SAF	Inf3	Lpi	VC	CREDIT AMT	ADJ VALUE
100	S	43,560	6	1.00	100	244,400	1.00	100	1.00	6	1.30	244,400
300	A	1,584	6	1.00	100	5,700	1.00	100	1.00	ELP	1.00	9,030

LAND

TOTAL	2.584 Acres	ZONING	FRNT	0	ASSESSED	CURRENT	PREVIOUS
Ngh	RES 6	N O T E	LOT 10 PLAN 99-789/ CONSERVATION ESMT		LAND	253,400	213,400
Inf1	FACTOR 100		BUILDING	616,300	550,100		
Inf2	PHY 100		DETACHED	0	0		
			OTHER	0	0		
			TOTAL		869,700	763,500	

TY	QUAL	COND	DIM/NOTE	YB	UNITS	ADJ PRICE	RCNLD



BLDG COMMENTS

CLASS	CLASS%	DESCRIPTION		BN ID	BN	CARD	
1010	100	SINGLE FAMILY			1	1 of 1	
PMT NO	PMT DT	TY	DESC	AMOUNT	INSP	BY	1st %
665		6	CYCL GROWTH		04/21/2020	SD	0 0
658	08/07/2012	6	CYCL GROWTH		05/17/2013	LF	0 0
	12/22/2010	6	CYCL GROWTH				0 0
	12/09/2010	3	ALTERATIONS	5,000			0 0
		1	NEW CONST	280,000			0 0

DETACHED

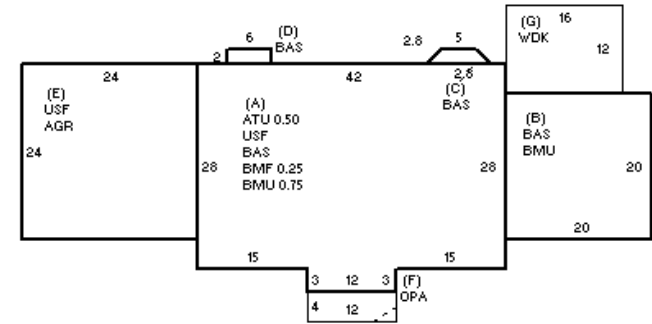

BUILDING

BUILDING	CD	ADJ	DESC	MEASURE	4/21/2020	SD
MODEL	1		RESIDENTIAL	LIST	4/21/2020	SD
STYLE	5	0.95	COLONIAL [100%]	REVIEW	5/8/2013	ER
QUALITY	G	1.15	GOOD [100%]			
FRAME	1	1.00	WOOD FRAME [100%]			

YEAR BLT	2011	SIZE ADJ	1.000	ELEMENT	CD	DESCRIPTION	ADJ	S	BAT	T	DESCRIPTION	UNITS	YB	ADJ PRICE	RCN	TOTAL RCN	684,783		
NET AREA	3,426	DETAIL ADJ	0.978	FOUNDATION	4	CONT BSMT WALL	1.00	+	BMU	N	BSMT UNFINISHED	1,309		39.87	52,184	CONDITION ELEM	CD		
\$NLA(RCN)	\$200	OVERALL	1.000	EXT COVER	2	CLAPBOARD	1.00	A	BMF	N	BSMT FINISH-SEP	303		56.07	16,988	EXTERIOR			
				ROOF SHAPE	1	GABLE	1.00	+	USF	L	UPPER STORY FIN	1,788	2011	146.35	261,672	INTERIOR			
				ROOF COVER	1	ASPH SHINGLES	1.00	A	ATU	N	ATTIC UNF	606		34.85	21,116	KITCHEN			
				FLOOR COVER	1	HARDWOOD	1.00	+	BAS	L	BASE AREA	1,638	2011	161.05	263,797	BATHS			
				INT FINISH	2	DRYWALL	1.00	E	AGR	N	ATT GARAGE	576		78.07	44,966	HEAT			
				HEATING/COOLING	9	WARM/COOL AIR	1.03	F	OPA	N	OPEN PORCH	48		49.11	2,358	ELECT			
				FUEL SOURCE	99	N/A	1.00	G	WDK	N	WOOD DECK	192		36.34	6,977				
				ARPUD	0		1.00		F21	O	FPL 2S 1OP	1		7,841.90	7,842				
				AFFORDABLE	0		1.00												
CAPACITY		UNITS	ADJ															EFF.YR/AGE	2011 / 10
STORIES		2.5	1.00															COND	10 10 %
ROOMS		7	1.00															FUNC	0
BEDROOMS		4	1.00															ECON	0
BATHROOMS		2	1.00															DEPR	10 % GD 90
# 1/2 BATHS		1	1.00															RCNLD	\$616,300
TOT FIXTURES		9	\$6,883																
# UNITS		1	1.00																