

Key: 676

Town of E. BRIDGEWATER - Fiscal Year 2023

12/6/2022 6:38 pm SEQ #: 584

LEGALS

CURRENT OWNER				PARCEL ID				LOCATION			
NEE JAMES P & JENNIFER A 268 EAST ST E BRIDGEWATER, MA 02333				12-9-0				268 EAST ST			
TRANSFER HISTORY				DOS	T	SALE PRICE		BK-PG (Cert)			
NEE JAMES P & JENNIFER A				10/24/2007	A	1 35215-299		1 20156-231			
NEE JAMES P				07/09/2001	A	1 20156-231		1 12904-043			
NEE EILEEN & NEE JAMES P				05/25/1994	A	1 12904-043					

CLASS	CLASS%	DESCRIPTION		BN ID	BN	CARD	
1010	100	SINGLE FAMILY			1	1 of 1	
PMT NO	PMT DT	TY	DESC	AMOUNT	INSP	BY	1st %
BP-20-363	07/27/2020	6	CYCL GROWTH		03/15/2022	SD	0 0
3311	06/15/2017	2	ADDITIONS	9,000	04/01/2021	SD	33 100
3107	11/07/2016	8	POOL	4,500	03/12/2021	SLB	100 100
		2	ADDITIONS	2,500	03/30/2017	SLB	100 100
		51	FIELD REVIEW		10/16/2013	SLB	0 0

LAND

CD	T	AC/SF/UN	Ngh	Inf1	Inf2	ADJ BASE	SAF	Inf3	Lpi	VC	CREDIT AMT	ADJ VALUE
100	S	43,560 3	1.00	100	1.00	188,000	1.00	100	1.00	3	1.00	188,000
300	A	1,500 3	1.00	100	1.00	5,700	1.00	100	1.00	ELP	1.00	8,550

DETACHED

TOTAL	2.500 Acres		ZONING	FRNT	0	ASSESSED	CURRENT	PREVIOUS
Ngh	RES 3		NOTE			LAND	196,600	178,800
Inf1	FACTOR 100					BUILDING	247,800	185,000
Inf2	PHY 100					DETACHED	2,500	2,300
						OTHER	0	0
						<b>TOTAL</b>	<b>446,900</b>	<b>366,100</b>

BUILDING

TY	QUAL	COND	DIM/NOTE	YB	UNITS	ADJ PRICE	RCNLD
SHF	A	1.00 40 0.60			200	20.44	2,500
SHF	A	1.00 NV 0.00	16 X 10		160	20.44	

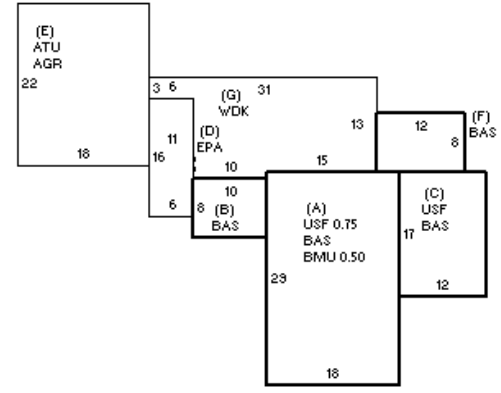

BLDG COMMENTS

BUILDING	CD	ADJ	DESC	MEASURE	3/11/2022	SD
MODEL	1		RESIDENTIAL	LIST	3/11/2022	SD
STYLE	7	0.90	CONVENTIONAL [100%]	REVIEW	3/19/2013	ER
QUALITY	A	1.00	AVERAGE [100%]			
FRAME	1	1.00	WOOD FRAME [100%]			

YEAR BLT	1900	SIZE ADJ	1.000	ELEMENT	CD	DESCRIPTION	ADJ	S	BAT	T	DESCRIPTION	UNITS	YB	ADJ PRICE	RCN	TOTAL RCN	321,812
NET AREA	1,498	DETAIL ADJ	0.927	FOUNDATION	4	CONT BSMT WALL	1.00	A	BMU	N	BSMT UNFINISHED	261		52.05	13,585		
\$NLA(RCN)	\$215	OVERALL	1.000	EXT COVER	4	VINYL	1.00	A	USF	L	UPPER STORY FIN	392	1900	155.11	60,803		
				ROOF SHAPE	1	GABLE	1.00	+	BAS	L	BASE AREA	902	1900	170.69	153,961		
				ROOF COVER	1	ASP SHINGLES	1.00	C	USF	L	UPPER STORY FIN	204	2021	155.11	31,642		
				FLOOR COVER	99	N/A	1.00	D	EPA	N	ENCLOSED PORCH	96		74.40	7,142		
				INT FINISH	99	N/A	1.00	E	AGR	N	ATT GARAGE	396		74.83	29,634		
				HEATING/COOLING	9	WARM/COOL AIR	1.03	E	ATU	N	ATTIC UNF	396		30.30	11,999		
				FUEL SOURCE	99	N/A	1.00	G	WDK	N	WOOD DECK	353		31.60	11,155		
				ARPUD	0		1.00										
				AFFORDABLE	0		1.00										

CONDITION ELEM	CD
EXTERIOR	
INTERIOR	
KITCHEN	
BATHS	
HEAT	U
ELECT	U

EFF. YR/AGE	1993 / 28	
COND	23	23 %
FUNC	0	
ECON	0	
DEPR	23	% GD 77
RCNLD	\$247,800	