

Key: 7134

Town of E. BRIDGEWATER - Fiscal Year 2023

12/6/2022 6:38 pm SEQ #: 5.237

LEGAL

CURRENT OWNER				PARCEL ID				LOCATION				
KEARNEY JOAN A 40 RODEO DR E BRIDGEWATER, MA 02333				81-34-75-0				40 RODEO DR				
TRANSFER HISTORY				DOS	T	SALE PRICE	BK-PG (Cert)					
KEARNEY JOAN A				03/21/2018	A	100	49608-348					
KEARNEY WILLIAM R & JOAN				08/27/2008	A	1	36306-026					
KEARNEY WILLIAM R & JOAN				10/22/2004	QS	253,220	29306-339					
CD	T	AC/SF/UN	Ngh	Infl1	Infl2	ADJ BASE	SAF	Infl3	Lpi	VC	CREDIT AMT	ADJ VALUE
100	S	8,203 1	1.00	100	1.00	122,200	4.45	100	1.00	8	0.65	102,360

LAND

TOTAL	8,203 SF	ZONING	FRNT	0	ASSESSED	CURRENT	PREVIOUS
Ngh	RES 1	NOTE			LAND	102,400	93,100
Infl1	FACTOR 100				BUILDING	240,600	224,100
Infl2	PHY 100				DETACHED	0	0
					OTHER	0	0
					TOTAL	343,000	317,200

DETACHED

TY	QUAL	COND	DIM/NOTE	YB	UNITS	ADJ PRICE	RCNLD	PHOTO
								09/14/2021



BUILDING

BUILDING	CD	ADJ	DESC	MEASURE	9/10/2021	SD
MODEL	1		RESIDENTIAL	LIST	9/10/2021	SD
STYLE	1	1.00	RANCH [100%]	REVIEW	5/10/2013	ER
QUALITY	A	1.00	AVERAGE [100%]			
FRAME	1	1.00	WOOD FRAME [100%]			

INDING

YEAR BLT	2004	SIZE ADJ	1.000	ELEMENT	CD	DESCRIPTION	ADJ	S	BAT	T	DESCRIPTION	UNITS	YB	ADJ PRICE	RCN	TOTAL RCN	289,835
NET AREA	1,056	DETAIL ADJ	1.030	FOUNDATION	4	CONT BSMT WALL	1.00	A	BMU	N	BSMT UNFINISHED	1,040		38.45	39,986		
\$NLA(RCN)	\$274	OVERALL	1.000	EXT COVER	4	VINYL	1.00	B	EPA	N	ENCLOSED PORCH	104		74.40	7,738		
				ROOF SHAPE	1	GABLE	1.00	+	BAS	L	BASE AREA	1,056	2004	220.87	233,242		
				ROOF COVER	1	ASPH SHINGLES	1.00	E	PTA	N	PATIO	308		12.50	3,850		
				FLOOR COVER	99	N/A	1.00	+	WDK	N	WOOD DECK	48		31.60	1,517		
				INT FINISH	99	N/A	1.00										
				HEATING/COOLING	9	WARM/COOL AIR	1.03										
				FUEL SOURCE	99	N/A	1.00										
				ARPUD	0		1.00										
				AFFORDABLE	0		1.00										

CLASS	CLASS%	DESCRIPTION			BN ID	BN	CARD	
1010	100	SINGLE FAMILY			1	1	of 1	
PMT NO	PMT DT	TY	DESC	AMOUNT	INSP	BY	1st	%
682	08/06/2013	6	CYCL GROWTH		09/10/2021	SD	0	0
	07/27/2004	6	CYCL GROWTH	110,000	07/01/2013	SLB	0	0
		1	NEW CONST		11/22/2004	SLB	100	100

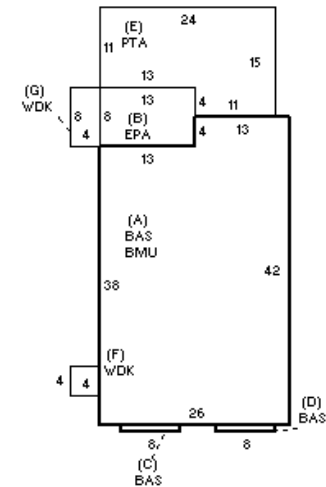

BLDG COMMENTS

CONDITION ELEM	CD
EXTERIOR	
INTERIOR	
KITCHEN	
BATHS	
HEAT	
ELECT	
EFF.YR/AGE 2004 / 17	
COND	17 17 %
FUNC	0
ECON	0
DEPR	17 % GD 83
RCNLD	\$240,600