

Key: 7335

Town of E. BRIDGEWATER - Fiscal Year 2023

12/6/2022 6:38 pm SEQ #: 5.398

LEGALS

CURRENT OWNER				PARCEL ID				LOCATION			
MCLAUGHLIN ANN S/O CRAWFORD STEPHEN P 6 HARMONY CROSSING E BRIDGEWATER, MA 02333				81-34-19-0				6 HARMONY CROSSING			
TRANSFER HISTORY				DOS	T	SALE PRICE	BK-PG (Cert)				
CRAWFORD STEPHEN P				04/20/2022	QS	413,000	56708-233				
MCLAUGHLIN ANN				09/12/2012	QS	273,000	41936-009				
BROWN BUILDERS INC				06/04/2007	F	1,356,000	34624-158				

CLASS	CLASS%	DESCRIPTION			BN ID	BN	CARD	
1010	100	SINGLE FAMILY				1	1 of 1	
PMT NO	PMT DT	TY	DESC	AMOUNT	INSP	BY	1st	%
2266	11/07/2014	6	CYCL GROWTH		09/27/2022	SD	0	0
		99	OTHER		09/08/2021	SD	0	0
		3	ALTERATIONS				0	0
		51	FIELD REVIEW		09/26/2013	PW	0	0
1226	07/06/2012	3	ALTERATIONS	13,800			0	0

LAND

CD	T	AC/SF/UN	Ngh	Inf1	Inf2	ADJ BASE	SAF	Inf3	Lpi	VC	CREDIT AMT	ADJ VALUE					
100	S	15,800	1	1.00	100	1.00	100	1.00	122,200	2.41	100	1.00	8	0.65			106,630

TOTAL	15,800 SF	ZONING	FRNT	0	ASSESSED	CURRENT	PREVIOUS
Ngh	RES 1	NOTE			LAND	106,600	97,000
Inf1	FACTOR 100		BUILDING	283,000	261,700		
Inf2	PHY 100		DETACHED	0	0		
			OTHER	0	0		
					TOTAL	389,600	358,700

DETACHED

TY	QUAL	COND	DIM/NOTE	YB	UNITS	ADJ PRICE	RCNLD

PHOTO 09/28/2022



BLDG COMMENTS		
upgrades		

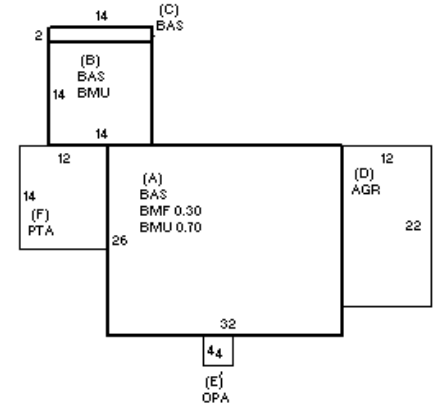

BUILDING

BUILDING	CD	ADJ	DESC	MEASURE	9/27/2022	SD
MODEL	1		RESIDENTIAL	LIST	9/27/2022	SD
STYLE	1	1.00	RANCH [100%]	REVIEW	5/13/2013	ER
QUALITY	A	1.00	AVERAGE [100%]			
FRAME	1	1.00	WOOD FRAME [100%]			

YEAR BLT	2012	SIZE ADJ	1.000	ELEMENT	CD	DESCRIPTION	ADJ	S	BAT	T	DESCRIPTION	UNITS	YB	ADJ PRICE	RCN	TOTAL RCN	311,024
NET AREA	1,056	DETAIL ADJ	1.030	FOUNDATION	4	CONT BSMT WALL	1.00	+	BMU	N	BSMT UNFINISHED	778		38.55	29,993		
\$NLA(RCN)	\$295	OVERALL	1.000	EXT COVER	4	VINYL	1.00	A	BMF	N	BSMT FINISH-SEP	250		54.22	13,554		
				ROOF SHAPE	1	GABLE	1.00	+	BAS	L	BASE AREA	1,056	2012	220.87	233,242		
				ROOF COVER	1	ASPH SHINGLES	1.00	D	AGR	N	ATT GARAGE	264		85.86	22,666		
				FLOOR COVER	13	COMB	1.00	E	OPA	N	OPEN PORCH	16		42.69	683		
				INT FINISH	2	DRYWALL	1.00	F	PTA	N	PATIO	168		12.50	2,100		
				HEATING/COOLING	9	WARM/COOL AIR	1.03		GFP	O	GAS FIREPLACE	1		4,584.00	4,584		
				FUEL SOURCE	2	GAS	1.00										
				ARPUD	0		1.00										
				AFFORDABLE	0		1.00										

CONDITION ELEM	CD
EXTERIOR	
INTERIOR	
KITCHEN	
BATHS	
HEAT	
ELECT	

EFF.YR/AGE	2012 / 9
COND	9 9 %
FUNC	0
ECON	0
DEPR	9 % GD 91
RCNLD	\$283,000