

Key: 760

Town of E. BRIDGEWATER - Fiscal Year 2023

12/6/2022 6:38 pm SEQ #: 650

LEGAL

CURRENT OWNER				PARCEL ID				LOCATION			
BROWN JON S & NICOLE 2020 WASHINGTON ST E BRIDGEWATER, MA 02333				17-14-0				2020 WASHINGTON ST			
TRANSFER HISTORY				DOS	T	SALE PRICE	BK-PG (Cert)				
BROWN JON S & NICOLE				12/17/2007	A	1 35407-062					
BROWN JON S				12/17/2007	A	1 35407-060					
BROWN JON S &				10/29/2004	QS	338,000 29372-002					

CLASS	CLASS%	DESCRIPTION		BN ID	BN	CARD	
1010	100	SINGLE FAMILY			1	1 of 1	
PMT NO	PMT DT	TY	DESC	AMOUNT	INSP	BY	1st %
BP-20-551	11/06/2020	6	CYCL GROWTH	43,000	03/02/2021	SD	0 0
		3	ALTERATIONS				0 0
		99	OTHER		09/29/2020	SD	0 0
		6	CYCL GROWTH		04/22/2014	LF	0 0
6	01/13/2009	7	DETACHED BLD	28,000	05/19/2009		0 0

LAND

CD	T	AC/SF/UN	Ngh	Inf1	Inf2	ADJ BASE	SAF	Inf3	Lpi	VC	CREDIT AMT	ADJ VALUE
100	S	40,711 3	1.00	100	1.00	188,000	1.06	100	1.00	3	1.00	185,540

TOTAL	40,711 SF	ZONING	FRNT	0	ASSESSED	CURRENT	PREVIOUS
Ngh	RES 3	NOTE PLAN 10-328 - INCL PARCEL B	LAND	185,500	168,800		
Inf1	FACTOR 100		BUILDING	283,900	244,000		
Inf2	PHY 100		DETACHED	46,000	43,700		
			OTHER	0	0		
			TOTAL	515,400	456,500		

DETACHED

TY	QUAL	COND	DIM/NOTE	YB	UNITS	ADJ PRICE	RCNLD
SHF	A	1.00	40 0.60		200	20.44	2,500
IPV	A	1.00	10 0.90	2009	648	19.48	11,400
GFU	A	1.00	10 0.90 24X24	2009	576	62.00	32,100

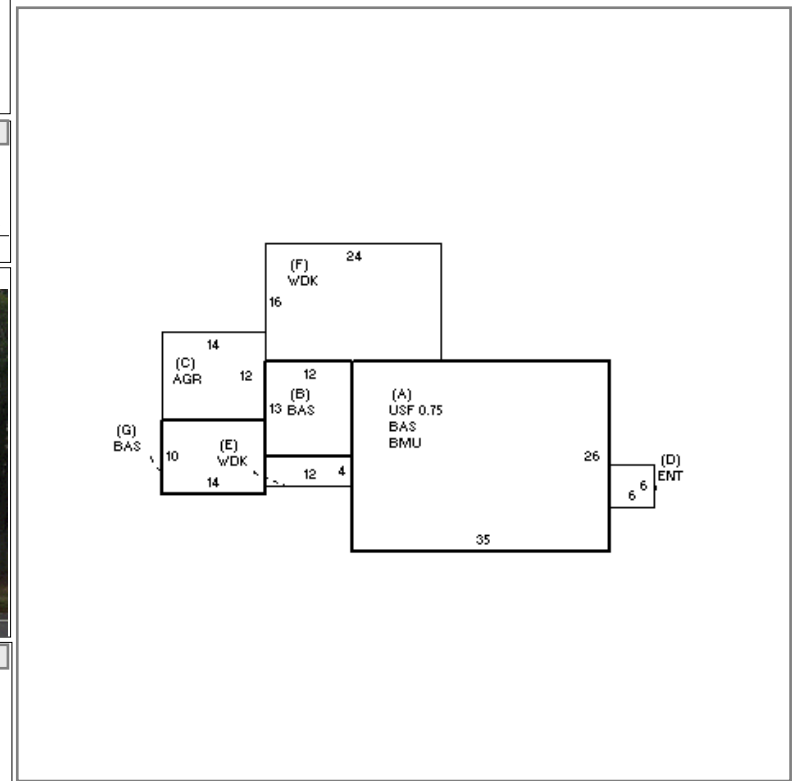

BUILDING

BUILDING	CD	ADJ	DESC	MEASURE	3/2/2021	SD
MODEL	1		RESIDENTIAL	LIST	3/2/2021	SD
STYLE	4	1.00	CAPE [100%]	REVIEW	3/20/2013	ER
QUALITY	A	1.00	AVERAGE [100%]			
FRAME	1	1.00	WOOD FRAME [100%]			

BLDG COMMENTS

G

YEAR BLT	1960	SIZE ADJ	1.000	ELEMENT	CD	DESCRIPTION	ADJ	S	BAT	T	DESCRIPTION	UNITS	YB	ADJ PRICE	RCN	TOTAL RCN	388,867
NET AREA	1,889	DETAIL ADJ	1.020	FOUNDATION	4	CONT BSMT WALL	1.00	A	BMU	N	BSMT UNFINISHED	910		39.97	36,377		
\$NLA(RCN)	\$206	OVERALL	1.000	EXT COVER	4	VINYL	1.00	A	USF	L	UPPER STORY FIN	683	1960	156.62	106,973		
				ROOF SHAPE	1	GABLE	1.00	+	BAS	L	BASE AREA	1,206	1960	172.35	207,858		
				ROOF COVER	1	ASPH SHINGLES	1.00	C	AGR	N	ATT GARAGE	168		104.88	17,620		
				FLOOR COVER	99	N/A	1.00	D	ENT	N	ENCLOSED ENTRY	36		81.11	2,920		
				INT FINISH	99	N/A	1.00	+	WDK	N	WOOD DECK	432		31.60	13,651		
				HEATING/COOLING	2	HOT WATER	1.02										
				FUEL SOURCE	99	N/A	1.00										
				ARPUD	0		1.00										
				AFFORDABLE	0		1.00										
																CONDITION ELEM	CD
																EXTERIOR	
																INTERIOR	
																KITCHEN	
																BATHS	
																HEAT	
																ELECT	
																EFF.YR/AGE	1980 / 41
																COND	27 27 %
																FUNC	0
																ECON	0
																DEPR	27 % GD 73
																RCNLD	\$283,900