

Key: 801

Town of E. BRIDGEWATER - Fiscal Year 2023

12/6/2022 6:38 pm SEQ #: 689

LEGALS

CURRENT OWNER				PARCEL ID				LOCATION				
WOLFTHAL SUSAN F & DAVID M 15 SANDRA DR E. BRIDGEWATER, MA 02333				17-55-0				15 SANDRA DR				
TRANSFER HISTORY				DOS	T	SALE PRICE	BK-PG (Cert)					
WOLFTHAL SUSAN F & DAVID				09/12/2001	1	344,907	20523-002					
FITZGERALD GLENN A & KIM				06/05/1998	QS	218,000	16268-161					
GRAZIANO JOHN B &				07/29/1994	D	199,775	13055-057					
CD	T	AC/SF/UN	Ngh	Inf1	Inf2	ADJ BASE	SAF	Inf3	Lpi	VC	CREDIT AMT	ADJ VALUE
100	S	35,000 4	1.00	100	1.00	225,600	1.20	100	1.00	4	1.20	216,740

CLASS	CLASS%	DESCRIPTION		BN ID	BN	CARD	
1010	100	SINGLE FAMILY			1	1 of 1	
PMT NO	PMT DT	TY	DESC	AMOUNT	INSP	BY	1st %
734	02/21/2012	51	FIELD REVIEW		12/15/2014	LF	0 0
	10/10/2006	6	CYCL GROWTH		02/21/2012		0 0
		2	ADDITIONS	45,000			0 0

LAND

TOTAL	35,000 SF	ZONING	FRNT	0	ASSESSED	CURRENT	PREVIOUS
Ngh	RES 4	N O T E	LOT 14		LAND	216,700	180,700
Inf1	FACTOR 100		BUILDING	395,800	353,900		
Inf2	PHY 100		DETACHED	0	0		
			OTHER	0	0		
			<b>TOTAL</b>	<b>612,500</b>	<b>534,600</b>		

DETACHED

TY	QUAL	COND	DIM/NOTE	YB	UNITS	ADJ PRICE	RCNLD

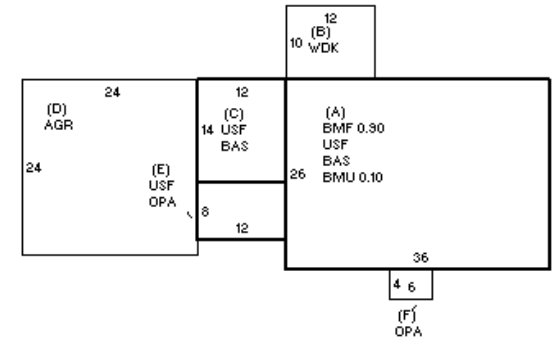
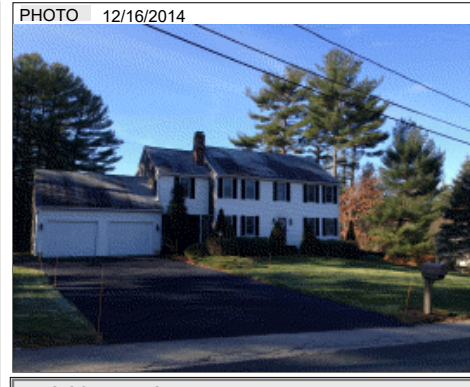

BUILDING

BUILDING	CD	ADJ	DESC	MEASURE	12/15/2014	LF
MODEL	1		RESIDENTIAL	LIST		
STYLE	5	0.95	COLONIAL [100%]	REVIEW	3/20/2013	ER
QUALITY	+	1.05	AVG +/GOOD - [100%]			
FRAME	1	1.00	WOOD FRAME [100%]			

BLDG COMMENTS

LINDING

YEAR BLT	2006	SIZE ADJ	1.000	ELEMENT	CD	DESCRIPTION	ADJ	S	BAT	T	DESCRIPTION	UNITS	YB	ADJ PRICE	RCN	TOTAL RCN	465.605
NET AREA	2,304	DETAIL ADJ	0.950	FOUNDATION	4	CONT BSMT WALL	1.00	A	BMU	N	BSMT UNFINISHED	94		41.61	3,911		
\$NLA(RCN)	\$202	OVERALL	1.000	EXT COVER	2	CLAPBOARD	1.00	+	USF	L	UPPER STORY FIN	1,200	2006	143.85	172,621		
				ROOF SHAPE	1	GABLE	1.00	A	BMF	N	BSMT FINISH-SEP	842		58.52	49,270		
				ROOF COVER	1	ASPH SHINGLES	1.00	B	WDK	N	WOOD DECK	120		33.18	3,982		
				FLOOR COVER	99	N/A	1.00	+	BAS	L	BASE AREA	1,104	2006	158.30	174,763		
				INT FINISH	99	N/A	1.00	D	AGR	N	ATT GARAGE	576		71.28	41,056		
				HEATING/COOLING	1	FORCED AIR	1.00	+	OPA	N	OPEN PORCH	120		44.84	5,380		
				FUEL SOURCE	99	N/A	1.00	F21	O	O	FPL 2S 1OP	1		7,160.00	7,160		
				ARPUD	0		1.00										
				AFFORDABLE	0		1.00										
																CONDITION ELEM	CD
																EXTERIOR	
																INTERIOR	
																KITCHEN	
																BATHS	
																HEAT	
																ELECT	
																EFF.YR/AGE	2006 / 15
																COND	15 15%
																FUNC	0
																ECON	0
																DEPR	15 % GD 85
																RCNLD	\$395,800