

Key: 880

Town of E. BRIDGEWATER - Fiscal Year 2023

12/6/2022 6:38 pm SEQ #: 736

LEGAL

CURRENT OWNER				PARCEL ID				LOCATION			
JOHNSON SUSAN H 805 PLYMOUTH ST E BRIDGEWATER, MA 02333				19-17-0				805 PLYMOUTH ST			
TRANSFER HISTORY				DOS	T	SALE PRICE	BK-PG (Cert)				
JOHNSON SUSAN H				06/16/1986	QS	6854-255	6854-255				
JOHNSON LEWIS A JR & SUSA				07/17/1981	QS	5026-046	5026-046				
ZILINSKY MILDRED C				04/20/1979	QS	4715-301	4715-301				

CLASS	CLASS%	DESCRIPTION			BN ID	BN	CARD	
1010	100	SINGLE FAMILY				1	1 of 1	
PMT NO	PMT DT	TY	DESC	AMOUNT	INSP	BY	1st	%
BP-18-56	05/26/2018	3	ALTERATIONS	26,114	05/01/2019	SLB	100	100
BP-18-48	05/22/2018	3	ALTERATIONS	15,000	05/01/2019	SLB	100	100
		51	FIELD REVIEW		08/25/2013	LF	0	0

LAND

CD	T	AC/SF/UN	Ngh	Infl1	Infl2	ADJ BASE	SAF	Infl3	Lpi	VC	CREDIT AMT	ADJ VALUE
100	S	25,000	7	1.00	100	1.00	100	1.00	7	0.95		163,380

TOTAL	25,000 SF	ZONING	FRNT	0	ASSESSED	CURRENT	PREVIOUS
Ngh	RES 7	N T 14450 O T E			LAND	163,400	148,600
Infl1	FACTOR 100		BUILDING	209,200	191,400		
Infl2	PHY 100		DETACHED	0	0		
			OTHER	0	0		
<b>TOTAL</b>						<b>372,600</b>	<b>340,000</b>

DETACHED

TY	QUAL	COND	DIM/NOTE	YB	UNITS	ADJ PRICE	RCNLD	PHOTO
								09/24/2013



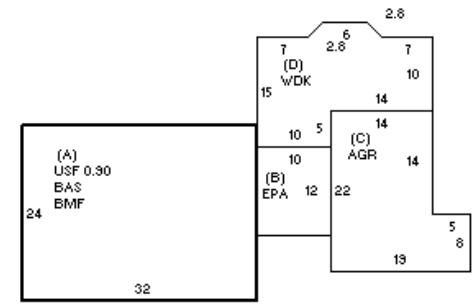

BUILDING

BUILDING	CD	ADJ	DESC	MEASURE	8/25/2013	LF
MODEL	1		RESIDENTIAL	LIST		
STYLE	5	0.95	COLONIAL [100%]	REVIEW	3/21/2013	ER
QUALITY	A	1.00	AVERAGE [100%]			
FRAME	1	1.00	WOOD FRAME [100%]			

YEAR BLT	1965	SIZE ADJ	1.000	ELEMENT	CD	DESCRIPTION	ADJ	S	BAT	T	DESCRIPTION	UNITS	YB	ADJ PRICE	RCN	TOTAL RCN	348,717
NET AREA	1,459	DETAIL ADJ	0.950	FOUNDATION	4	CONT BSMT WALL	1.00	A	BMF	N	BSMT FINISH-SEP	768		59.39	45,611		
\$NLA(RCN)	\$239	OVERALL	1.000	EXT COVER	1	WD SHINGLES	1.00	A	BAS	L	BASE AREA	768	1965	176.74	135,739		
				ROOF SHAPE	3	GAMBREL	1.00	A	USF	L	UPPER STORY FIN	691	1965	160.61	110,982		
				ROOF COVER	1	ASPH SHINGLES	1.00	B	EPA	N	ENCLOSED PORCH	120		74.40	8,928		
				FLOOR COVER	99	N/A	1.00	C	AGR	N	ATT GARAGE	348		77.85	27,092		
				INT FINISH	99	N/A	1.00	D	WDK	N	WOOD DECK	306		31.60	9,670		
				HEATING/COOLING	1	FORCED AIR	1.00	F21	O	O	FPL 2S 1OP	1		6,819.00	6,819		
				FUEL SOURCE	99	N/A	1.00										
				ARPUD	0		1.00										
				AFFORDABLE	0		1.00										

CONDITION ELEM	CD
EXTERIOR	
INTERIOR	
KITCHEN	
BATHS	
HEAT	
ELECT	
<b>TOTAL RCN</b> 348,717	
EFF.YR/AGE	1965 / 56
COND	40 40 %
FUNC	0
ECON	0
DEPR	40 % GD 60
RCNLD	\$209,200