

Key: 952

Town of E. BRIDGEWATER - Fiscal Year 2023

12/6/2022 6:38 pm SEQ #: 804

LEGALS

CURRENT OWNER				PARCEL ID				LOCATION				
EAST STREET REALTY TRUST LAMBERT SCOTT A & GINA R TRS 74 EAST ST E BRIDGEWATER, MA 02333				21-17-0				74 EAST ST				
TRANSFER HISTORY				DOS	T	SALE PRICE		BK-PG (Cert)				
EAST STREET REALTY TRUST				01/11/2016	A	1 46478-117						
LAMBERT SCOTT A SR, PAUL				02/22/2007	A	1 34145-302						
LAMBERT SCOTT				12/29/2006	N	470,000 33912-162						
CD	T	AC/SF/UN	Ngh	Inf1	Inf2	ADJ BASE	SAF	Inf3	Lpi	VC	CREDIT AMT	ADJ VALUE
100	S	35,000 3	1.00	100	1.00	188,000	1.20	100	3	1.00		180,620
300	A	3,750 3	1.00	100	1.00	4,560	1.00	80	0.80	ELP	1.00	17,100

LAND

TOTAL	4.553 Acres	ZONING	FRNT	0	ASSESSED	CURRENT	PREVIOUS
Ngh	RES 3	N O T E c/w 21/18			LAND	197,700	179,900
Inf1	FACTOR 100		BUILDING	335,400	287,700		
Inf2	PHY 100		DETACHED	39,100	37,200		
			OTHER	0	0		
					TOTAL	572,200	504,800

DETAILED

TY	QUAL	COND	DIM/NOTE	YB	UNITS	ADJ PRICE	RCNLD	PHOTO	04/10/2017
DG2	A	1.00 10 0.90			552	62.53	31,100		
IPF	A	1.00 10 0.90	13 X 25	2016	325	27.42	8,000		

BUILDING

BUILDING	CD	ADJ	DESC	MEASURE	4/17/2017	SLB
MODEL	1		RESIDENTIAL	LIST		
STYLE	4	1.00	CAPE [100%]	REVIEW	3/21/2013	ER
QUALITY	A	1.00	AVERAGE [100%]			
FRAME	1	1.00	WOOD FRAME [100%]			

YEAR BLT	1953	SIZE ADJ	1.000	ELEMENT	CD	DESCRIPTION	ADJ	S	BAT	T	DESCRIPTION	UNITS	YB	ADJ PRICE	RCN	TOTAL RCN	441,270
NET AREA	2,431	DETAIL ADJ	1.000	FOUNDATION	4	CONT BSMT WALL	1.00	+	BMU	N	BSMT UNFINISHED	990		36.82	36,449		
\$NLA(RCN)	\$182	OVERALL	1.000	EXT COVER	1	WD SHINGLES	1.00	A	BMF	N	BSMT FINISH-SEP	234		51.78	12,116		
				ROOF SHAPE	1	GABLE	1.00	A	USF	L	UPPER STORY FIN	702	1953	142.00	99,681		
				ROOF COVER	1	ASPH SHINGLES	1.00	+	BAS	L	BASE AREA	1,729	1953	156.26	270,169		
				FLOOR COVER	99	N/A	1.00	+	OPA	N	OPEN PORCH	280		42.70	11,956		
				INT FINISH	99	N/A	1.00	F21	O	FPL 2S 1OP	1		6,819.00	6,819			
				HEATING/COOLING	1	FORCED AIR	1.00										
				FUEL SOURCE	99	N/A	1.00										
				ARPUD	0		1.00										
				AFFORDABLE	0		1.00										

CLASS	CLASS%	DESCRIPTION		BN ID	BN	CARD		
1010	100	SINGLE FAMILY			1	1 of 1		
PMT NO	PMT DT	TY	DESC	AMOUNT	INSP	BY	1st	%
BP-19-72	03/08/2019	3	ALTERATIONS	740				0 0
BP-18-308	10/30/2018	3	ALTERATIONS	3,195				0 0
3003	07/21/2016	8	POOL	30,000	04/17/2017	SLB	100	100
2128	07/28/2014	3	ALTERATIONS	17,000	12/22/2014	SLB	100	100
		51	FIELD REVIEW		10/16/2013	SLB	0	0

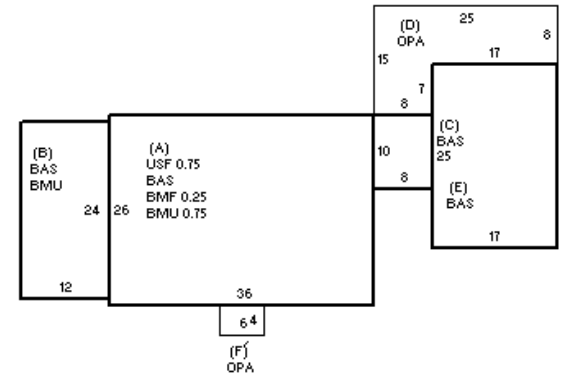

BLDG COMMENTS

CONDITION ELEM	CD
EXTERIOR	
INTERIOR	
KITCHEN	
BATHS	
HEAT	
ELECT	
EFF.YR/AGE 1990 / 31	
COND	24 24 %
FUNC	0
ECON	0
DEPR	24 % GD 76
RCNLD	\$335,400