

Key: 994

Town of E. BRIDGEWATER - Fiscal Year 2023

12/6/2022 6:38 pm SEQ #: 832

LEG  
A  
L  
L  
A  
N  
D

CURRENT OWNER				PARCEL ID				LOCATION				
BEDDIA TIMOTHY S 770 BEDFORD ST E BRIDGEWATER, MA 02333				22-12-0 770 BEDFORD ST								
TRANSFER HISTORY				DOS	T	SALE PRICE	BK-PG (Cert)					
BEDDIA TIMOTHY S				11/25/2020	A	385,000	(131159)					
BEDDIA DIANE F TRUSTEE				05/09/2012	A	1	(117410)					
BEDDIA DIANE F				01/30/1998	QS	130,000	(92796)					
CD	T	AC/SF/UN	Ngh	Inf1	Inf2	ADJ BASE	SAF	Inf3	Lpi	VC	CREDIT AMT	ADJ VALUE
100	S	11,325 7	1.00	100	1.00	178,600	3.28	100	1.00	7	0.95	152,170

CLASS	CLASS%	DESCRIPTION			BN ID	BN	CARD	
1040	100	TWO FAMILY				1	1 of 1	
PMT NO	PMT DT	TY	DESC	AMOUNT	INSP	BY	1st	%
1105	02/27/2012	99	OTHER		07/09/2014	LF	0	0
		6	CYCL GROWTH		03/07/2013	PW	0	0
		3	ALTERATIONS	1,800	04/09/2012		100	100

D  
E  
T  
A  
C  
H  
E  
D

TOTAL	11,325 SF	ZONING	FRNT	0	ASSESSED	CURRENT	PREVIOUS
Ngh	RES 7	NOTE #421623 #92796.	LAND		152,200	138,400	
Inf1	FACTOR 100		BUILDING		116,400	116,200	
Inf2	PHY 100		DETACHED		0	0	
			OTHER		0	0	
			TOTAL		268,600	254,600	

TY	QUAL	COND	DIM/NOTE	YB	UNITS	ADJ PRICE	RCNLD

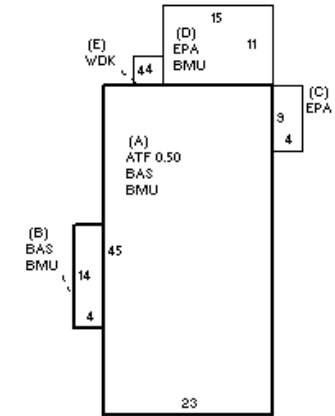

B  
U  
I  
L  
D  
I  
N  
G

BUILDING	CD	ADJ	DESC	MEASURE	7/9/2014	LF
MODEL	1		RESIDENTIAL	LIST	7/9/2014	LF
STYLE	7	0.90	CONVENTIONAL [100%]	REVIEW	3/22/2013	ER
QUALITY	A	1.00	AVERAGE [100%]			
FRAME	1	1.00	WOOD FRAME [100%]			

BLDG COMMENTS

YEAR BLT	1865	SIZE ADJ	1.000	ELEMENT	CD	DESCRIPTION	ADJ	S	BAT	T	DESCRIPTION	UNITS	YB	ADJ PRICE	RCN	TOTAL RCN	323,242
NET AREA	1,609	DETAIL ADJ	1.009	FOUNDATION	4	CONT BSMT WALL	1.00	+	BMU	N	BSMT UNFINISHED	1,256		36.61	45,980		
\$NLA(RCN)	\$201	OVERALL	1.000	EXT COVER	4	VINYL	1.00	+	BAS	L	BASE AREA	1,091	1865	180.69	197,132		
				ROOF SHAPE	1	GABLE	1.00	A	ATF	L	ATTIC FINISH	518	1865	116.90	60,553		
				ROOF COVER	1	ASPH SHINGLES	1.00	+	EPA	N	ENCLOSED PORCH	201		74.40	14,954		
				FLOOR COVER	99	N/A	1.00	E	WDK	N	WOOD DECK	16		31.63	506		
				INT FINISH	99	N/A	1.00										
				HEATING/COOLING	2	HOT WATER	1.02										
				FUEL SOURCE	2	GAS	1.00										
				ARPUD	0		1.00										
				AFFORDABLE	0		1.00										
																CONDITION ELEM	CD
																EXTERIOR	
																INTERIOR	
																KITCHEN	
																BATHS	
																HEAT	
																ELECT	
																EFF.YR/AGE	1951 / 70
																COND	64 64 %
																FUNC	0
																ECON	0
																DEPR	64 % GD 36
																RCNLD	\$116,400