

| CURRENT OWNER   |  | TOPO  | UTILITIES | STRT / ROAD   | LOCATION | CURRENT ASSESSMENT |      |           |          |               |
|---|--|---|-----------|---------------|----------|--------------------|------|-----------|----------|---------------|
| DASILVA ALEX O  |  |   |           | 9 Town Street |          | Description        | Code | Appraised | Assessed | 1302          |
| PO BOX 558  |  |   |           | 1 Paved       |          | RESIDENTL          | 1010 | 499,100   | 499,100  |               |
| EDGARTOWN MA 02539  |  | <b>SUPPLEMENTAL DATA</b>  |           |               |          | RES LND            | 1010 | 332,500   | 332,500  | EDGARTOWN, MA |
| Alt Prcl ID<br>PLN#/Rec<br>Lot#<br>Plan Notes<br>Plan Notes<br>Plan Notes |  | Restriction<br>Hist Distrct<br>Other Note<br>UC-Misc 1<br>UC-Misc 2 |           |               |          |                    |      |           |          | <b>VISION</b> |
| GIS ID M_279382_795223  |  | Assoc Pid#  |           |               |          |                    |      |           |          |               |
|   |  |   |           |               |          | Total              |      | 831,600   | 831,600  |               |

| RECORD OF OWNERSHIP |       | BK-VOL/PAGE | SALE DATE  | Q/U | V/I | SALE PRICE | VC | PREVIOUS ASSESSMENTS (HISTORY) |      |          |       |      |          |       |  |         |
|---------------------|-------|-------------|------------|-----|-----|------------|----|--------------------------------|------|----------|-------|------|----------|-------|--|---------|
| DASILVA ALEX O      | 01613 | 731         | 02-10-2022 | Q   | I   | 827,500    | 00 | Year                           | Code | Assessed | Year  | Code | Assessed |       |  |         |
| REYNOLDS W PHILIP   | 0848  | 0044        | 08-31-2001 | U   | I   | 1          | 1A | 2023                           | 1010 | 473,700  | 2022  | 1010 | 297,300  |       |  |         |
| SEACORD CAROLINE O  | 0465  | 0768        |            | Q   | I   | 0          | 00 |                                | 1010 | 301,700  | 2021  | 1010 | 301,700  |       |  |         |
|                     |       |             |            |     |     |            |    | Total                          |      | 775,400  | Total |      | 599,000  | Total |  | 577,200 |

| EXEMPTIONS |      |             | OTHER ASSESSMENTS |      |             |        |        |          |
|------------|------|-------------|-------------------|------|-------------|--------|--------|----------|
| Year       | Code | Description | Amount            | Code | Description | Number | Amount | Comm Int |
|            |      |             |                   |      |             |        |        |          |
| Total      |      |             | 0.00              |      |             |        |        |          |

| ASSESSING NEIGHBORHOOD |           |   |         |
|------------------------|-----------|---|---------|
| Nbhd                   | Nbhd Name | B | Tracing |
| 0040                   |           |   |         |

  

| APPRAISED VALUE SUMMARY       |         |
|-------------------------------|---------|
| Appraised Bldg. Value (Card)  | 494,700 |
| Appraised Xf (B) Value (Bldg) | 2,800   |
| Appraised Ob (B) Value (Bldg) | 1,600   |
| Appraised Land Value (Bldg)   | 332,500 |
| Special Land Value            | 0       |
| Total Appraised Parcel Value  | 831,600 |
| Valuation Method              | C       |
| Total Appraised Parcel Value  | 831,600 |

| BUILDING PERMIT RECORD |            |      |               |        |            |        |           | VISIT / CHANGE HISTORY  |            |    |      |    |    |                       |
|------------------------|------------|------|---------------|--------|------------|--------|-----------|-------------------------|------------|----|------|----|----|-----------------------|
| Permit Id              | Issue Date | Type | Description   | Amount | Insp Date  | % Comp | Date Comp | Comments                | Date       | Id | Type | Is | Cd | Purpost/Result        |
| 2019-381               | 12-21-2018 | RA   | Res Add/Alter | 8,000  |            | 0      |           | ADD EGRESS WINDOW FRO   | 06-16-2023 | PR |      |    | 00 | Measur+Listed         |
| 2005:286               | 06-01-2005 | RN   | Res New Cons  |        | 01-04-2006 | 100    |           | POLY GARAGE/SHED 12 X 2 | 05-31-2022 | DM |      |    | 11 | Field Review          |
|                        |            |      |               |        |            |        |           |                         | 03-18-2019 | EP |      |    | 01 | Cyclical Reinspection |
|                        |            |      |               |        |            |        |           |                         | 05-24-2017 | AU |      |    | 11 | Field Review          |
|                        |            |      |               |        |            |        |           |                         | 09-23-2014 | EP |      |    | 01 | Cyclical Reinspection |
|                        |            |      |               |        |            |        |           |                         | 11-10-2011 | RK |      |    | 11 | Field Review          |
|                        |            |      |               |        |            |        |           |                         | 01-04-2006 | WP |      |    | 50 | UC Status Inspection  |

| LAND LINE VALUATION SECTION |          |               |      |           |            |                        |          |            |       |       |           |                  |                     |            |            |         |
|-----------------------------|----------|---------------|------|-----------|------------|------------------------|----------|------------|-------|-------|-----------|------------------|---------------------|------------|------------|---------|
| B                           | Use Code | Description   | Zone | Land Type | Land Units | Unit Price             | Size Adj | Site Index | Cond. | Nbhd. | Nbhd. Adj | Notes            | Location Adjustment | Adj Unit P | Land Value |         |
| 1                           | 1010     | SINGL FAM M-0 | R20  |           | 21,000 SF  | 15.08                  | 1.00000  | 4          | 1.00  | 0040  | 1.050     |                  |                     | 15.84      | 332,500    |         |
| Total Card Land Units       |          |               |      |           | 0.48 AC    | Parcel Total Land Area |          |            |       |       | 0.48      | Total Land Value |                     |            |            | 332,500 |

| CONSTRUCTION DETAIL            |      |                | CONSTRUCTION DETAIL (CONTINUED) |     |             |
|--------------------------------|------|----------------|---------------------------------|-----|-------------|
| Element                        | Cd   | Description    | Element                         | Cd  | Description |
| Style:                         | 04   | Cape Cod       |                                 |     |             |
| Model                          | 01   | Residential    |                                 |     |             |
| Grade:                         | 04   | Above Ave      |                                 |     |             |
| Stories:                       | 1.5  | 1 1/2 Stories  |                                 |     |             |
| Occupancy                      | 1    |                |                                 |     |             |
| Exterior Wall 1                | 14   | Wood Shingle   |                                 |     |             |
| Exterior Wall 2                | 25   | Vinyl Siding   |                                 |     |             |
| Roof Structure:                | 03   | Gable/Hip      |                                 |     |             |
| Roof Cover                     | 03   | Asph/F Gls/Cmp |                                 |     |             |
| Interior Wall 1                | 06   | Cust Wd Panel  |                                 |     |             |
| Interior Wall 2                | 05   | Drywall/Sheet  |                                 |     |             |
| Interior Flr 1                 | 12   | Hardwood       |                                 |     |             |
| Interior Flr 2                 | 14   | Carpet         |                                 |     |             |
| Heat Fuel                      | 02   | Oil            |                                 |     |             |
| Heat Type:                     | 05   | Hot Water      |                                 |     |             |
| AC Type:                       | 01   | None           |                                 |     |             |
| Total Bedrooms                 | 03   | 3 Bedrooms     |                                 |     |             |
| Total Bthrms:                  | 1    |                |                                 |     |             |
| Total Half Baths               | 0    |                |                                 |     |             |
| Total Xtra Fixtrs              |      |                |                                 |     |             |
| Total Rooms:                   | 5    |                |                                 |     |             |
| Bath Style:                    | 02   | Average        |                                 |     |             |
| Kitchen Style:                 | 02   | Modern         |                                 |     |             |
| <b>CONDO DATA</b>              |      |                |                                 |     |             |
| Parcel Id                      |      | C              | Owne                            | 0.0 |             |
| Adjust Type                    | Code | Description    | Factor%                         |     |             |
| Condo Flr                      |      |                |                                 |     |             |
| Condo Unit                     |      |                |                                 |     |             |
| <b>COST / MARKET VALUATION</b> |      |                |                                 |     |             |
| Building Value New             |      |                | 618,330                         |     |             |
| Year Built                     |      |                | 1970                            |     |             |
| Effective Year Built           |      |                | 2002                            |     |             |
| Depreciation Code              |      |                | G                               |     |             |
| Remodel Rating                 |      |                |                                 |     |             |
| Year Remodeled                 |      |                |                                 |     |             |
| Depreciation %                 |      |                | 20                              |     |             |
| Functional Obsol               |      |                | 0                               |     |             |
| External Obsol                 |      |                | 0                               |     |             |
| Trend Factor                   |      |                | 1                               |     |             |
| Condition                      |      |                |                                 |     |             |
| Condition %                    |      |                |                                 |     |             |
| Percent Good                   |      |                | 80                              |     |             |
| Cns Sect Rcnd                  |      |                | 494,700                         |     |             |
| Dep % Ovr                      |      |                |                                 |     |             |
| Dep Ovr Comment                |      |                |                                 |     |             |
| Misc Imp Ovr                   |      |                |                                 |     |             |
| Misc Imp Ovr Comment           |      |                |                                 |     |             |
| Cost to Cure Ovr               |      |                |                                 |     |             |
| Cost to Cure Ovr Comment       |      |                |                                 |     |             |

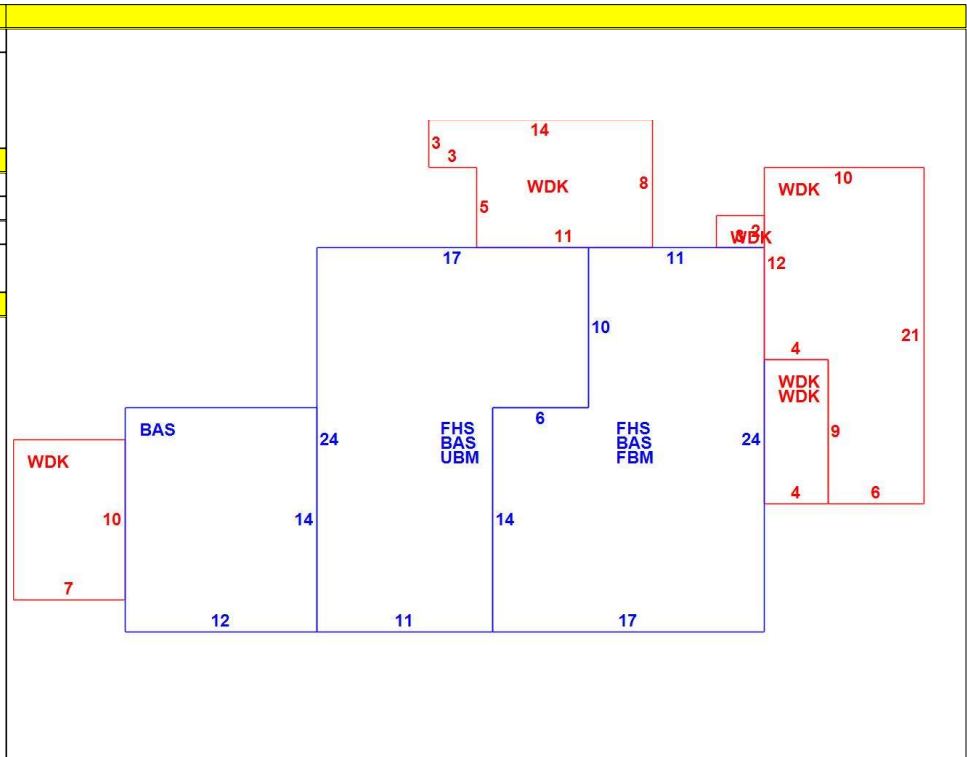

| OB - OUTBUILDING & YARD ITEMS(L) / XF - BUILDING EXTRA FEATURES(B) |             |     |       |            |        |          |      |       |            |             |
|--|-------------|-----|-------|------------|--------|----------|------|-------|------------|-------------|
| Code   | Description | L/B | Units | Unit Price | Yr Blt | Cond. Cd | % Gd | Grade | Grade Adj. | Appr. Value |
| FPL2   | FPL MSNRY 1 | B   | 1     | 3500.00    | 1991   |          | 80   |       | 0.00       | 2,800       |
| SHD1   | SHED FRAME  | L   | 80    | 16.00      | 1980   |          | 70   |       | 0.00       | 900         |
| ODP  | OUTDOOR PL  | L   | 1     | 700.00     |        |          | 100  |       | 0.00       | 700         |

| BUILDING SUB-AREA SUMMARY SECTION |                      |             |            |          |           |                |
|-----------------------------------|----------------------|-------------|------------|----------|-----------|----------------|
| Code                              | Description          | Living Area | Floor Area | Eff Area | Unit Cost | Undeprec Value |
| BAS                               | First Floor          | 840         | 840        | 840      | 429.40    | 360,693        |
| FBM                               | Basement, Finished   | 0           | 348        | 157      | 193.72    | 67,415         |
| FHS                               | Half Story, Finished | 336         | 672        | 336      | 214.70    | 144,277        |
| UBM                               | Basement, Unfinished | 0           | 324        | 65       | 86.14     | 27,911         |
| WDK                               | Deck, Wood           | 0           | 419        | 42       | 43.04     | 18,035         |
| Ttl Gross Liv / Lease Area        |                      | 1,176       | 2,603      | 1,440    |           | 618,331        |

