

| CURRENT OWNER                 |  | TOPO                     | UTILITIES | STRT / ROAD | LOCATION | CURRENT ASSESSMENT |      |           |           |               |
|-------------------------------|--|--------------------------|-----------|-------------|----------|--------------------|------|-----------|-----------|---------------|
| REAVES DONALD J & REAVES DEBO |  |                          |           |             |          | Description        | Code | Appraised | Assessed  | 1302          |
| REAVES KATHERINE ROSS         |  |                          |           |             |          | RESIDENTL          | 1090 | 1,632,300 | 1,632,300 |               |
| 8102 CHAMPIONSHIP COURT       |  |                          |           |             |          | RES LND            | 1090 | 854,900   | 854,900   | EDGARTOWN, MA |
| LAKEWOOD RANCH FL 34202-2586  |  | <b>SUPPLEMENTAL DATA</b> |           |             |          |                    |      |           |           | <b>VISION</b> |
| Alt Prcl ID                   |  | Restriction              |           |             |          |                    |      |           |           |               |
| PLN#/Rec BK213 PG515          |  | Hist District            |           |             |          |                    |      |           |           |               |
| Lot#                          |  | Other Note               |           |             |          |                    |      |           |           |               |
| Plan Notes                    |  | UC-Misc 1                |           |             |          |                    |      |           |           |               |
| Plan Notes                    |  | UC-Misc 2                |           |             |          |                    |      |           |           |               |
| Plan Notes                    |  |                          |           |             |          |                    |      |           |           |               |
| GIS ID M_281077_794699        |  | Assoc Pid#               |           |             |          |                    |      |           |           |               |
|                               |  |                          |           |             |          | Total              |      | 2,487,200 | 2,487,200 |               |

| RECORD OF OWNERSHIP                |      | BK-VOL/PAGE | SALE DATE  | Q/U | VI | SALE PRICE | VC | PREVIOUS ASSESSMENTS (HISTORY) |      |           |       |      |           |       |           |
|------------------------------------|------|-------------|------------|-----|----|------------|----|--------------------------------|------|-----------|-------|------|-----------|-------|-----------|
| REAVES DONALD J & REAVES DEBORAH R | 1537 | 640         | 07-31-2020 | Q   | I  | 1,850,000  | 00 | Year                           | Code | Assessed  | Year  | Code | Assessed  |       |           |
| FRIEDMAN JACQUELINE                | 1484 | 0326        | 12-19-2018 | Q   | I  | 1,250,000  | 00 | 2023                           | 1090 | 1,311,700 | 2022  | 1090 | 853,600   |       |           |
| THOMAS INGRID--TRS                 | 1138 | 0042        | 12-11-2007 | U   | I  | 1          | 1A |                                | 1090 | 886,600   |       | 1090 | 862,100   |       |           |
| THOMAS INGRID                      | 0725 | 0762        | 04-03-1998 | U   | I  | 1          | 1A |                                |      |           | 2021  | 1090 | 804,800   |       |           |
| THOMAS INGRID TRS                  | 097P | 0025        | 05-21-1997 | U   | I  | 1          | 1A |                                |      |           |       | 1090 | 749,000   |       |           |
|                                    |      |             |            |     |    |            |    | Total                          |      | 2,198,300 | Total |      | 1,715,700 | Total | 1,553,800 |

| EXEMPTIONS |      |             | OTHER ASSESSMENTS |      |             |        |        |          |
|------------|------|-------------|-------------------|------|-------------|--------|--------|----------|
| Year       | Code | Description | Amount            | Code | Description | Number | Amount | Comm Int |
|            |      |             |                   |      |             |        |        |          |
| Total      |      |             | 0.00              |      |             |        |        |          |

| ASSESSING NEIGHBORHOOD |           |   |         |
|------------------------|-----------|---|---------|
| Nbhd                   | Nbhd Name | B | Tracing |
| 0050                   |           |   | Batch   |

| NOTES                                 |  |   |  |
|---------------------------------------|--|---|--|
| 3-CAR FGR WITH LOWER LEVEL (WAS BARN) |  |   |  |
| =2 OB'S                               |  |   |  |
|                                       |  | PARCELS 1&2 ON 1138/42 & PRIOR DEEDS; WAS |  |
|                                       |  | PCLS12-35 & 21-4 THRU F15; AC CORR PER    |  |
|                                       |  | GIS AND 21-4 MERGED WITH 12-35 FY16       |  |
| LANDSCAPE EASEMENT OVER PART OF 12-36 |  | SEE ASSOC DOCS                            |  |
| SEE 1252/483                          |  |   |  |

| BUILDING PERMIT RECORD |            |      |               |         |           |        | VISIT / CHANGE HISTORY |              |            |    |      |    |    |                       |
|------------------------|------------|------|---------------|---------|-----------|--------|------------------------|--------------|------------|----|------|----|----|-----------------------|
| Permit Id              | Issue Date | Type | Description   | Amount  | Insp Date | % Comp | Date Comp              | Comments     | Date       | Id | Type | Is | Cd | Purpost/Result        |
| 2021-641               | 03-10-2021 | RA   | Res Add/Alter | 100,000 |           |        |                        | RENO KITCHEN | 05-23-2022 | DM |      |    | 11 | Field Review          |
|                        |            |      |               |         |           |        |                        |              | 05-11-2021 | EH |      |    | 01 | Cyclical Reinspection |
|                        |            |      |               |         |           |        |                        |              | 05-23-2017 | MM |      |    | 11 | Field Review          |
|                        |            |      |               |         |           |        |                        |              | 11-30-2011 | DM |      |    | 11 | Field Review          |
|                        |            |      |               |         |           |        |                        |              | 10-29-2010 | EP |      |    | 01 | Cyclical Reinspection |
|                        |            |      |               |         |           |        |                        |              | 04-20-2004 | CR |      |    | 01 | Cyclical Reinspection |
|                        |            |      |               |         |           |        |                        |              | 09-18-1978 |    |      |    |    |                       |

| LAND LINE VALUATION SECTION |          |             |      |           |            |            |                        |            |       |       |           |       |                     |            |            |         |
|-----------------------------|----------|-------------|------|-----------|------------|------------|------------------------|------------|-------|-------|-----------|-------|---------------------|------------|------------|---------|
| B                           | Use Code | Description | Zone | Land Type | Land Units | Unit Price | Size Adj               | Site Index | Cond. | Nbhd. | Nbhd. Adj | Notes | Location Adjustment | Adj Unit P | Land Value |         |
| 1                           | 1090     | MULTI HSES  | R60  |           | 65,340     | SF         | 6.54                   | 1.00000    | 6     | 1.00  | 0050      | 1.800 |                     | 11.77      | 769,200    |         |
| 1                           | 1090     | MULTI HSES  | R60  |           | 1.400      | AC         | 34,000.00              | 1.00000    | 0     | 1.00  | 0050      | 1.800 |                     | 61,200     | 85,700     |         |
| Total Card Land Units       |          |             |      |           | 2.90       | AC         | Parcel Total Land Area |            |       |       |           | 2.90  | Total Land Value    |            |            | 854,900 |

| CONSTRUCTION DETAIL      |      |                | CONSTRUCTION DETAIL (CONTINUED) |          |             |
|--------------------------|------|----------------|---------------------------------|----------|-------------|
| Element                  | Cd   | Description    | Element                         | Cd       | Description |
| Style:                   | 01   | Ranch          |                                 |          |             |
| Model                    | 01   | Residential    |                                 |          |             |
| Grade:                   | 06   | Good           |                                 |          |             |
| Stories:                 | 1    | 1 Story        |                                 |          |             |
| Occupancy                | 1    |                |                                 |          |             |
| Exterior Wall 1          | 14   | Wood Shingle   |                                 |          |             |
| Exterior Wall 2          |      |                |                                 |          |             |
| Roof Structure:          | 03   | Gable/Hip      |                                 |          |             |
| Roof Cover               | 03   | Asph/F Gls/Cmp |                                 |          |             |
| Interior Wall 1          | 05   | Drywall/Sheet  |                                 |          |             |
| Interior Wall 2          | 06   | Cust Wd Panel  |                                 |          |             |
| Interior Flr 1           | 12   | Hardwood       |                                 |          |             |
| Interior Flr 2           | 15   | Quarry Tile    |                                 |          |             |
| Heat Fuel                | 03   | Gas            |                                 |          |             |
| Heat Type:               | 03   | Hot Air-no Duc |                                 |          |             |
| AC Type:                 | 02   | Heat Pump      |                                 |          |             |
| Total Bedrooms           | 03   | 3 Bedrooms     |                                 |          |             |
| Total Bthrms:            | 3    |                |                                 |          |             |
| Total Half Baths         | 0    |                |                                 |          |             |
| Total Xtra Fixtrs        |      |                |                                 |          |             |
| Total Rooms:             | 6    |                |                                 |          |             |
| Bath Style:              | 03   | Modern         |                                 |          |             |
| Kitchen Style:           | 03   | Luxurious      |                                 |          |             |
|                          |      |                | <b>CONDO DATA</b>               |          |             |
| Parcel Id                |      |                | C                               | Owne 0.0 |             |
|                          |      |                | B                               | S        |             |
| Adjust Type              | Code | Description    | Factor%                         |          |             |
| Condo Flr                |      |                |                                 |          |             |
| Condo Unit               |      |                |                                 |          |             |
|                          |      |                | <b>COST / MARKET VALUATION</b>  |          |             |
| Building Value New       |      | 1,916,285      |                                 |          |             |
| Year Built               |      | 1960           |                                 |          |             |
| Effective Year Built     |      | 2002           |                                 |          |             |
| Depreciation Code        |      | G              |                                 |          |             |
| Remodel Rating           |      |                |                                 |          |             |
| Year Remodeled           |      |                |                                 |          |             |
| Depreciation %           |      | 20             |                                 |          |             |
| Functional Obsol         |      | 0              |                                 |          |             |
| External Obsol           |      | 0              |                                 |          |             |
| Trend Factor             |      | 1              |                                 |          |             |
| Condition                |      |                |                                 |          |             |
| Condition %              |      |                |                                 |          |             |
| Percent Good             |      | 80             |                                 |          |             |
| Cns Sect Rcnd            |      | 1,533,000      |                                 |          |             |
| Dep % Ovr                |      |                |                                 |          |             |
| Dep Ovr Comment          |      |                |                                 |          |             |
| Misc Imp Ovr             |      |                |                                 |          |             |
| Misc Imp Ovr Comment     |      |                |                                 |          |             |
| Cost to Cure Ovr         |      |                |                                 |          |             |
| Cost to Cure Ovr Comment |      |                |                                 |          |             |

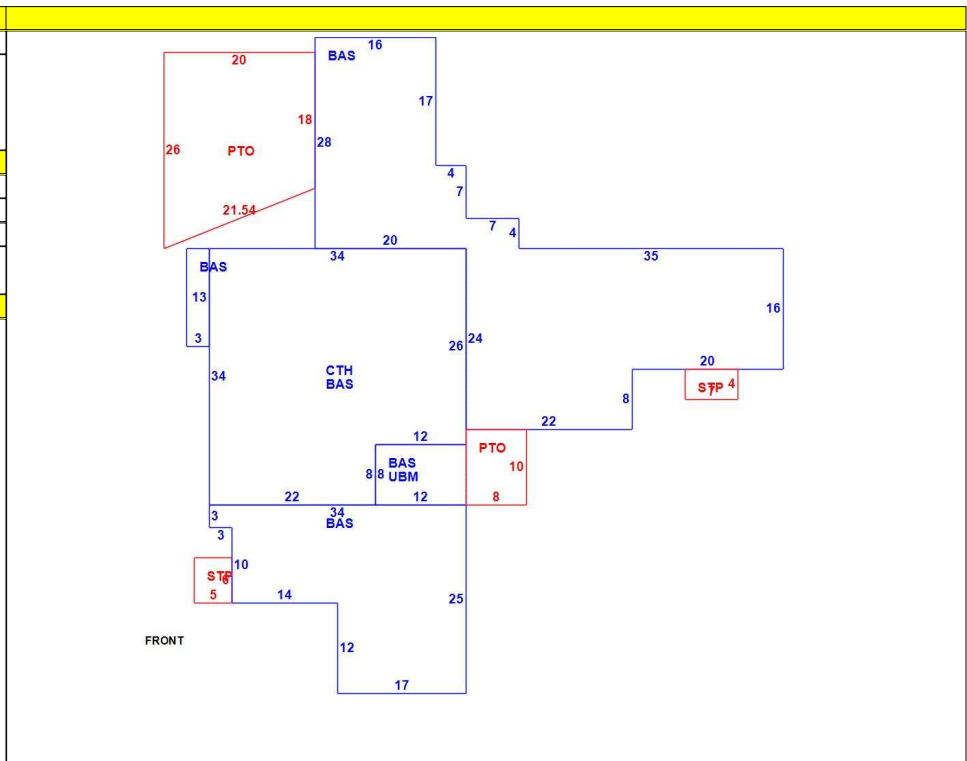

**OB - OUTBUILDING & YARD ITEMS(L) / XF - BUILDING EXTRA FEATURES(B)**

| Code | Description | L/B | Units | Unit Price | Yr Blt | Cond. Cd | % Gd | Grade | Grade Adj. | Appr. Value |
|------|-------------|-----|-------|------------|--------|----------|------|-------|------------|-------------|
| FPL1 | FPL MSNRY 1 | B   | 1     | 3000.00    | 1996   |          | 80   |       | 0.00       | 2,400       |
| FGR2 | GAR 1ST-GO  | L   | 840   | 35.00      | 1980   |          | 70   |       | 0.00       | 20,600      |
| MSC1 | GAR LOWER   | L   | 784   | 20.00      | 1980   |          | 70   |       | 0.00       | 11,000      |

**BUILDING SUB-AREA SUMMARY SECTION**

| Code                       | Description          | Living Area | Floor Area | Eff Area | Unit Cost | Undeprec Value |
|----------------------------|----------------------|-------------|------------|----------|-----------|----------------|
| BAS                        | First Floor          | 3,179       | 3,179      | 3,179    | 574.88    | 1,827,550      |
| CTH                        | Cath Cing            | 0           | 1,060      | 53       | 28.74     | 30,469         |
| PTO                        | Patio                | 0           | 520        | 52       | 57.49     | 29,894         |
| STP                        | Stoop                | 0           | 58         | 6        | 59.47     | 3,449          |
| UBM                        | Basement, Unfinished | 0           | 96         | 19       | 113.78    | 10,923         |
| Ttl Gross Liv / Lease Area |                      | 3,179       | 4,913      | 3,309    |           | 1,902,285      |



| CURRENT OWNER   |  | TOPO | UTILITIES                                 | STRT / ROAD | LOCATION | CURRENT ASSESSMENT   |              |                      |                      |                       |
|---|--|------|---|-------------|----------|----------------------|--------------|----------------------|----------------------|-----------------------|
| REAVES DONALD J & REAVES DEBO<br>REAVES KATHERINE ROSS<br>8102 CHAMPIONSHIP COURT<br><br>LAKEWOOD RANCH FL 34202-2586 |  |      |   |             |          | Description          | Code         | Appraised            | Assessed             | 1302<br>EDGARTOWN, MA |
|   |  |      |   |             |          | RESIDENTL<br>RES LND | 1090<br>1090 | 1,632,300<br>854,900 | 1,632,300<br>854,900 |                       |
| SUPPLEMENTAL DATA   |  |      |   |             |          |                      |              |                      |                      |                       |
| Alt Prcl ID<br>PLN#/Rec BK213 PG515   |  |      | Restriction<br>Hist Distrct<br>Other Note |             |          |                      |              |                      |                      |                       |
| Lot#<br>Plan Notes<br>Plan Notes<br>Plan Notes  |  |      | UC-Misc 1<br>UC-Misc 2                    |             |          |                      |              |                      |                      |                       |
| GIS ID M_281077_794699  |  |      | Assoc Pid#                                |             |          |                      |              |                      |                      |                       |
|   |  |      |   |             |          | Total                | 2,487,200    | 2,487,200            |                      |                       |

**VISION**

| RECORD OF OWNERSHIP                |           | BK-VOL/PAGE | SALE DATE | Q/U | V/I       | SALE PRICE | VC    | PREVIOUS ASSESSMENTS (HISTORY) |           |           |       |           |      |      |          |
|------------------------------------|-----------|-------------|-----------|-----|-----------|------------|-------|--------------------------------|-----------|-----------|-------|-----------|------|------|----------|
| REAVES DONALD J & REAVES DEBORAH R | 1537 640  | 07-31-2020  | Q         | I   | 1,850,000 | 00         | Year  | Code                           | Assessed  | Year      | Code  | Assessed  | Year | Code | Assessed |
| FRIEDMAN JACQUELINE                | 1484 0326 | 12-19-2018  | Q         | I   | 1,250,000 | 00         | 2023  | 1090                           | 1,311,700 | 2022      | 1090  | 853,600   | 2021 | 1090 | 804,800  |
| THOMAS INGRID--TRS                 | 1138 0042 | 12-11-2007  | U         | I   | 1         | 1A         |       | 1090                           | 886,600   |           | 1090  | 862,100   |      | 1090 | 749,000  |
| THOMAS INGRID                      | 0725 0762 | 04-03-1998  | U         | I   | 1         | 1A         |       |                                |           |           |       |           |      |      |          |
| THOMAS INGRID TRS                  | 097P 0025 | 05-21-1997  | U         | I   | 1         | 1A         |       |                                |           |           |       |           |      |      |          |
|                                    |           |             |           |     |           |            | Total | 2,198,300                      | Total     | 1,715,700 | Total | 1,553,800 |      |      |          |

| EXEMPTIONS |      |             | OTHER ASSESSMENTS |      |             |        | This signature acknowledges a visit by a Data Collector or Assessor |          |  |  |  |  |  |  |
|------------|------|-------------|-------------------|------|-------------|--------|---|----------|--|--|--|--|--|--|
| Year       | Code | Description | Amount            | Code | Description | Number | Amount  | Comm Int |  |  |  |  |  |  |
|            |      | Total       | 0.00              |      |             |        |   |          |  |  |  |  |  |  |

| ASSESSING NEIGHBORHOOD |           |   |         |       |                               | APPRAISED VALUE SUMMARY |  |  |  |  |           |
|------------------------|-----------|---|---------|-------|-------------------------------|-------------------------|--|--|--|--|-----------|
| Nbhd                   | Nbhd Name | B | Tracing | Batch |                               |                         |  |  |  |  |           |
| 0050                   |           |   |         |       | Appraised Bldg. Value (Card)  |                         |  |  |  |  | 1,595,100 |
|                        |           |   |         |       | Appraised Xf (B) Value (Bldg) |                         |  |  |  |  | 4,700     |
|                        |           |   |         |       | Appraised Ob (B) Value (Bldg) |                         |  |  |  |  | 32,500    |
|                        |           |   |         |       | Appraised Land Value (Bldg)   |                         |  |  |  |  | 854,900   |
|                        |           |   |         |       | Special Land Value            |                         |  |  |  |  | 0         |
|                        |           |   |         |       | Total Appraised Parcel Value  |                         |  |  |  |  | 2,487,200 |
|                        |           |   |         |       | Valuation Method              |                         |  |  |  |  | C         |
|                        |           |   |         |       | Total Appraised Parcel Value  |                         |  |  |  |  | 2,487,200 |

| BUILDING PERMIT RECORD |            |      |             |        |           |        |           |          |      | VISIT / CHANGE HISTORY |      |    |    |                |  |
|------------------------|------------|------|-------------|--------|-----------|--------|-----------|----------|------|------------------------|------|----|----|----------------|--|
| Permit Id              | Issue Date | Type | Description | Amount | Insp Date | % Comp | Date Comp | Comments | Date | Id                     | Type | Is | Cd | Purpost/Result |  |
|                        |            |      |             |        |           |        |           |          |      |                        |      |    |    |                |  |

| LAND LINE VALUATION SECTION |          |             |      |           |            |            |                        |            |       |       |           |       |                     |            |            |   |
|-----------------------------|----------|-------------|------|-----------|------------|------------|------------------------|------------|-------|-------|-----------|-------|---------------------|------------|------------|---|
| B                           | Use Code | Description | Zone | Land Type | Land Units | Unit Price | Size Adj               | Site Index | Cond. | Nbhd. | Nbhd. Adj | Notes | Location Adjustment | Adj Unit P | Land Value |   |
| 2                           | 1090     | MULTI HSES  | R60  |           | 0 SF       | 57.18      | 1.00000                | 6          | 1.00  | 0050  | 1.800     |       |                     | 102.92     | 0          |   |
| Total Card Land Units       |          |             |      |           | 0.00       | AC         | Parcel Total Land Area |            |       |       |           | 2.90  | Total Land Value    |            |            | 0 |

| CONSTRUCTION DETAIL            |      |                | CONSTRUCTION DETAIL (CONTINUED) |        |             |
|--------------------------------|------|----------------|---------------------------------|--------|-------------|
| Element                        | Cd   | Description    | Element                         | Cd     | Description |
| Style:                         | 36   | Camp           |                                 |        |             |
| Model                          | 01   | Residential    |                                 |        |             |
| Grade:                         | 03   | Average        |                                 |        |             |
| Stories:                       | 1    | 1 Story        |                                 |        |             |
| Occupancy                      | 1    |                |                                 |        |             |
| Exterior Wall 1                | 14   | Wood Shingle   |                                 |        |             |
| Exterior Wall 2                |      |                |                                 |        |             |
| Roof Structure:                | 03   | Gable/Hip      |                                 |        |             |
| Roof Cover                     | 03   | Asph/F Gls/Cmp |                                 |        |             |
| Interior Wall 1                | 05   | Drywall/Sheet  |                                 |        |             |
| Interior Wall 2                |      |                |                                 |        |             |
| Interior Flr 1                 | 12   | Hardwood       |                                 |        |             |
| Interior Flr 2                 |      |                |                                 |        |             |
| Heat Fuel                      | 02   | Oil            |                                 |        |             |
| Heat Type:                     | 01   | None           |                                 |        |             |
| AC Type:                       | 01   | None           |                                 |        |             |
| Total Bedrooms                 | 02   | 2 Bedrooms     |                                 |        |             |
| Total Bthrms:                  | 1    |                |                                 |        |             |
| Total Half Baths               | 0    |                |                                 |        |             |
| Total Xtra Fixtrs              |      |                |                                 |        |             |
| Total Rooms:                   | 4    |                |                                 |        |             |
| Bath Style:                    | 01   | Old Style      |                                 |        |             |
| Kitchen Style:                 | 01   | Old Style      |                                 |        |             |
| <b>CONDO DATA</b>              |      |                |                                 |        |             |
| Parcel Id                      |      | C              | Ownr                            | 0.0    |             |
|                                |      |                | B                               | S      |             |
| Adjust Type                    | Code | Description    | Factor%                         |        |             |
| Condo Flr                      |      |                |                                 |        |             |
| Condo Unit                     |      |                |                                 |        |             |
| <b>COST / MARKET VALUATION</b> |      |                |                                 |        |             |
| Building Value New             |      |                |                                 | 82,750 |             |
| Year Built                     |      |                |                                 | 1960   |             |
| Effective Year Built           |      |                |                                 | 1997   |             |
| Depreciation Code              |      |                |                                 | A      |             |
| Remodel Rating                 |      |                |                                 |        |             |
| Year Remodeled                 |      |                |                                 |        |             |
| Depreciation %                 |      |                |                                 | 25     |             |
| Functional Obsol               |      |                |                                 | 0      |             |
| External Obsol                 |      |                |                                 | 0      |             |
| Trend Factor                   |      |                |                                 | 1      |             |
| Condition                      |      |                |                                 |        |             |
| Condition %                    |      |                |                                 |        |             |
| Percent Good                   |      |                |                                 | 75     |             |
| Cns Sect Rcnd                  |      |                |                                 | 62,100 |             |
| Dep % Ovr                      |      |                |                                 |        |             |
| Dep Ovr Comment                |      |                |                                 |        |             |
| Misc Imp Ovr                   |      |                |                                 |        |             |
| Misc Imp Ovr Comment           |      |                |                                 |        |             |
| Cost to Cure Ovr               |      |                |                                 |        |             |
| Cost to Cure Ovr Comment       |      |                |                                 |        |             |

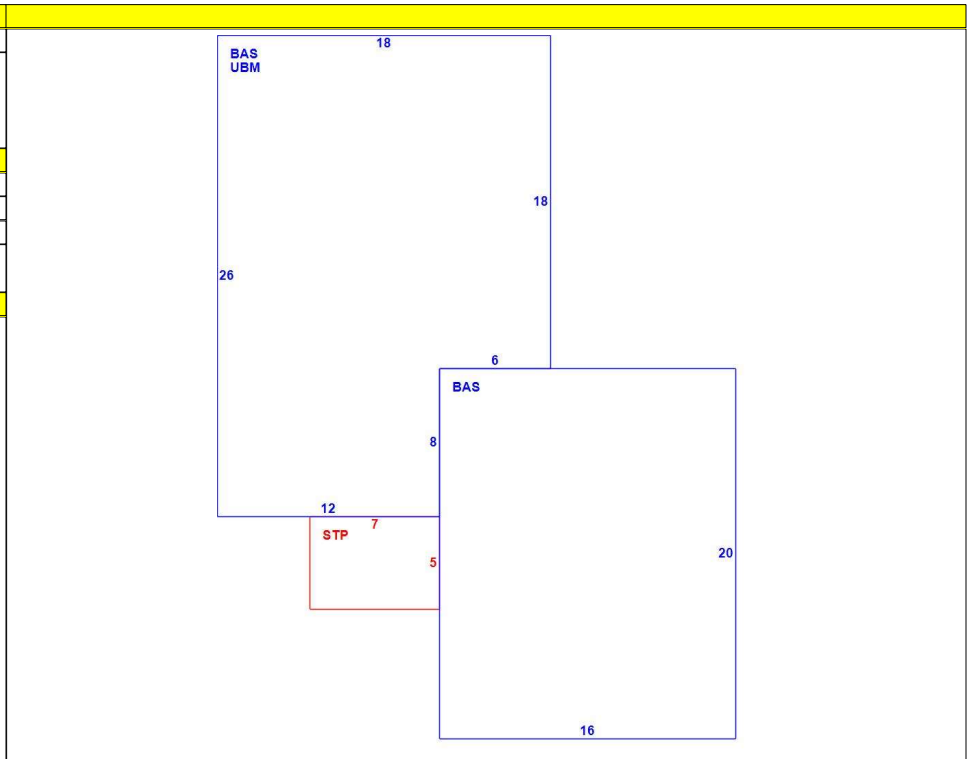

| OB - OUTBUILDING & YARD ITEMS(L) / XF - BUILDING EXTRA FEATURES(B) |             |     |       |            |        |          |      |       |            |             |
|--|-------------|-----|-------|------------|--------|----------|------|-------|------------|-------------|
| Code   | Description | L/B | Units | Unit Price | Yr Blt | Cond. Cd | % Gd | Grade | Grade Adj. | Appr. Value |
| FPL1   | FPL MSNRY 1 | B   | 1     | 3000.00    | 1991   |          | 75   |       | 0.00       | 2,300       |
| SHD1   | SHED FRAME  | L   | 112   | 16.00      | 1980   |          | 50   |       | 0.00       | 900         |

| BUILDING SUB-AREA SUMMARY SECTION |                      |             |            |          |           |                |
|-----------------------------------|----------------------|-------------|------------|----------|-----------|----------------|
| Code                              | Description          | Living Area | Floor Area | Eff Area | Unit Cost | Undeprec Value |
| BAS                               | First Floor          | 740         | 740        | 740      | 99.94     | 73,956         |
| STP                               | Stoop                | 0           | 35         | 4        | 11.42     | 400            |
| UBM                               | Basement, Unfinished | 0           | 420        | 84       | 19.99     | 8,395          |
| Ttl Gross Liv / Lease Area        |                      | 740         | 1,195      | 828      |           | 82,751         |

