

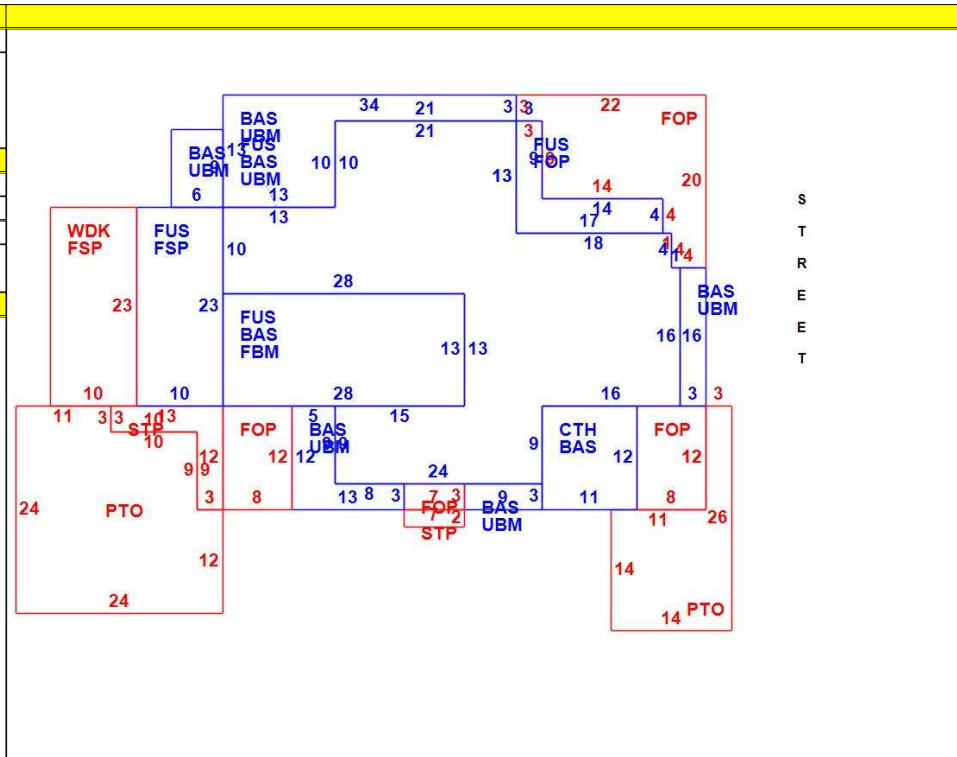

CONSTRUCTION DETAIL			CONSTRUCTION DETAIL (CONTINUED)		
Element	Cd	Description	Element	Cd	Description
Style:	06	Custom			
Model	01	Residential			
Grade:	09	Custom			
Stories:	1.75				
Occupancy	1				
Exterior Wall 1	14	Wood Shingle			
Exterior Wall 2					
Roof Structure:	03	Gable/Hip			
Roof Cover	10	Wood Shingle			
Interior Wall 1	03	Plastered			
Interior Wall 2	06	Cust Wd Panel			
Interior Flr 1	09	Pine/Soft Wood			
Interior Flr 2					
Heat Fuel	03	Gas			
Heat Type:	04	Forced Air-Duc			
AC Type:	03	Central			
Total Bedrooms	03	3 Bedrooms			
Total Bthrms:	3				
Total Half Baths	0				
Total Xtra Fixtrs					
Total Rooms:	7				
Bath Style:	03	Modern			
Kitchen Style:	03	Luxurious			
<b>CONDO DATA</b>					
Parcel Id		C	Owne		0.0
Adjust Type		Code	Description		Factor%
Condo Flr			Condo Unit		
<b>COST / MARKET VALUATION</b>					
Building Value New			3,964,607		
Year Built			2006		
Effective Year Built			2017		
Depreciation Code			G		
Remodel Rating					
Year Remodeled					
Depreciation %			5		
Functional Obsol			0		
External Obsol			0		
Trend Factor			1		
Condition					
Condition %					
Percent Good			95		
Cns Sect Rcnld			3,766,400		
Dep % Ovr					
Dep Ovr Comment					
Misc Imp Ovr					
Misc Imp Ovr Comment					
Cost to Cure Ovr					
Cost to Cure Ovr Comment					



**OB - OUTBUILDING & YARD ITEMS(L) / XF - BUILDING EXTRA FEATURES(B)**

Code	Description	L/B	Units	Unit Price	Yr Blt	Cond. Cd	% Gd	Grade	Grade Adj.	Appr. Value
FPL3	FPL MSNRY 2	B	1	4000.00	2011		95		0.00	3,800
FPO	EXTRA FPL O	B	1	800.00	2011		95		0.00	800

BUILDING SUB-AREA SUMMARY SECTION						
Code	Description	Living Area	Floor Area	Eff Area	Unit Cost	Undeprec Value
BAS	First Floor	2,161	2,161	2,161	803.59	1,736,549
CTH	Cath Clng	0	132	7	42.61	5,625
FBM	Basement, Finished	0	364	164	362.06	131,788
FOP	Porch, Open, Finished	0	581	116	160.44	93,216
FSP	Porch, Screen, Finished	0	460	115	200.90	92,412
FUS	Upper Story, Finished	1,909	1,909	1,909	803.59	1,534,046
PTO	Patio	0	742	74	80.14	59,465
STP	Stoop	0	80	8	80.36	6,429
UBM	Basement, Unfinished	0	1,665	333	160.72	267,594
WDK	Deck Wood	0	230	23	80.36	18,482
Ttl Gross Liv / Lease Area		4,070	8,324	4,910		3,945,606

