

CURRENT OWNER		TOPO	UTILITIES	STRT / ROAD	LOCATION	CURRENT ASSESSMENT											
13 WINDSOR DRIVE LLC			2 Public Water			Description	Code	Appraised	Assessed								
61 COBBLESTONE RD		SUPPLEMENTAL DATA				RESIDENTL	1010	496,100	496,100								
GLASTONBURY CT 06033		Alt Prcl ID PLN#/Rec Lot# Plan Notes Plan Notes Plan Notes GIS ID M_277488_795905				RES LND	1010	334,500	334,500								
		Restriction Hist District Other Note UC-Misc 1 UC-Misc 2 Assoc Pid#				Total		830,600	830,600								
RECORD OF OWNERSHIP		BK-VOL/PAGE	SALE DATE	Q/U	V/I	SALE PRICE	VC	PREVIOUS ASSESSMENTS (HISTORY)									
13 WINDSOR DRIVE LLC		0075 0121	12-11-2014	U	I	19,900	1A	Year	Code	Assessed	Year	Code	Assessed	Year	Code	Assessed	
KURKER-STEWART RALPH R &		00025 0395	10-01-1979					2023	1010	467,200	2022	1010	294,300	2021	1010	272,700	
									1010	303,500		1010	303,500		1010	303,500	
		Total						770,700		Total		597,800		Total		576,200	
EXEMPTIONS			OTHER ASSESSMENTS				This signature acknowledges a visit by a Data Collector or Assessor										
Year	Code	Description	Amount	Code	Description	Number	Amount	Comm Int									
			0.00														
ASSESSING NEIGHBORHOOD																	
Nbhd		Nbhd Name		B		Tracing		Batch									
0040																	
NOTES																	
LOT 5 LC 39292B MBLU CHANGE FOR FY 12 WAS 10-99.5																	
BUILDING PERMIT RECORD								VISIT / CHANGE HISTORY									
Permit Id	Issue Date	Type	Description	Amount	Insp Date	% Comp	Date Comp	Comments	Date	Id	Type	Is	Cd	Purpost/Result			
									08-18-2022	EH		6	01	Cyclical Reinspection			
									05-31-2022	LS			11	Field Review			
									05-18-2017	AU			11	Field Review			
									11-09-2011	RK			11	Field Review			
									08-06-2004	EP			51	Cyclical Reinspection			
									07-17-2000	WP			43	Cyclical Reinspection			
									02-25-1981								
LAND LINE VALUATION SECTION																	
B	Use Code	Description	Zone	Land Type	Land Units	Unit Price	Size Adj	Site Index	Cond.	Nbhd.	Nbhd. Adj	Notes	Location Adjustment	Adj Unit P	Land Value		
1	1010	SINGL FAM M-0	R60		22,096 SF	14.42	1.00000	4	1.00	0040	1.050			15.14	334,500		
Total Card Land Units					0.51 AC	Parcel Total Land Area					0.51	Total Land Value					334,500

VISION

1302
EDGARTOWN, MA

CONSTRUCTION DETAIL			CONSTRUCTION DETAIL (CONTINUED)		
Element	Cd	Description	Element	Cd	Description
Style:	04	Cape Cod			
Model:	01	Residential			
Grade:	04	Average +10			
Stories:	1.75				
Occupancy:	1				
Exterior Wall 1:	14	Wood Shingle			
Exterior Wall 2:					
Roof Structure:	03	Gable/Hip			
Roof Cover:	03	Asph/F GlS/Cmp			
Interior Wall 1:	05	Drywall/Sheet			
Interior Wall 2:					
Interior Flr 1:	14	Carpet			
Interior Flr 2:	05	Vinyl/Asphalt			
Heat Fuel:	04	Electric			
Heat Type:	07	Electr Basebrd			
AC Type:	01	None			
Total Bedrooms:	03	3 Bedrooms			
Total Bthrms:	2				
Total Half Baths:	0				
Total Xtra Fixtrs:					
Total Rooms:					
Bath Style:	02	Average			
Kitchen Style:					

CONDO DATA			
Parcel Id		C	Owne 0.0
		B	S
Adjust Type	Code	Description	Factor%
Condo Flr			
Condo Unit			

COST / MARKET VALUATION	
Building Value New	582,095
Year Built	1980
Effective Year Built	2007
Depreciation Code	A
Remodel Rating	
Year Remodeled	
Depreciation %	15
Functional Obsol	0
External Obsol	0
Trend Factor	1
Condition	
Condition %	
Percent Good	85
Cns Sect Rcnd	494,800
Dep % Ovr	
Dep Ovr Comment	
Misc Imp Ovr	
Misc Imp Ovr Comment	
Cost to Cure Ovr	
Cost to Cure Ovr Comment	

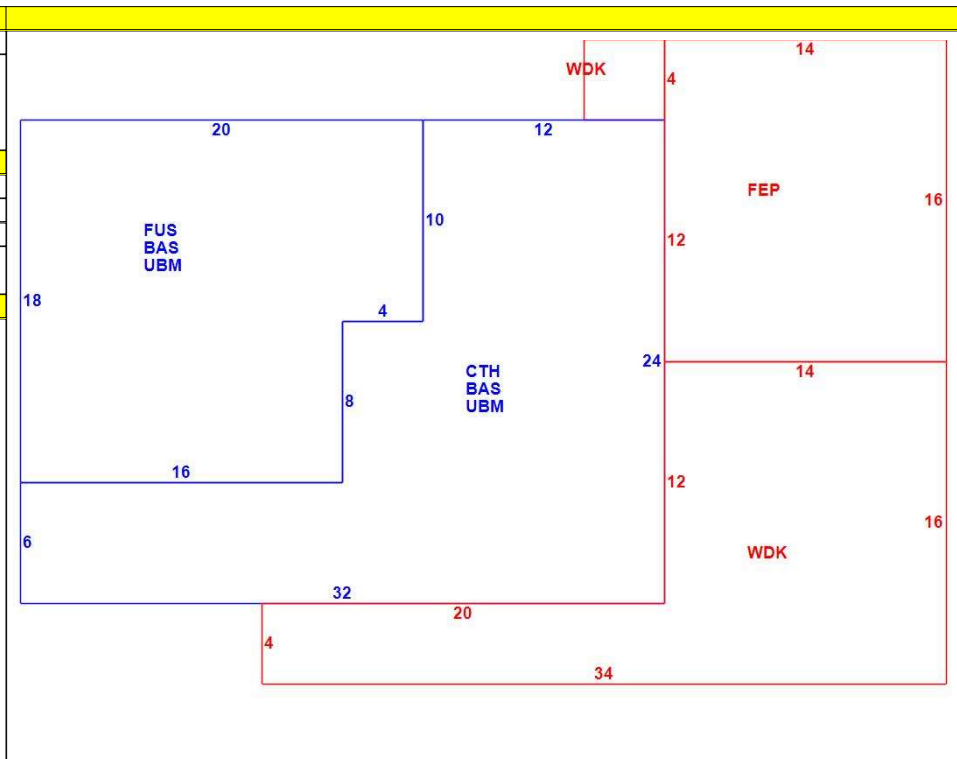

OB - OUTBUILDING & YARD ITEMS(L) / XF - BUILDING EXTRA FEATURES(B)										
Code	Description	L/B	Units	Unit Price	Yr Blt	Cond. Cd	% Gd	Grade	Grade Adj.	Appr. Value
SHD1	SHED FRAME	L	80	16.00	2004		100		0.00	1,300

BUILDING SUB-AREA SUMMARY SECTION						
Code	Description	Living Area	Floor Area	Eff Area	Unit Cost	Undeprec Value
BAS	First Floor	768	768	768	394.66	303,097
CTH	Cath Cing	0	440	22	19.73	8,682
FEP	Porch, Enclosed, Finished	0	224	157	276.61	61,961
FUS	Upper Story, Finished	328	328	328	394.66	129,448
UBM	Basement, Unfinished	0	768	154	79.14	60,777
WDK	Deck, Wood	0	320	32	39.47	12,629
Ttl Gross Liv / Lease Area		1,096	2,848	1,461		576,594

