

CONSTRUCTION DETAIL			CONSTRUCTION DETAIL (CONTINUED)		
Element	Cd	Description	Element	Cd	Description
Style:	04	Cape Cod			
Model:	01	Residential			
Grade:	05	Average +20			
Stories:	2	2 Stories			
Occupancy	1				
Exterior Wall 1	14	Wood Shingle			
Exterior Wall 2					
RooF Structure:	03	Gable/Hip			
RooF Cover	03	Asph/F Gls/Cmp			
Interior Wall 1	05	Drywall/Sheet			
Interior Wall 2					
Interior Flr 1	12	Hardwood			
Interior Flr 2	14	Carpet			
Heat Fuel	02	Oil			
Heat Type:	05	Hot Water			
AC Type:	01	None			
Total Bedrooms	05	5 Bedrooms			
Total Bthrms:	5				
Total Half Baths	0				
Total Xtra Fixtrs					
Total Rooms:	8	8 Rooms			
Bath Style:	02	Average			
Kitchen Style:	02	Modern			
CONDO DATA					
Parcel Id			C	Ownr	0.0
Adjust Type		Code	Description	Factor%	
Condo Flr					
Condo Unit					
COST / MARKET VALUATION					
Building Value New			1,578,339		
Year Built			1999		
Effective Year Built			2012		
Depreciation Code			A		
Remodel Rating					
Year Remodeled					
Depreciation %			10		
Functional Obsol			0		
External Obsol			0		
Trend Factor			1		
Condition					
Condition %					
Percent Good			90		
Cns Sect Rcnd			1,420,500		
Dep % Ovr					
Dep Ovr Comment					
Misc Imp Ovr					
Misc Imp Ovr Comment					
Cost to Cure Ovr					
Cost to Cure Ovr Comment					

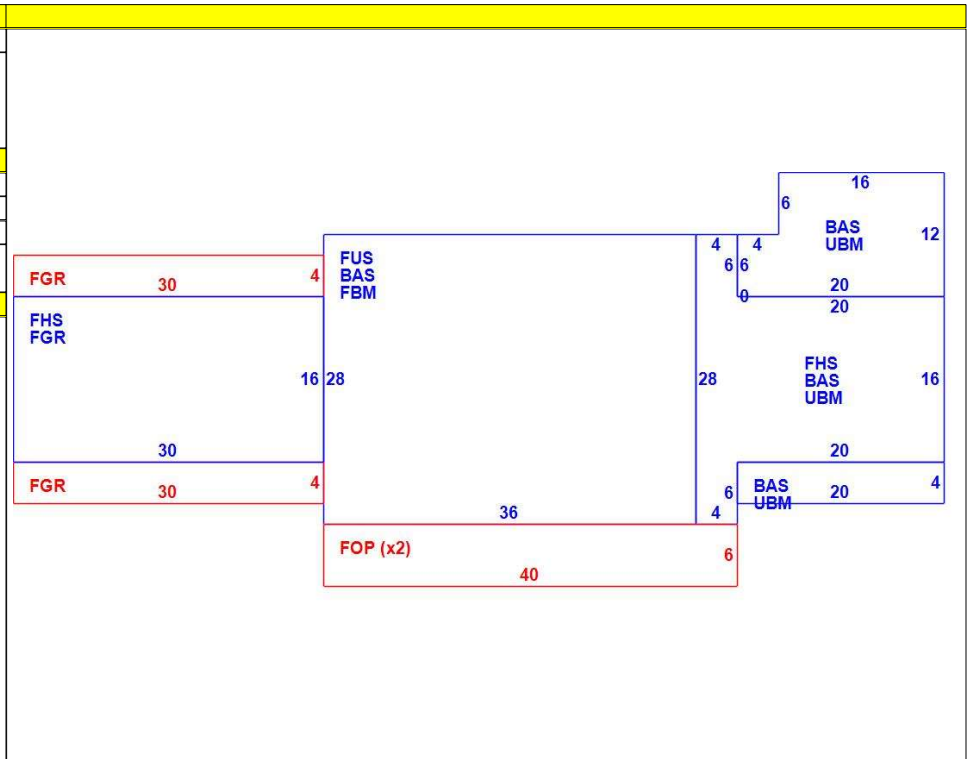

OB - OUTBUILDING & YARD ITEMS(L) / XF - BUILDING EXTRA FEATURES(B)										
Code	Description	L/B	Units	Unit Price	Yr Blt	Cond. Cd	% Gd	Grade	Grade Adj.	Appr. Value
SHED	SHED FRAME	L	1	1000.00	1980		70		0.00	700
PAT1	PATIO-AVG	L	720	4.50			100		0.00	3,200

BUILDING SUB-AREA SUMMARY SECTION						
Code	Description	Living Area	Floor Area	Eff Area	Unit Cost	Undeprec Value
BAS	First Floor	1,736	1,736	1,736	371.50	644,917
FBM	Basement, Finished	0	1,008	454	167.32	168,659
FGR	Garage	0	720	288	148.60	106,991
FHS	Half Story, Finished	456	912	456	185.75	169,402
FOP	Porch, Open, Finished	0	480	96	74.30	35,664
FUS	Upper Story, Finished	1,008	1,008	1,008	371.50	374,468
UBM	Basement, Unfinished	0	728	146	74.50	54,238
Ttl Gross Liv / Lease Area		3,200	6,592	4,184		1,554,339

