

CONSTRUCTION DETAIL			CONSTRUCTION DETAIL (CONTINUED)		
Element	Cd	Description	Element	Cd	Description
Style:	03	Colonial			
Model	01	Residential			
Grade:	05	Ave/Good			
Stories:	2	2 Stories			
Occupancy	2				
Exterior Wall 1	14	Wood Shingle			
Exterior Wall 2					
Roof Structure:	03	Gable/Hip			
Roof Cover	03	Asph/F Gls/Cmp			
Interior Wall 1	05	Drywall/Sheet			
Interior Wall 2					
Interior Flr 1	14	Carpet			
Interior Flr 2	12	Hardwood			
Heat Fuel	02	Oil			
Heat Type:	05	Hot Water			
AC Type:	01	None			
Total Bedrooms	03	3 Bedrooms			
Total Bthrms:	3				
Total Half Baths	0				
Total Xtra Fixtrs					
Total Rooms:					
Bath Style:					
Kitchen Style:					
			CONDO DATA		
			Parcel Id	C	Owne 0.0
			B S		
			Adjust Type	Code	Description
			Condo Flr		
			Condo Unit		
			COST / MARKET VALUATION		
			Building Value New		941,385
			Year Built		1989
			Effective Year Built		2012
			Depreciation Code		G
			Remodel Rating		
			Year Remodeled		
			Depreciation %		10
			Functional Obsol		0
			External Obsol		0
			Trend Factor		1
			Condition		
			Condition %		
			Percent Good		90
			Cns Sect Rcnd		847,200
			Dep % Ovr		
			Dep Ovr Comment		
			Misc Imp Ovr		
			Misc Imp Ovr Comment		
			Cost to Cure Ovr		
			Cost to Cure Ovr Comment		

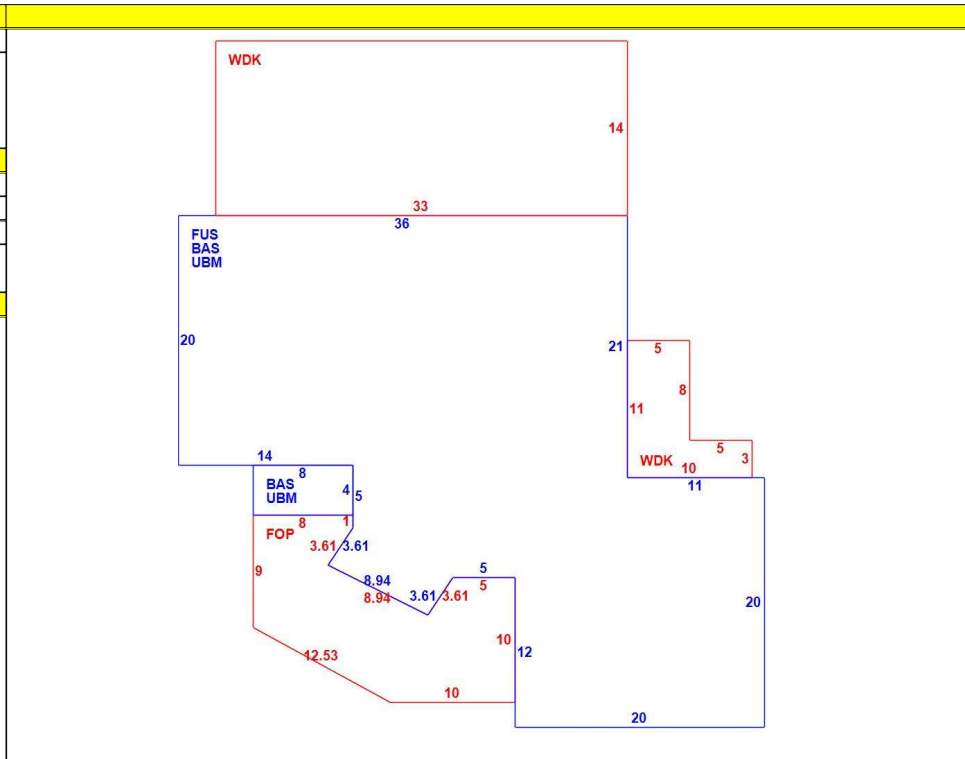

OB - OUTBUILDING & YARD ITEMS(L) / XF - BUILDING EXTRA FEATURES(B)

Code	Description	L/B	Units	Unit Price	Yr Blt	Cond. Cd	% Gd	Grade	Grade Adj.	Appr. Value
ODP	OUTDOOR PL	L	1	700.00			100		0.00	700
FPL	MTL-WD C/PI	B	1	2000.00	2006		90		0.00	1,800

BUILDING SUB-AREA SUMMARY SECTION

Code	Description	Living Area	Floor Area	Eff Area	Unit Cost	Undeprec Value
BAS	First Floor	1,294	1,294	1,294	319.60	413,557
FOP	Porch, Open, Finished	0	201	40	63.60	12,784
FUS	Upper Story, Finished	1,262	1,262	1,262	319.60	403,330
UBM	Basement, Unfinished	0	1,294	259	63.97	82,775
WDK	Deck, Wood	0	532	53	31.84	16,939
Ttl Gross Liv / Lease Area		2,556	4,583	2,908		929,385



CURRENT OWNER		TOPO	UTILITIES	STRT / ROAD	LOCATION	CURRENT ASSESSMENT				1302 EDGARTOWN, MA						
CREAN ROBERT M			3 Public Sewer			Description	Code	Appraised	Assessed			VISION				
BOX 2634		SUPPLEMENTAL DATA				RESIDENTL	1040	932,400	932,400							
OAK BLUFFS MA 02557		Alt Prcl ID PLN#/Rec Lot# Plan Notes Plan Notes Plan Notes GIS ID M_279076_793552				Restriction Hist Distrct Other Note UC-Misc 1 UC-Misc 2 Assoc Pid#		RES LND	1040	274,900	274,900					
						Total		1,207,300	1,207,300							
RECORD OF OWNERSHIP		BK-VOL/PAGE	SALE DATE	Q/U	V/I	SALE PRICE	VC	PREVIOUS ASSESSMENTS (HISTORY)								
CREAN ROBERT M		0545 0145	08-29-1990	U	I	1	1A	Year	Code	Assessed	Year	Code	Assessed			
CREAN ROBERT M.		0517 0004	02-27-1989	Q	V	72,500	00	2023	1040	921,800	2022	1040	713,700			
									1040	336,700	2021	1040	712,400			
												1040	323,200			
						Total		1,258,500	Total	1,069,100	Total	Total	1,035,600			
EXEMPTIONS			OTHER ASSESSMENTS				This signature acknowledges a visit by a Data Collector or Assessor									
Year	Code	Description	Amount	Code	Description	Number	Amount	Comm Int								
									APPRAISED VALUE SUMMARY							
Total			0.00					Appraised Bldg. Value (Card)				929,900				
								Appraised Xf (B) Value (Bldg)				1,800				
								Appraised Ob (B) Value (Bldg)				700				
								Appraised Land Value (Bldg)				274,900				
								Special Land Value				0				
								Total Appraised Parcel Value				1,207,300				
								Valuation Method				C				
								Total Appraised Parcel Value				1,207,300				
BUILDING PERMIT RECORD								VISIT / CHANGE HISTORY								
Permit Id	Issue Date	Type	Description	Amount	Insp Date	% Comp	Date Comp	Comments	Date	Id	Type	Is	Cd	Purpost/Result		
									03-16-2023	EH			01	Cyclical Reinspection		
									08-12-2020	EP			01	Cyclical Reinspection		
LAND LINE VALUATION SECTION																
B	Use Code	Description	Zone	Land Type	Land Units	Unit Price	Size Adj	Site Index	Cond.	Nbhd.	Nbhd. Adj	Notes	Location Adjustment	Adj Unit P	Land Value	
2	1040	TWO FAMILY			0 SF	0.00	1.00000		1.00		1.000			0	0	
Total Card Land Units					0.00	AC	Parcel Total Land Area					0.94	Total Land Value			0

