

CURRENT OWNER				TOPO	UTILITIES	STRT / ROAD	LOCATION	CURRENT ASSESSMENT				
ESTRELLA HEATH & DANA					2 Public Water			Description	Code	Appraised	Assessed	1302 EDGARTOWN, MA
3 BOLD MEADOW CIR								RESIDENTL	1010	1,188,300	1,188,300	
EDGARTOWN MA 02539				SUPPLEMENTAL DATA				RES LND	1010		696,500	696,500
Alt Prcl ID PLN#/Rec Lot# Plan Notes Plan Notes Plan Notes				Restriction Hist Distrct Other Note UC-Misc 1 UC-Misc 2				Total		1,884,800	1,884,800	VISION
GIS ID M_277855_794064				Assoc Pid#								

RECORD OF OWNERSHIP				BK-VOL/PAGE	SALE DATE	Q/U	V/I	SALE PRICE	VC	PREVIOUS ASSESSMENTS (HISTORY)									
ESTRELLA HEATH & DANA				0992	0099	03-16-2004	Q	I	832,000	00	Year	Code	Assessed	Year	Code	Assessed	Year	Code	Assessed
LOTHROP SANDRA C & KRICKL				0672	0754	03-21-1996	Q	V	65,500	00	2023	1010	1,194,100	2022	1010	857,500	2021	1010	857,500
MCKAY JAMES J				0648	0806	01-26-1995	U	V	1	1A		1010	718,700		1010	718,700		1010	620,100
MCKAY ANNA B				0648	0804	01-26-1995	U	V	1	1A									
HOOVER PETER C TRS				0546	0203	09-24-1990	U	V	1	1B									
Total												1,912,800	Total		1,576,200	Total		1,477,600	

EXEMPTIONS				OTHER ASSESSMENTS				
Year	Code	Description	Amount	Code	Description	Number	Amount	Comm Int
Total			0.00					

ASSESSING NEIGHBORHOOD				
Nbhd	Nbhd Name	B	Tracing	Batch
0050				

NOTES			
VALUED AS AC			
LOT 43 BLD MDW CF 431			
NATURAL I/A			

APPRAISED VALUE SUMMARY			
Appraised Bldg. Value (Card)			1,188,300
Appraised Xf (B) Value (Bldg)			0
Appraised Ob (B) Value (Bldg)			0
Appraised Land Value (Bldg)			696,500
Special Land Value			0
Total Appraised Parcel Value			1,884,800
Valuation Method			C
Total Appraised Parcel Value			1,884,800

BUILDING PERMIT RECORD										VISIT / CHANGE HISTORY					
Permit Id	Issue Date	Type	Description	Amount	Insp Date	% Comp	Date Comp	Comments		Date	Id	Type	Is	Cd	Purpost/Result
99256	04-30-1999	AD	Addition	5,000	01-03-2000	100		DECK		09-28-2022	EH		6	01	Cyclical Reinspection
										06-02-2022	DM			11	Field Review
										05-18-2017	AU			11	Field Review
										11-15-2011	RK			11	Field Review
										04-30-2004	JB			01	Cyclical Reinspection
										02-03-2000	RB			12	Bldg Permit/Measur/New C
										06-28-1988					

LAND LINE VALUATION SECTION																
B	Use Code	Description	Zone	Land Type	Land Units	Unit Price	Size Adj	Site Index	Cond.	Nbhd.	Nbhd. Adj	Notes	Location Adjustment	Adj Unit P	Land Value	
1	1010	SINGL FAM M-0	R60		39,309 SF	9.84	1.00000	5	1.00	0050	1.800			17.72	696,500	
Total Card Land Units					0.90	AC	Parcel Total Land Area					0.90	Total Land Value			696,500

CONSTRUCTION DETAIL			CONSTRUCTION DETAIL (CONTINUED)		
Element	Cd	Description	Element	Cd	Description
Style:	07	Standard Plus			
Model	01	Residential			
Grade:	05	Average +20			
Stories:	2				
Occupancy	1				
Exterior Wall 1	14	Wood Shingle			
Exterior Wall 2					
Roof Structure:	03	Gable/Hip			
Roof Cover	03	Asph/F Gls/Cmp			
Interior Wall 1	05	Drywall/Sheet			
Interior Wall 2					
Interior Flr 1	12	Hardwood			
Interior Flr 2	14	Carpet			
Heat Fuel	03	Gas			
Heat Type:	04	Forced Air-Duc			
AC Type:	03	Central			
Total Bedrooms	03	3 Bedrooms			
Total Bthrms:	2				
Total Half Baths	1				
Total Xtra Fixtrs					
Total Rooms:	6				
Bath Style:	02	Average			
Kitchen Style:	02	Modern			
			CONDO DATA		
Parcel Id			C	Owne 0.0	
			B	S	
Adjust Type	Code	Description	Factor%		
Condo Flr					
Condo Unit					
			COST / MARKET VALUATION		
Building Value New		1,398,009			
Year Built		1996			
Effective Year Built		2007			
Depreciation Code		A			
Remodel Rating					
Year Remodeled					
Depreciation %		15			
Functional Obsol		0			
External Obsol		0			
Trend Factor		1			
Condition					
Condition %					
Percent Good		85			
Cns Sect Rcnld		1,188,300			
Dep % Ovr					
Dep Ovr Comment					
Misc Imp Ovr					
Misc Imp Ovr Comment					
Cost to Cure Ovr					
Cost to Cure Ovr Comment					

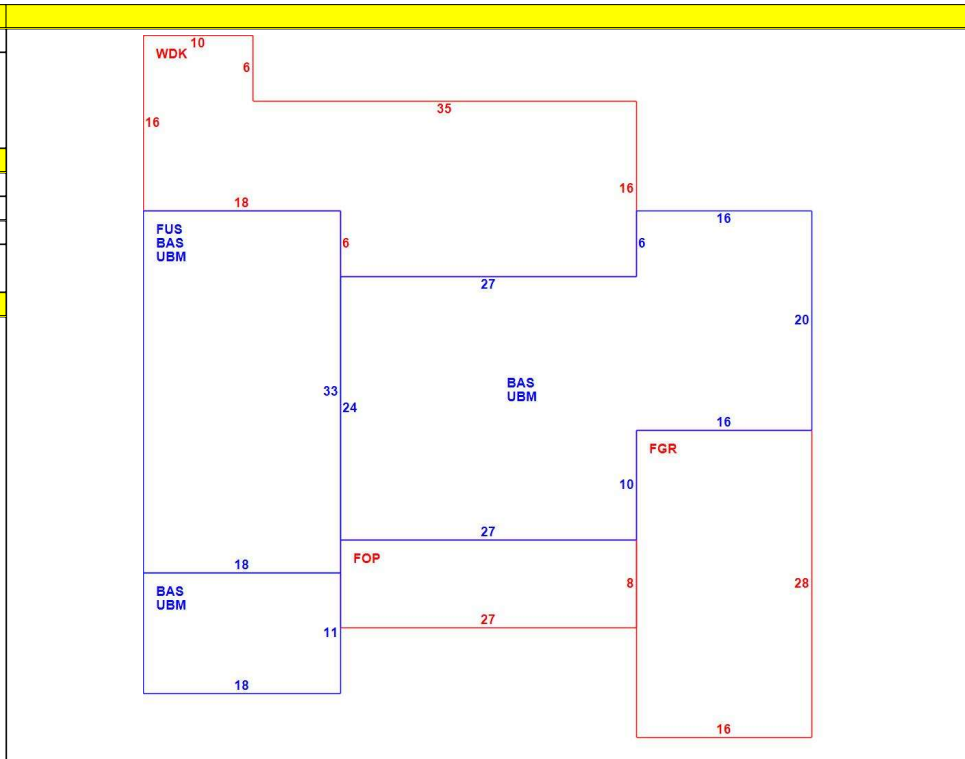

OB - OUTBUILDING & YARD ITEMS(L) / XF - BUILDING EXTRA FEATURES(B)										
Code	Description	L/B	Units	Unit Price	Yr Blt	Cond. Cd	% Gd	Grade	Grade Adj.	Appr. Value

BUILDING SUB-AREA SUMMARY SECTION							
Code	Description	Living Area	Floor Area	Eff Area	Unit Cost	Undeprec Value	
BAS	First Floor	1,760	1,760	1,760	463.78	816,246	
FGR	Garage	0	448	179	185.30	83,016	
FOP	Porch, Open, Finished	0	216	43	92.33	19,942	
FUS	Upper Story, Finished	594	594	594	463.78	275,483	
UBM	Basement, Unfinished	0	1,760	352	92.76	163,249	
WDK	Deck, Wood	0	672	67	46.24	31,073	
Ttl Gross Liv / Lease Area		2,354	5,450	2,995		1,389,009	

