

CURRENT OWNER		TOPO	UTILITIES	STRT / ROAD	LOCATION	CURRENT ASSESSMENT				
LUTSCHAUNIG ARTHUR & SWANSON DENISE 50 BAKER HILL DR			2 Public Water			Description	Code	Appraised	Assessed	1302 EDGARTOWN, MA
			3 Public Sewer			RESIDENTL RES LND	1010 1010	1,926,500 572,400	1,926,500 572,400	
HINGHAM MA 02043		SUPPLEMENTAL DATA				Total		2,498,900	2,498,900	VISION
		Alt Prcl ID PLN#/Rec Lot# Plan Notes Plan Notes Plan Notes GIS ID M_280272_792680	Restriction Hist Distrct Other Note UC-Misc 1 UC-Misc 2 Assoc Pid#							

RECORD OF OWNERSHIP		BK-VOL/PAGE	SALE DATE	Q/U	V/I	SALE PRICE	VC	PREVIOUS ASSESSMENTS (HISTORY)								
GUBITOSI JAMES E	0085	0031	06-30-2023	Q	I	2,825,000	00	Year	Code	Assessed	Year	Code	Assessed V	Year	Code	Assessed
LUTSCHAUNIG ARTHUR & ODOHERTY CONSTANTINE B	0070	0115	10-22-2010	Q	I	1,125,000	00	2023	1010	1,861,600	2022	1010	1,191,100	2021	1010	1,320,800
LARSON WARREN L	0069	0177	12-16-2009	U	V	325,000	1P		1010	590,800		1010	590,500		1010	509,400
LARSON WARREN L &	0066	0142	04-06-2007	U	V	1	1A									
	0057	0147	03-20-2000	U	V	1	1A	Total		2,452,400	Total		1,781,600	Total		1,830,200

EXEMPTIONS			OTHER ASSESSMENTS					
Year	Code	Description	Amount	Code	Description	Number	Amount	Comm Int
		Total	0.00					

ASSESSING NEIGHBORHOOD				
Nbhd	Nbhd Name	B	Tracing	Batch
0040				

APPRAISED VALUE SUMMARY	
Appraised Bldg. Value (Card)	1,923,900
Appraised Xf (B) Value (Bldg)	1,900
Appraised Ob (B) Value (Bldg)	700
Appraised Land Value (Bldg)	572,400
Special Land Value	0
Total Appraised Parcel Value	2,498,900
Valuation Method	C
Total Appraised Parcel Value	2,498,900

BUILDING PERMIT RECORD							VISIT / CHANGE HISTORY							
Permit Id	Issue Date	Type	Description	Amount	Insp Date	% Comp	Date Comp	Comments	Date	Id	Type	Is	Cd	Purpost/Result
2024-209	10-12-2023	RN	Res New Cons			0		BUILD 16X33 POOL	05-18-2022	LS			11	Field Review
2019-217	10-19-2018	RA	Res Add/Alter	75,000		0		FINISH BASEMENT	08-12-2019	EP			01	Cyclical Reinspection
217-2019	09-21-2010	CO	CO ISSUED			0		SFR	05-19-2017	DM			11	Field Review
123-2010	09-21-2010	CO	CO ISSUED					SFR/GARAGE	02-07-2011	EP			00	Measur+Listed
2010-123	12-11-2009	RN	Res New Cons					SFR/GARAGE	11-18-2010	EP			01	Cyclical Reinspection
									05-17-2010	EP			12	Bldg Permit/Measur/New C
									10-19-1978					

LAND LINE VALUATION SECTION															
B	Use Code	Description	Zone	Land Type	Land Units	Unit Price	Size Adj	Site Index	Cond.	Nbhd.	Nbhd. Adj	Notes	Location Adjustment	Adj Unit P	Land Value
1	1010	SINGL FAM M-0	R20		21,780	SF	14.57	1.00000	4	1.00	0050	1.800		26.23	571,200
1	1010	SINGL FAM M-0	R20		0.020	AC	34,000.00	1.00000	0	1.00	0050	1.800		61,200	1,200
Total Card Land Units					0.52	AC	Parcel Total Land Area					0.52	Total Land Value		572,400

CONSTRUCTION DETAIL			CONSTRUCTION DETAIL (CONTINUED)		
Element	Cd	Description	Element	Cd	Description
Style:	06	Custom			
Model	01	Residential			
Grade:	05	Average +20			
Stories:	2				
Occupancy	1				
Exterior Wall 1	14	Wood Shingle			
Exterior Wall 2					
Roof Structure:	03	Gable/Hip			
Roof Cover	03	Asph/F GlS/Cmp			
Interior Wall 1	05	Drywall/Sheet			
Interior Wall 2					
Interior Flr 1	12	Hardwood			
Interior Flr 2					
Heat Fuel	03	Gas			
Heat Type:	04	Forced Air-Duc			
AC Type:	03	Central			
Total Bedrooms	04	4 Bedrooms			
Total Bthrms:	4				
Total Half Baths	1				
Total Xtra Fixtrs					
Total Rooms:	8				
Bath Style:	02	Average			
Kitchen Style:	02	Modern			
CONDO DATA					
Parcel Id		C	Owne	0.0	
Adjust Type	Code	Description	Factor%		
Condo Flr					
Condo Unit					
COST / MARKET VALUATION					
Building Value New			1,983,411		
Year Built			2010		
Effective Year Built			2019		
Depreciation Code			G		
Remodel Rating					
Year Remodeled					
Depreciation %			3		
Functional Obsol			0		
External Obsol			0		
Trend Factor			1		
Condition					
Condition %					
Percent Good			97		
Cns Sect Rcnd			1,923,900		
Dep % Ovr					
Dep Ovr Comment					
Misc Imp Ovr					
Misc Imp Ovr Comment					
Cost to Cure Ovr					
Cost to Cure Ovr Comment					

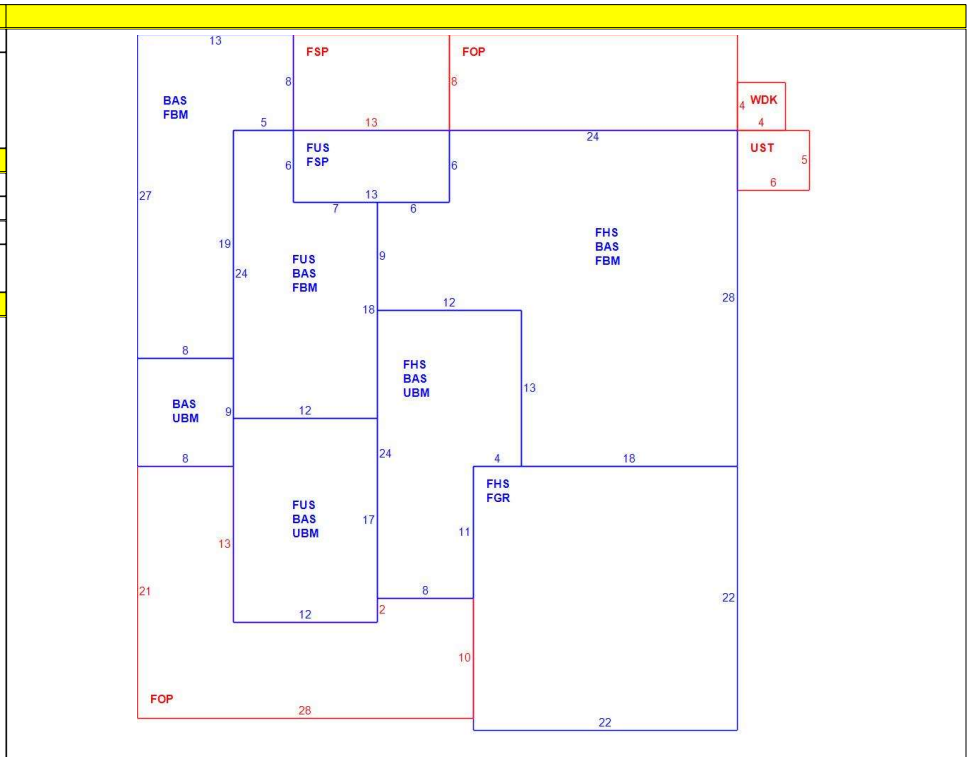

OB - OUTBUILDING & YARD ITEMS(L) / XF - BUILDING EXTRA FEATURES(B)										
Code	Description	L/B	Units	Unit Price	Yr Blt	Cond. Cd	% Gd	Grade	Grade Adj.	Appr. Value
FPL	MTL-WD C/PI	B	1	2000.00	2013		97		0.00	1,900
ODP	OUTDOOR PL	L	1	700.00	2010		100		0.00	700

BUILDING SUB-AREA SUMMARY SECTION						
Code	Description	Living Area	Floor Area	Eff Area	Unit Cost	Undeprec Value
BAS	First Floor	1,670	1,670	1,670	506.95	846,610
FBM	Basement, Finished	0	1,150	518	228.35	262,601
FGR	Garage	0	484	194	203.20	98,349
FHS	Half Story, Finished	688	1,376	688	253.48	348,783
FOP	Porch, Open, Finished	0	536	107	101.20	54,244
FSP	Porch, Screen, Finished	0	182	46	128.13	23,320
FUS	Upper Story, Finished	528	528	528	506.95	267,671
UBM	Basement, Unfinished	0	520	104	101.39	52,723
UST	Utility, Storage, Unfinished	0	30	14	236.58	7,097
WDK	Deck, Wood	0	16	2	63.37	1,014
Ttl Gross Liv / Lease Area		2,886	6,492	3,871		1,962,412

