

| CURRENT OWNER | | TOPO | UTILITIES | STRT / ROAD | LOCATION | CURRENT ASSESSMENT | | | | 1302 EDGARTOWN, MA | | | | | | |
|---|------------|---------------|----------------------------------|-------------|-------------|---|------------------------|------------|--------------------------------|-----------------------|-----------|-----------|---------------------|-----------------------|------------|---------|
| KANIA SUSAN L KANIA ROBERT H 231 WINDING RIDGE SOUTHINGTON CT 06489 | | | 2 Public Water 3 Public Sewer | | | Description | Code | Appraised | Assessed | | | | | | | |
| | | | | | | RESIDENTL | 1010 | 785,200 | 785,200 | VISION | | | | | | |
| | | | | | | RES LND | 1010 | 825,100 | 825,100 | | | | | | | |
| SUPPLEMENTAL DATA | | | | | | Total | | 1,610,300 | 1,610,300 | | | | | | | |
| Alt Prcl ID PLN#/Rec Lot# Plan Notes Plan Notes Plan Notes GIS ID M_281411_792568 | | | | | | Restriction Hist Distrct Other Note UC-Misc 1 UC-Misc 2 Assoc Pid# | | | | | | | | | | |
| RECORD OF OWNERSHIP | | | BK-VOL/PAGE | SALE DATE | Q/U | V/I | SALE PRICE | VC | PREVIOUS ASSESSMENTS (HISTORY) | | | | | | | |
| KANIA SUSAN L | | | 1608 143 | 12-21-2021 | U | I | 10 | 1A | Year | Code | Assessed | Year | Code | Assessed | | |
| KANIA ROBERT & SUSAN | | | 1191 0893 | 09-11-2009 | Q | I | 820,000 | 00 | 2023 | 1010 | 739,700 | 2022 | 1010 | 466,900 | | |
| DICAPUA RICHARD A & BRAINERD | | | 0648 0871 | 01-27-1995 | Q | I | 204,000 | 00 | | 1010 | 831,300 | 2021 | 1010 | 728,400 | | |
| DANIELS RICHARD C | | | 092P 0051 | 08-05-1992 | U | I | 1 | | | | | | | | | |
| DANIELS RICHARD C | | | 0321 0257 | 10-24-1974 | | | 0 | | | | | | | | | |
| | | | | | | Total | | 1,571,000 | Total | 1,298,200 | Total | 1,161,200 | | | | |
| EXEMPTIONS | | | OTHER ASSESSMENTS | | | This signature acknowledges a visit by a Data Collector or Assessor | | | | | | | | | | |
| Year | Code | Description | Amount | Code | Description | Number | Amount | Comm Int | | | | | | | | |
| | | | Total | 0.00 | | | | | | | | | | | | |
| ASSESSING NEIGHBORHOOD | | | | | | APPRAISED VALUE SUMMARY | | | | | | | | | | |
| Nbhd | Nbhd Name | B | | Tracing | | Batch | | | | | | | | | | |
| KF5 | | | | | | | | | | | | | | | | |
| NOTES | | | | | | Appraised Bldg. Value (Card) 780,300 | | | | | | | | | | |
| LOT 11 KITTS FLD CF 42 | | | | | | Appraised Xf (B) Value (Bldg) 2,400 | | | | | | | | | | |
| HOT TUB ON DECK | | | | | | Appraised Ob (B) Value (Bldg) 2,500 | | | | | | | | | | |
| REAR DORMER | | | | | | Appraised Land Value (Bldg) 825,100 | | | | | | | | | | |
| PROP HEATER | | | | | | Special Land Value 0 | | | | | | | | | | |
| | | | | | | Total Appraised Parcel Value 1,610,300 | | | | | | | | | | |
| | | | | | | Valuation Method C | | | | | | | | | | |
| | | | | | | Total Appraised Parcel Value 1,610,300 | | | | | | | | | | |
| BUILDING PERMIT RECORD | | | | | | VISIT / CHANGE HISTORY | | | | | | | | | | |
| Permit Id | Issue Date | Type | Description | Amount | Insp Date | % Comp | Date Comp | Comments | Date | Id | Type | Is | Cd | Purpost/Result | | |
| 2023-525 | 04-06-2023 | RA | Res Add/Alter | 6,434 | | | | INSULATION | 10-17-2022 | EH | | 6 | 01 | Cyclical Reinspection | | |
| | | | | | | | | | 05-24-2022 | LS | | | 11 | Field Review | | |
| | | | | | | | | | 05-16-2017 | MM | | | 11 | Field Review | | |
| | | | | | | | | | 06-24-2014 | SER | | | 11 | Field Review | | |
| | | | | | | | | | 10-26-2009 | EP | | | 01 | Cyclical Reinspection | | |
| | | | | | | | | | 02-02-2004 | CR | | | 01 | Cyclical Reinspection | | |
| | | | | | | | | | 09-18-1978 | | | | | | | |
| LAND LINE VALUATION SECTION | | | | | | | | | | | | | | | | |
| B | Use Code | Description | Zone | Land Type | Land Units | Unit Price | Size Adj | Site Index | Cond. | Nbhd. | Nbhd. Adj | Notes | Location Adjustment | Adj Unit P | Land Value | |
| 1 | 1010 | SINGL FAM M-0 | R20 | | 21,780 SF | 14.57 | 1.00000 | 5 | 1.00 | 0060 | 2.600 | | | 37.88 | 825,100 | |
| Total Card Land Units | | | | | 0.50 | AC | Parcel Total Land Area | | | | | 0.50 | Total Land Value | | | 825,100 |

| CONSTRUCTION DETAIL | | | CONSTRUCTION DETAIL (CONTINUED) | | |
|--------------------------------|------|----------------|---------------------------------|-----|-------------|
| Element | Cd | Description | Element | Cd | Description |
| Style: | 04 | Cape Cod | | | |
| Model | 01 | Residential | | | |
| Grade: | 05 | Ave/Good | | | |
| Stories: | 1.75 | | | | |
| Occupancy | 1 | | | | |
| Exterior Wall 1 | 14 | Wood Shingle | | | |
| Exterior Wall 2 | | | | | |
| Roof Structure: | 03 | Gable/Hip | | | |
| Roof Cover | 03 | Asph/F Gls/Cmp | | | |
| Interior Wall 1 | 05 | Drywall/Sheet | | | |
| Interior Wall 2 | | | | | |
| Interior Flr 1 | 14 | Carpet | | | |
| Interior Flr 2 | 12 | Hardwood | | | |
| Heat Fuel | 04 | Electric | | | |
| Heat Type: | 07 | Electr Basebrd | | | |
| AC Type: | 01 | None | | | |
| Total Bedrooms | 03 | 3 Bedrooms | | | |
| Total Bthrms: | 2 | | | | |
| Total Half Baths | 1 | | | | |
| Total Xtra Fixtrs | | | | | |
| Total Rooms: | 0 | | | | |
| Bath Style: | 01 | Old Style | | | |
| Kitchen Style: | 01 | Old Style | | | |
| CONDO DATA | | | | | |
| Parcel Id | | C | Owne | 0.0 | |
| Adjust Type | | | B | S | |
| Condo Flr | | | | | |
| Condo Unit | | | | | |
| COST / MARKET VALUATION | | | | | |
| Building Value New | | | 975,375 | | |
| Year Built | | | 1973 | | |
| Effective Year Built | | | 2002 | | |
| Depreciation Code | | | G | | |
| Remodel Rating | | | | | |
| Year Remodeled | | | | | |
| Depreciation % | | | 20 | | |
| Functional Obsol | | | 0 | | |
| External Obsol | | | 0 | | |
| Trend Factor | | | 1 | | |
| Condition | | | | | |
| Condition % | | | | | |
| Percent Good | | | 80 | | |
| Cns Sect Rcnd | | | 780,300 | | |
| Dep % Ovr | | | | | |
| Dep Ovr Comment | | | | | |
| Misc Imp Ovr | | | | | |
| Misc Imp Ovr Comment | | | | | |
| Cost to Cure Ovr | | | | | |
| Cost to Cure Ovr Comment | | | | | |

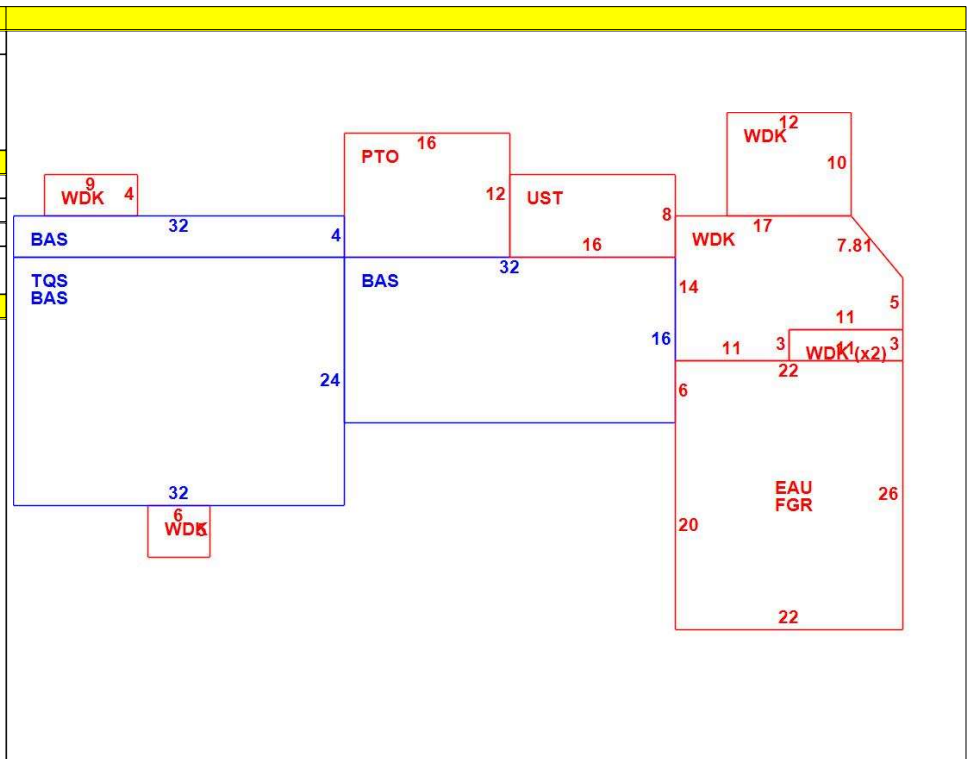

OB - OUTBUILDING & YARD ITEMS(L) / XF - BUILDING EXTRA FEATURES(B)

| Code | Description | L/B | Units | Unit Price | Yr Blt | Cond. Cd | % Gd | Grade | Grade Adj. | Appr. Value |
|------|-------------|-----|-------|------------|--------|----------|------|-------|------------|-------------|
| FPL1 | FPL MSNRY 1 | B | 1 | 3000.00 | 1996 | | 80 | | 0.00 | 2,400 |
| SHD2 | W/LIGHTS ET | L | 140 | 18.00 | 2004 | | 70 | | 0.00 | 1,800 |
| ODP | OUTDOOR PL | L | 1 | 700.00 | 2008 | | 100 | | 0.00 | 700 |

BUILDING SUB-AREA SUMMARY SECTION

| Code | Description | Living Area | Floor Area | Eff Area | Unit Cost | Undeprec Value |
|----------------------------|------------------------------|-------------|------------|----------|-----------|----------------|
| BAS | First Floor | 1,408 | 1,408 | 1,408 | 389.04 | 547,768 |
| EAU | Attic, Expansion, Unfinished | 0 | 572 | 143 | 97.26 | 55,633 |
| FGR | Garage | 0 | 572 | 229 | 155.75 | 89,090 |
| PTO | Patio | 0 | 192 | 19 | 38.50 | 7,392 |
| TQS | Three Quarter Story | 576 | 768 | 576 | 291.78 | 224,087 |
| UST | Utility, Storage, Unfinished | 0 | 128 | 58 | 176.28 | 22,564 |
| WDK | Deck, Wood | 0 | 512 | 51 | 38.75 | 19,841 |
| Ttl Gross Liv / Lease Area | | 1,984 | 4,152 | 2,484 | | 966,375 |

