

| CURRENT OWNER | | | | TOPO | UTILITIES | STRT / ROAD | LOCATION | CURRENT ASSESSMENT | | | | |
|---|--|--|--|--|--------------|-------------|----------|--------------------|------|-----------|-----------|-----------------------|
| INNISFAIL LLC | | | | 2 | Public Water | | | Description | Code | Appraised | Assessed | 1302 EDGARTOWN, MA |
| 31 IRISH COVE RD | | | | | | | | RESIDENTL | 1010 | 1,270,900 | 1,270,900 | |
| SO BURLINGTON VT 05403 | | | | SUPPLEMENTAL DATA | | | | RES LND | 1010 | 847,200 | 847,200 | VISION |
| Alt Prcl ID PLN#/Rec Lot# Plan Notes Plan Notes Plan Notes | | | | Restriction Hist District Other Note UC-Misc 1 UC-Misc 2 | | | | Total | | 2,118,100 | 2,118,100 | |
| GIS ID M_281440_792459 | | | | Assoc Pid# | | | | | | | | |

| RECORD OF OWNERSHIP | | | | | | | BK-VOL/PAGE | SALE DATE | Q/U | V/I | SALE PRICE | VC | PREVIOUS ASSESSMENTS (HISTORY) | | | | | | | | | |
|---------------------|--|--|--|--|--|--|-------------|-----------|------------|-----|------------|---------|--------------------------------|------|-----------|-----------|------|-----------|----------|------|-----------|----------|
| INNISFAIL LLC | | | | | | | 1503 | 910 | 08-22-2019 | U | I | 1 | 1A | Year | Code | Assessed | Year | Code | Assessed | Year | Code | Assessed |
| POST ALLEN C TRS | | | | | | | 0807 | 0879 | 08-29-2000 | Q | V | 275,000 | 01 | 2023 | 1010 | 1,206,600 | 2022 | 1010 | 869,200 | 2021 | 1010 | 869,200 |
| WARD ROBIN LYNN | | | | | | | 0341 | 0240 | 12-30-1976 | U | V | 0 | | | 1010 | 854,700 | | 1010 | 848,500 | | 1010 | 745,000 |
| Total | | | | | | | | | | | | | Total | | 2,061,300 | Total | | 1,717,700 | Total | | 1,614,200 | |

| EXEMPTIONS | | | | OTHER ASSESSMENTS | | | | This signature acknowledges a visit by a Data Collector or Assessor | | | | | | | | | | | | |
|------------------------|-----------|-------------|--------|-------------------|-------------|--------|--------|---|--|--|--|-----------|--|--|--|--|--|--|--|--|
| Year | Code | Description | Amount | Code | Description | Number | Amount | Comm Int | | | | | | | | | | | | |
| Total | | | 0.00 | | | | | | | | | | | | | | | | | |
| ASSESSING NEIGHBORHOOD | | | | | | | | APPRAISED VALUE SUMMARY | | | | | | | | | | | | |
| Nbhd | Nbhd Name | | B | Tracing | | Batch | | Appraised Bldg. Value (Card) | | | | 1,267,000 | | | | | | | | |
| KF5 | | | | | | | | Appraised Xf (B) Value (Bldg) | | | | 3,200 | | | | | | | | |
| | | | | | | | | Appraised Ob (B) Value (Bldg) | | | | 700 | | | | | | | | |
| | | | | | | | | Appraised Land Value (Bldg) | | | | 847,200 | | | | | | | | |
| | | | | | | | | Special Land Value | | | | 0 | | | | | | | | |
| | | | | | | | | Total Appraised Parcel Value | | | | 2,118,100 | | | | | | | | |
| | | | | | | | | Valuation Method | | | | C | | | | | | | | |
| | | | | | | | | Total Appraised Parcel Value | | | | 2,118,100 | | | | | | | | |

| BUILDING PERMIT RECORD | | | | | | | | | | VISIT / CHANGE HISTORY | | | | | |
|------------------------|------------|------|---------------|--------|-----------|--------|-----------|----------|--|------------------------|-----|------|----|----|-----------------------|
| Permit Id | Issue Date | Type | Description | Amount | Insp Date | % Comp | Date Comp | Comments | | Date | Id | Type | Is | Cd | Purpost/Result |
| | 08-08-2001 | NC | New Construct | | | | | SFR | | 05-24-2022 | LS | | | 11 | Field Review |
| | | | | | | | | | | 12-31-2018 | EP | | | 01 | Cyclical Reinspection |
| | | | | | | | | | | 05-16-2017 | MM | | | 11 | Field Review |
| | | | | | | | | | | 06-24-2014 | SER | | | 11 | Field Review |
| | | | | | | | | | | 01-24-2003 | WP | | | 11 | Field Review |
| | | | | | | | | | | 09-18-1978 | | | | | |

| LAND LINE VALUATION SECTION | | | | | | | | | | | | | | | | |
|-----------------------------|----------|---------------|------|-----------|------------|------------|------------------------|------------|-------|-------|-----------|-------|------------------|---------------------|------------|------------|
| B | Use Code | Description | Zone | Land Type | Land Units | Unit Price | Size Adj | Site Index | Cond. | Nbhd. | Nbhd. Adj | Notes | | Location Adjustment | Adj Unit P | Land Value |
| 1 | 1010 | SINGL FAM M-0 | R20 | | 21,780 | SF | 14.57 | 1.00000 | 5 | 1.00 | 0060 | 2.600 | | | 37.88 | 825,100 |
| 1 | 1010 | SINGL FAM M-0 | R20 | | 0.250 | AC | 34,000.00 | 1.00000 | 0 | 1.00 | 0060 | 2.600 | | | 88,400 | 22,100 |
| Total Card Land Units | | | | | 0.75 | AC | Parcel Total Land Area | | | | | 0.75 | Total Land Value | | | 847,200 |

| CONSTRUCTION DETAIL | | | CONSTRUCTION DETAIL (CONTINUED) | | |
|--------------------------------|----|----------------|---------------------------------|---------|-------------|
| Element | Cd | Description | Element | Cd | Description |
| Style: | 07 | Standard Plus | | | |
| Model | 01 | Residential | | | |
| Grade: | 05 | Ave/Good | | | |
| Stories: | 1 | 1 Story | | | |
| Occupancy | | | | | |
| Exterior Wall 1 | 14 | Wood Shingle | | | |
| Exterior Wall 2 | | | | | |
| Roof Structure: | 03 | Gable/Hip | | | |
| Roof Cover | 03 | Asph/F Gls/Cmp | | | |
| Interior Wall 1 | 05 | Drywall/Sheet | | | |
| Interior Wall 2 | | | | | |
| Interior Flr 1 | 12 | Hardwood | | | |
| Interior Flr 2 | 14 | Carpet | | | |
| Heat Fuel | 03 | Gas | | | |
| Heat Type: | 04 | Forced Air-Duc | | | |
| AC Type: | 02 | Heat Pump | | | |
| Total Bedrooms | 03 | 3 Bedrooms | | | |
| Total Bthrms: | 3 | | | | |
| Total Half Baths | 1 | | | | |
| Total Xtra Fixtrs | | | | | |
| Total Rooms: | | | | | |
| Bath Style: | 02 | Average | | | |
| Kitchen Style: | 02 | Modern | | | |
| | | | CONDO DATA | | |
| Parcel Id | | | C | Owne | 0.0 |
| Adjust Type | | Code | Description | Factor% | |
| Condo Flr | | | | | |
| Condo Unit | | | | | |
| COST / MARKET VALUATION | | | | | |
| Building Value New | | | 1,407,818 | | |
| Year Built | | | 2001 | | |
| Effective Year Built | | | 2012 | | |
| Depreciation Code | | | A | | |
| Remodel Rating | | | | | |
| Year Remodeled | | | | | |
| Depreciation % | | | 10 | | |
| Functional Obsol | | | 0 | | |
| External Obsol | | | 0 | | |
| Trend Factor | | | 1 | | |
| Condition | | | | | |
| Condition % | | | | | |
| Percent Good | | | 90 | | |
| Cns Sect Rcnd | | | 1,267,000 | | |
| Dep % Ovr | | | | | |
| Dep Ovr Comment | | | | | |
| Misc Imp Ovr | | | | | |
| Misc Imp Ovr Comment | | | | | |
| Cost to Cure Ovr | | | | | |
| Cost to Cure Ovr Comment | | | | | |

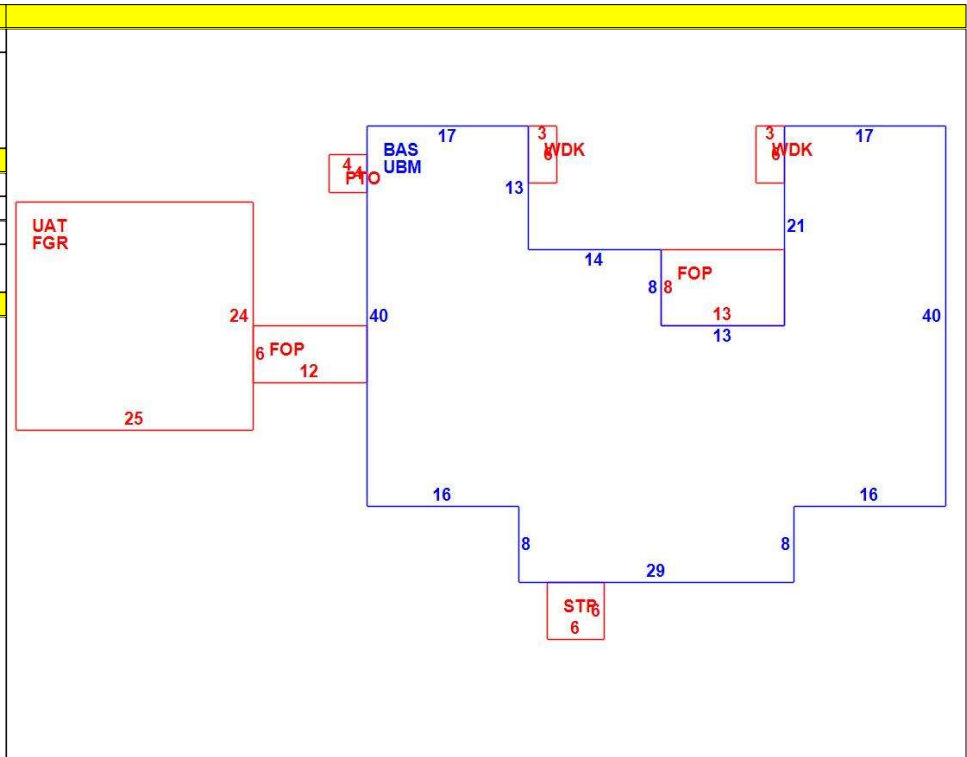

| OB - OUTBUILDING & YARD ITEMS(L) / XF - BUILDING EXTRA FEATURES(B) | | | | | | | | | | |
|--|-------------|-----|-------|------------|--------|----------|------|-------|------------|-------------|
| Code | Description | L/B | Units | Unit Price | Yr Blt | Cond. Cd | % Gd | Grade | Grade Adj. | Appr. Value |
| FPL2 | FPL MSNRY 1 | B | 1 | 3500.00 | 2006 | | 90 | | 0.00 | 3,200 |
| ODS | OUTDOOR S | L | 1 | 700.00 | | | 100 | | 0.00 | 700 |

| BUILDING SUB-AREA SUMMARY SECTION | | | | | | |
|-----------------------------------|-----------------------|-------------|------------|----------|-----------|----------------|
| Code | Description | Living Area | Floor Area | Eff Area | Unit Cost | Undeprec Value |
| BAS | First Floor | 2,217 | 2,217 | 2,217 | 463.50 | 1,027,580 |
| FGR | Garage | 0 | 600 | 240 | 185.40 | 111,240 |
| FOP | Porch, Open, Finished | 0 | 176 | 35 | 92.17 | 16,223 |
| PTO | Patio | 0 | 16 | 2 | 57.94 | 927 |
| STP | Stoop | 0 | 36 | 4 | 51.50 | 1,854 |
| UAT | Attic, Unfinished | 0 | 600 | 60 | 46.35 | 27,810 |
| UBM | Basement, Unfinished | 0 | 2,217 | 443 | 92.62 | 205,331 |
| WDK | Deck, Wood | 0 | 36 | 4 | 51.50 | 1,854 |
| Ttl Gross Liv / Lease Area | | 2,217 | 5,898 | 3,005 | | 1,392,819 |

