

| CURRENT OWNER   |  |  | TOPO  | UTILITIES | STRT / ROAD | LOCATION | CURRENT ASSESSMENT   |              |                          |                          |                       |
|---|--|--|---|-----------|-------------|----------|----------------------|--------------|--------------------------|--------------------------|-----------------------|
| REYNOLDS JAMES F--TRS<br>CATALINA ISLAND NOMINEE TRUST<br>PO BOX 962049   |  |  |   |           |             |          | Description          | Code         | Appraised                | Assessed                 | 1302<br>EDGARTOWN, MA |
| BOSTON MA 02196   |  |  |   |           |             |          | RESIDENTL<br>RES LND | 1090<br>1090 | 11,470,400<br>15,667,800 | 11,470,400<br>15,667,800 |                       |
| SUPPLEMENTAL DATA   |  |  |   |           |             |          |                      |              |                          |                          |                       |
| Alt Prcl ID<br>PLN#/Rec<br>Lot#<br>Plan Notes<br>Plan Notes<br>Plan Notes |  |  | Restriction<br>Hist Distrct<br>Other Note<br>UC-Misc 1<br>UC-Misc 2 |           |             |          |                      |              |                          |                          |                       |
| GIS ID M_283001_792444  |  |  | Assoc Pid#  |           |             |          |                      |              |                          |                          |                       |
|   |  |  |   |           |             |          | Total                |              | 27,138,200               | 27,138,200               |                       |

**VISION**

| RECORD OF OWNERSHIP      |  |  |  |  |  |  | BK-VOL/PAGE | SALE DATE | Q/U        | V/I | SALE PRICE | VC         | PREVIOUS ASSESSMENTS (HISTORY) |      |            |            |       |      |            |
|--------------------------|--|--|--|--|--|--|-------------|-----------|------------|-----|------------|------------|--------------------------------|------|------------|------------|-------|------|------------|
| REYNOLDS JAMES F--TRS    |  |  |  |  |  |  | 0078        | 0059      | 06-30-2017 | U   | I          | 20,500,000 | 1V                             | Year | Code       | Assessed   | Year  | Code | Assessed   |
| MV OCEAN LLC             |  |  |  |  |  |  | 0070        | 0043      | 08-16-2010 | U   | I          | 17,375,000 | 1V                             | 2023 | 1090       | 8,906,200  | 2022  | 1090 | 6,762,800  |
| REYNOLDS JAMES F--TRS    |  |  |  |  |  |  | 0064        | 0341      | 02-16-2006 | U   | I          | 25,175,000 | 1                              |      | 1090       | 15,177,500 |       | 1090 | 14,036,346 |
| HEDLEY DAVID V & MICHELE |  |  |  |  |  |  | 0041        | 0259      | 03-06-1990 | U   | I          | 1          | 1                              |      |            |            |       |      |            |
| HEDLEY DAVID V & MICHELE |  |  |  |  |  |  | 0040        | 0225      | 01-20-1989 | U   | I          | 2,400,000  | 1                              |      |            |            |       |      |            |
|                          |  |  |  |  |  |  | Total       |           |            |     | 24,083,700 |            | Total                          |      | 20,799,146 |            | Total |      | 20,241,360 |

| EXEMPTIONS |      |             |        | OTHER ASSESSMENTS |             |        |        | APPRAISED VALUE SUMMARY              |   |  |  |  |
|------------|------|-------------|--------|-------------------|-------------|--------|--------|--------------------------------------|---|--|--|--|
| Year       | Code | Description | Amount | Code              | Description | Number | Amount | Comm Int                             | This signature acknowledges a visit by a Data Collector or Assessor |  |  |  |
|            |      |             |        |                   |             |        |        |                                      | Appraised Bldg. Value (Card) 11,159,800                             |  |  |  |
| Total      |      |             | 0.00   |                   |             |        |        | Appraised Xf (B) Value (Bldg) 11,500 |   |  |  |  |

| ASSESSING NEIGHBORHOOD |           |   |         |
|------------------------|-----------|---|---------|
| Nbhd                   | Nbhd Name | B | Tracing |
| 0090                   |           |   |         |

| NOTES   |  |  |  |  |  |  |  |            |  |  |  |
|---|--|--|--|--|--|--|--|------------|--|--|--|
| LOT #73 OCEAN VIEW CLIFFS<br>CAB=LIGHTHOUSE<br>2006 SALE 3 PCLS WITH 29-146 &29-154<br>2010 SALE INCL BOAT & FURN VALUED 625K |  |  |  |  |  |  |  |            |  |  |  |
| Total Appraised Parcel Value  |  |  |  |  |  |  |  | 27,138,200 |  |  |  |

| BUILDING PERMIT RECORD |            |      |              |           |           |        | VISIT / CHANGE HISTORY |                         |            |     |      |    |    |                       |
|------------------------|------------|------|--------------|-----------|-----------|--------|------------------------|-------------------------|------------|-----|------|----|----|-----------------------|
| Permit Id              | Issue Date | Type | Description  | Amount    | Insp Date | % Comp | Date Comp              | Comments                | Date       | Id  | Type | Is | Cd | Purpost/Result        |
| 2022-906               | 07-27-2022 | SOLR | Solar Panels |           |           | 0      |                        |                         | 08-31-2023 | EH  |      |    | 00 | Measur+Listed         |
| 2022-244               | 11-08-2021 | RN   | Res New Cons | 300,000   |           |        |                        | SPL                     | 05-24-2022 | LS  |      |    | 11 | Field Review          |
| 2021-360               | 12-09-2020 | RN   |              | 1,000,000 |           |        |                        | DEMO/BLD GARAGE         | 11-04-2019 | EP  |      |    | 01 | Cyclical Reinspection |
| 2021-332               | 12-02-2020 | RN   |              | 1,500,000 |           | 0      |                        | BLD GUEST/POOL HOUSES   | 05-16-2017 | MM  |      |    | 11 | Field Review          |
| 2021-69                | 09-03-2020 | RN   |              | 6,000,000 |           | 0      |                        | DEMO EXISTING SFR AND B | 07-30-2014 | EP  |      |    | 01 | Cyclical Reinspection |
| 2021-45                | 08-06-2020 | DE   |              | 7,500     |           | 0      |                        | DEMO POOL               | 06-24-2014 | SER |      |    | 11 | Field Review          |
| 2021-44                | 08-06-2020 | DE   |              | 5,000     |           | 0      |                        | DEMO POOL HOUSE         | 04-17-2012 | EP  |      |    | 11 | Field Review          |

| LAND LINE VALUATION SECTION |          |             |      |           |            |              |                        |            |       |       |           |       |                     |            |            |
|-----------------------------|----------|-------------|------|-----------|------------|--------------|------------------------|------------|-------|-------|-----------|-------|---------------------|------------|------------|
| B                           | Use Code | Description | Zone | Land Type | Land Units | Unit Price   | Size Adj               | Site Index | Cond. | Nbhd. | Nbhd. Adj | Notes | Location Adjustment | Adj Unit P | Land Value |
| 1                           | 1090     | MULTI HSES  | R60  |           | 65,340     | SF 6.54      | 1.00000                | 7          | 1.00  | 0090  | 4.900     |       | W65                 | 208.3      | 13,610,300 |
| 1                           | 1090     | MULTI HSES  | R60  |           | 300        | FF 0.01      | 1.00000                | 0          | 1.00  | 0090  | 4.900     |       |                     | 0.05       | 0          |
| 1                           | 1090     | MULTI HSES  | R60  |           | 1.900      | AC 34,000.00 | 1.00000                | 0          | 1.00  | 0090  | 4.900     |       | W65                 | 1,082,900  | 2,057,500  |
| Total Card Land Units       |          |             |      |           | 3.40       | AC           | Parcel Total Land Area |            |       |       |           | 3.40  | Total Land Value    |            | 15,667,800 |

| CONSTRUCTION DETAIL            |    |                | CONSTRUCTION DETAIL (CONTINUED) |           |             |
|--------------------------------|----|----------------|---------------------------------|-----------|-------------|
| Element                        | Cd | Description    | Element                         | Cd        | Description |
| Style:                         | 11 | Estate         |                                 |           |             |
| Model                          | 01 | Residential    |                                 |           |             |
| Grade:                         | 10 | Superior       |                                 |           |             |
| Stories:                       | 2  | 2 Stories      |                                 |           |             |
| Occupancy                      | 1  |                |                                 |           |             |
| Exterior Wall 1                | 10 | Above Average  |                                 |           |             |
| Exterior Wall 2                |    |                |                                 |           |             |
| Roof Structure:                | 05 | Salt Box       |                                 |           |             |
| Roof Cover                     | 10 | Wood Shingle   |                                 |           |             |
| Interior Wall 1                | 03 | Plastered      |                                 |           |             |
| Interior Wall 2                | 06 | Cust Wd Panel  |                                 |           |             |
| Interior Flr 1                 | 12 | Hardwood       |                                 |           |             |
| Interior Flr 2                 | 18 | Slate          |                                 |           |             |
| Heat Fuel                      | 03 | Gas            |                                 |           |             |
| Heat Type:                     | 04 | Forced Air-Duc |                                 |           |             |
| AC Type:                       | 03 | Central        |                                 |           |             |
| Total Bedrooms                 | 04 | 4 Bedrooms     |                                 |           |             |
| Total Bthrms:                  | 3  |                |                                 |           |             |
| Total Half Baths               | 1  |                |                                 |           |             |
| Total Xtra Fixtrs              | 6  |                |                                 |           |             |
| Total Rooms:                   |    | 10 Rooms       |                                 |           |             |
| Bath Style:                    | 02 | Average        |                                 |           |             |
| Kitchen Style:                 | 02 | Modern         |                                 |           |             |
| <b>CONDO DATA</b>              |    |                |                                 |           |             |
| Parcel Id                      |    |                | C                               | Ownr      | 0.0         |
| Adjust Type                    |    | Code           | Description                     | Factor%   |             |
| Condo Flr                      |    |                |                                 | B         | S           |
| Condo Unit                     |    |                |                                 |           |             |
| <b>COST / MARKET VALUATION</b> |    |                |                                 |           |             |
| Building Value New             |    |                |                                 | 8,145,684 |             |
| Year Built                     |    |                |                                 | 2023      |             |
| Effective Year Built           |    |                |                                 | 2022      |             |
| Depreciation Code              |    |                |                                 | A         |             |
| Remodel Rating                 |    |                |                                 |           |             |
| Year Remodeled                 |    |                |                                 |           |             |
| Depreciation %                 |    |                |                                 | 0         |             |
| Functional Obsol               |    |                |                                 | 0         |             |
| External Obsol                 |    |                |                                 | 0         |             |
| Trend Factor                   |    |                |                                 | 1         |             |
| Condition                      |    |                |                                 |           |             |
| Condition %                    |    |                |                                 |           |             |
| Percent Good                   |    |                |                                 | 100       |             |
| Cns Sect Rcnd                  |    |                |                                 | 8,145,700 |             |
| Dep % Ovr                      |    |                |                                 |           |             |
| Dep Ovr Comment                |    |                |                                 |           |             |
| Misc Imp Ovr                   |    |                |                                 |           |             |
| Misc Imp Ovr Comment           |    |                |                                 |           |             |
| Cost to Cure Ovr               |    |                |                                 |           |             |
| Cost to Cure Ovr Comment       |    |                |                                 |           |             |

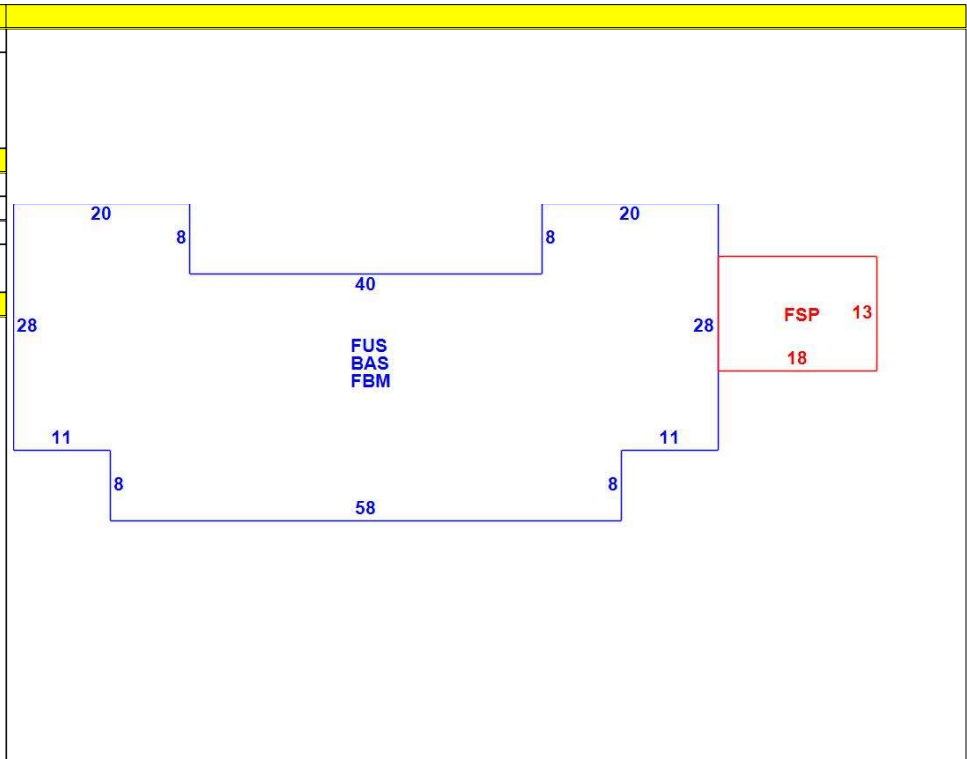

| OB - OUTBUILDING & YARD ITEMS(L) / XF - BUILDING EXTRA FEATURES(B) |             |     |       |            |        |          |      |       |            |             |
|--|-------------|-----|-------|------------|--------|----------|------|-------|------------|-------------|
| Code   | Description | L/B | Units | Unit Price | Yr Blt | Cond. Cd | % Gd | Grade | Grade Adj. | Appr. Value |
| FPL3   | FPL MSNRY 2 | B   | 2     | 4000.00    | 2013   |          | 100  |       | 0.00       | 8,000       |
| FPL2   | FPL MSNRY 1 | B   | 1     | 3500.00    | 2013   |          | 100  |       | 0.00       | 3,500       |
| DCK1   | DOCKS-RES   | L   | 520   | 95.00      | 2004   |          | 90   |       | 0.00       | 44,500      |
| WDK  | WOOD DECK   | L   | 500   | 20.00      | 2006   |          | 100  |       | 0.00       | 10,000      |
| ODS  | OUTDOOR S   | L   | 1     | 700.00     |        |          | 100  |       | 0.00       | 700         |
| CAB2   | CABIN AVE/G | L   | 360   | 40.00      |        |          | 100  |       | 0.00       | 14,400      |

| BUILDING SUB-AREA SUMMARY SECTION |                         |             |            |          |           |                |
|-----------------------------------|-------------------------|-------------|------------|----------|-----------|----------------|
| Code                              | Description             | Living Area | Floor Area | Eff Area | Unit Cost | Undeprec Value |
| BAS                               | First Floor             | 2,384       | 2,384      | 2,384    | 1,374.76  | 3,277,428      |
| FBM                               | Basement, Finished      | 0           | 2,384      | 1,073    | 618.76    | 1,475,117      |
| FSP                               | Porch, Screen, Finished | 0           | 234        | 59       | 346.63    | 81,111         |
| FUS                               | Upper Story, Finished   | 2,384       | 2,384      | 2,384    | 1,374.76  | 3,277,428      |
| Ttl Gross Liv / Lease Area        |                         | 4,768       | 7,386      | 5,900    |           | 8,111,084      |



| CURRENT OWNER   |            | TOPO  | UTILITIES   | STRT / ROAD | LOCATION    | CURRENT ASSESSMENT           |   |                                |                                | 1302<br>EDGARTOWN, MA |           |            |                     |                |            |   |
|---|------------|---|---|-------------|-------------|------------------------------|---|--------------------------------|--------------------------------|-----------------------|-----------|------------|---------------------|----------------|------------|---|
| REYNOLDS JAMES F--TRS<br>CATALINA ISLAND NOMINEE TRUST<br>PO BOX 962049 |            |   |   |             |             | Description                  | Code  | Appraised                      | Assessed                       |                       |           |            |                     |                |            |   |
| BOSTON MA 02196   |            | <b>SUPPLEMENTAL DATA</b>  |   |             |             | RESIDENTL                    | 1090  | 11,470,400                     | 11,470,400                     | <b>VISION</b>         |           |            |                     |                |            |   |
|   |            | Alt Prcl ID<br>PLN#/Rec<br>Lot#<br>Plan Notes<br>Plan Notes<br>Plan Notes<br>GIS ID M_283001_792444 | Restriction<br>Hist Distrct<br>Other Note<br>UC-Misc 1<br>UC-Misc 2<br>Assoc Pid# |             | RES LND     | 1090                         | 15,667,800  | 15,667,800                     |                                |                       |           |            |                     |                |            |   |
|   |            |   |   |             |             | Total                        |   | 27,138,200                     | 27,138,200                     |                       |           |            |                     |                |            |   |
| RECORD OF OWNERSHIP   |            | BK-VOL/PAGE   | SALE DATE   | Q/U         | V/I         | SALE PRICE                   | VC  | PREVIOUS ASSESSMENTS (HISTORY) |                                |                       |           |            |                     |                |            |   |
| REYNOLDS JAMES F--TRS   |            | 0078 0059   | 06-30-2017  | U           | I           | 20,500,000                   | 1V  | Year                           | Code                           | Assessed              | Year      | Code       | Assessed            |                |            |   |
| MV OCEAN LLC  |            | 0070 0043   | 08-16-2010  | U           | I           | 17,375,000                   | 1V  | 2023                           | 1090                           | 8,906,200             | 2022      | 1090       | 6,762,800           |                |            |   |
| REYNOLDS JAMES F--TRS   |            | 0064 0341   | 02-16-2006  | U           | I           | 25,175,000                   | 1   |                                | 1090                           | 15,177,500            |           | 1090       | 14,036,346          |                |            |   |
| HEDLEY DAVID V & MICHELE  |            | 0041 0259   | 03-06-1990  | U           | I           | 1                            | 1   |                                |                                |                       |           |            |                     |                |            |   |
| HEDLEY DAVID V & MICHELE  |            | 0040 0225   | 01-20-1989  | U           | I           | 2,400,000                    | 1   |                                |                                |                       |           |            |                     |                |            |   |
|   |            |   |   |             |             | Total                        |   | 24,083,700                     | Total                          | 20,799,146            | Total     |            | 20,241,360          |                |            |   |
| EXEMPTIONS  |            |   | OTHER ASSESSMENTS   |             |             |                              | This signature acknowledges a visit by a Data Collector or Assessor |                                |                                |                       |           |            |                     |                |            |   |
| Year  | Code       | Description   | Amount  | Code        | Description | Number                       | Amount  | Comm Int                       |                                |                       |           |            |                     |                |            |   |
|   |            |   |   |             |             |                              |   |                                | <b>APPRAISED VALUE SUMMARY</b> |                       |           |            |                     |                |            |   |
| Total   |            |   | 0.00  |             |             |                              |   | Appraised Bldg. Value (Card)   |                                |                       |           | 11,159,800 |                     |                |            |   |
|   |            |   |   |             |             |                              |   | Appraised Xf (B) Value (Bldg)  |                                |                       |           | 11,500     |                     |                |            |   |
|   |            |   |   |             |             |                              |   | Appraised Ob (B) Value (Bldg)  |                                |                       |           | 299,100    |                     |                |            |   |
|   |            |   |   |             |             |                              |   | Appraised Land Value (Bldg)    |                                |                       |           | 15,667,800 |                     |                |            |   |
|   |            |   |   |             |             |                              |   | Special Land Value             |                                |                       |           | 0          |                     |                |            |   |
|   |            |   |   |             |             |                              |   | Total Appraised Parcel Value   |                                |                       |           | 27,138,200 |                     |                |            |   |
|   |            |   |   |             |             |                              |   | Valuation Method               |                                |                       |           | C          |                     |                |            |   |
|   |            |   |   |             |             | Total Appraised Parcel Value |   |                                |                                |                       |           |            | 27,138,200          |                |            |   |
| BUILDING PERMIT RECORD  |            |   |   |             |             |                              |   | VISIT / CHANGE HISTORY         |                                |                       |           |            |                     |                |            |   |
| Permit Id   | Issue Date | Type  | Description   | Amount      | Insp Date   | % Comp                       | Date Comp   | Comments                       | Date                           | Id                    | Type      | Is         | Cd                  | Purpost/Result |            |   |
|   |            |   |   |             |             |                              |   |                                |                                |                       |           |            |                     |                |            |   |
| LAND LINE VALUATION SECTION   |            |   |   |             |             |                              |   |                                |                                |                       |           |            |                     |                |            |   |
| B   | Use Code   | Description   | Zone  | Land Type   | Land Units  | Unit Price                   | Size Adj  | Site Index                     | Cond.                          | Nbhd.                 | Nbhd. Adj | Notes      | Location Adjustment | Adj Unit P     | Land Value |   |
| 2   | 1090       | MULTI HSES  | R60   |             | 0 SF        | 28.56                        | 1.00000   | 6                              | 1.00                           | 0090                  | 4.900     |            |                     | 139.94         | 0          |   |
| 2   | 1090       | MULTI HSES  | R60   |             | 30 FF       | 0.01                         | 1.00000   | 0                              | 1.00                           | 0090                  | 4.900     |            |                     | 0.05           | 0          |   |
| Total Card Land Units   |            |   |   |             | 0.00        | AC                           | Parcel Total Land Area  |                                |                                |                       |           | 3.40       | Total Land Value    |                |            | 0 |

| CONSTRUCTION DETAIL            |      |                | CONSTRUCTION DETAIL (CONTINUED) |     |             |
|--------------------------------|------|----------------|---------------------------------|-----|-------------|
| Element                        | Cd   | Description    | Element                         | Cd  | Description |
| Style:                         | 06   | Custom         |                                 |     |             |
| Model                          | 01   | Residential    |                                 |     |             |
| Grade:                         | 07   | Very Good      |                                 |     |             |
| Stories:                       | 2    |                |                                 |     |             |
| Occupancy                      | 1    |                |                                 |     |             |
| Exterior Wall 1                | 10   | Above Average  |                                 |     |             |
| Exterior Wall 2                | 21   | Stone/Masonry  |                                 |     |             |
| Roof Structure:                | 05   | Salt Box       |                                 |     |             |
| Roof Cover                     | 01   | Metal/Tin      |                                 |     |             |
| Interior Wall 1                | 03   | Plastered      |                                 |     |             |
| Interior Wall 2                |      |                |                                 |     |             |
| Interior Flr 1                 | 12   | Hardwood       |                                 |     |             |
| Interior Flr 2                 | 04   | Concr Abv Grad |                                 |     |             |
| Heat Fuel                      | 03   | Gas            |                                 |     |             |
| Heat Type:                     | 04   | Forced Air-Duc |                                 |     |             |
| AC Type:                       | 03   | Central        |                                 |     |             |
| Total Bedrooms                 | 01   | 1 Bedroom      |                                 |     |             |
| Total Bthrms:                  | 1    |                |                                 |     |             |
| Total Half Baths               | 0    |                |                                 |     |             |
| Total Xtra Fixtrs              | 2    |                |                                 |     |             |
| Total Rooms:                   | 4    | 4 Rooms        |                                 |     |             |
| Bath Style:                    | 02   | Average        |                                 |     |             |
| Kitchen Style:                 | 02   | Modern         |                                 |     |             |
| <b>CONDO DATA</b>              |      |                |                                 |     |             |
| Parcel Id                      |      | C              | Ownr                            | 0.0 |             |
|                                |      |                | B                               | S   |             |
| Adjust Type                    | Code | Description    | Factor%                         |     |             |
| Condo Flr                      |      |                |                                 |     |             |
| Condo Unit                     |      |                |                                 |     |             |
| <b>COST / MARKET VALUATION</b> |      |                |                                 |     |             |
| Building Value New             |      | 1,333,947      |                                 |     |             |
| Year Built                     |      | 2023           |                                 |     |             |
| Effective Year Built           |      | 2022           |                                 |     |             |
| Depreciation Code              |      | A              |                                 |     |             |
| Remodel Rating                 |      |                |                                 |     |             |
| Year Remodeled                 |      |                |                                 |     |             |
| Depreciation %                 |      | 0              |                                 |     |             |
| Functional Obsol               |      | 0              |                                 |     |             |
| External Obsol                 |      | 0              |                                 |     |             |
| Trend Factor                   |      | 1              |                                 |     |             |
| Condition                      |      |                |                                 |     |             |
| Condition %                    |      |                |                                 |     |             |
| Percent Good                   |      | 100            |                                 |     |             |
| Cns Sect Rcnd                  |      | 1,333,900      |                                 |     |             |
| Dep % Ovr                      |      |                |                                 |     |             |
| Dep Ovr Comment                |      |                |                                 |     |             |
| Misc Imp Ovr                   |      |                |                                 |     |             |
| Misc Imp Ovr Comment           |      |                |                                 |     |             |
| Cost to Cure Ovr               |      |                |                                 |     |             |
| Cost to Cure Ovr Comment       |      |                |                                 |     |             |

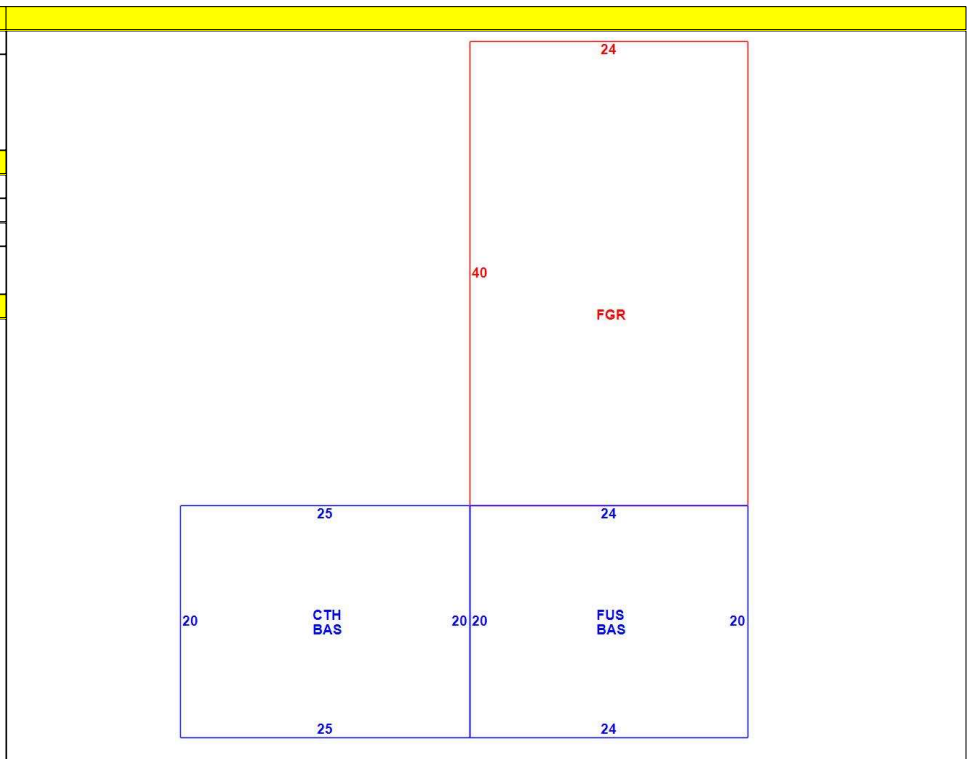

**OB - OUTBUILDING & YARD ITEMS(L) / XF - BUILDING EXTRA FEATURES(B)**

| Code | Description | L/B | Units | Unit Price | Yr Blt | Cond. Cd | % Gd | Grade | Grade Adj. | Appr. Value |
|------|-------------|-----|-------|------------|--------|----------|------|-------|------------|-------------|
| SHED | SHED FRAME  | L   | 1     | 1000.00    |        |          | 100  |       | 0.00       | 1,000       |
| MSC3 | PERGOLA     | L   | 2,550 | 15.00      | 2006   |          | 100  |       | 0.00       | 38,300      |

**BUILDING SUB-AREA SUMMARY SECTION**

| Code                       | Description           | Living Area | Floor Area | Eff Area | Unit Cost | Undeprec Value |
|----------------------------|-----------------------|-------------|------------|----------|-----------|----------------|
| BAS                        | First Floor           | 980         | 980        | 980      | 712.40    | 698,148        |
| CTH                        | Cath Cing             | 0           | 500        | 25       | 35.62     | 17,810         |
| FGR                        | Garage                | 0           | 960        | 384      | 284.96    | 273,560        |
| FUS                        | Upper Story, Finished | 480         | 480        | 480      | 712.40    | 341,950        |
| Ttl Gross Liv / Lease Area |                       | 1,460       | 2,920      | 1,869    |           | 1,331,468      |





| CURRENT OWNER   |            | TOPO  | UTILITIES   | STRT / ROAD | LOCATION    | CURRENT ASSESSMENT |   |                                |                                | 1302<br>EDGARTOWN, MA |                  |            |                     |                |            |
|---|------------|---|---|-------------|-------------|--------------------|---|--------------------------------|--------------------------------|-----------------------|------------------|------------|---------------------|----------------|------------|
| REYNOLDS JAMES F--TRS<br>CATALINA ISLAND NOMINEE TRUST<br>PO BOX 962049 |            |   |   |             |             | Description        | Code  | Appraised                      | Assessed                       |                       |                  |            |                     |                |            |
| BOSTON MA 02196   |            | <b>SUPPLEMENTAL DATA</b>  |   |             |             | RESIDENTL          | 1090  | 11,470,400                     | 11,470,400                     | <b>VISION</b>         |                  |            |                     |                |            |
|   |            | Alt Prcl ID<br>PLN#/Rec<br>Lot#<br>Plan Notes<br>Plan Notes<br>Plan Notes<br>GIS ID M_283001_792444 | Restriction<br>Hist Distrct<br>Other Note<br>UC-Misc 1<br>UC-Misc 2<br>Assoc Pid# | RES LND     | 1090        | 15,667,800         | 15,667,800  |                                |                                |                       |                  |            |                     |                |            |
|   |            |   |   |             |             | Total              |   | 27,138,200                     | 27,138,200                     |                       |                  |            |                     |                |            |
| RECORD OF OWNERSHIP   |            | BK-VOL/PAGE   | SALE DATE   | Q/U         | V/I         | SALE PRICE         | VC  | PREVIOUS ASSESSMENTS (HISTORY) |                                |                       |                  |            |                     |                |            |
| REYNOLDS JAMES F--TRS   |            | 0078 0059   | 06-30-2017  | U           | I           | 20,500,000         | 1V  | Year                           | Code                           | Assessed              | Year             | Code       | Assessed            |                |            |
| MV OCEAN LLC  |            | 0070 0043   | 08-16-2010  | U           | I           | 17,375,000         | 1V  | 2023                           | 1090                           | 8,906,200             | 2022             | 1090       | 6,762,800           |                |            |
| REYNOLDS JAMES F--TRS   |            | 0064 0341   | 02-16-2006  | U           | I           | 25,175,000         | 1   |                                | 1090                           | 15,177,500            |                  | 1090       | 14,036,346          |                |            |
| HEDLEY DAVID V & MICHELE  |            | 0041 0259   | 03-06-1990  | U           | I           | 1                  | 1   |                                |                                |                       |                  | 1090       | 7,492,100           |                |            |
| HEDLEY DAVID V & MICHELE  |            | 0040 0225   | 01-20-1989  | U           | I           | 2,400,000          | 1   |                                |                                |                       |                  | 1090       | 12,749,260          |                |            |
|   |            |   |   |             |             | Total              |   | 24,083,700                     | Total                          | 20,799,146            | Total            |            | 20,241,360          |                |            |
| EXEMPTIONS  |            |   | OTHER ASSESSMENTS   |             |             |                    | This signature acknowledges a visit by a Data Collector or Assessor |                                |                                |                       |                  |            |                     |                |            |
| Year  | Code       | Description   | Amount  | Code        | Description | Number             | Amount  | Comm Int                       |                                |                       |                  |            |                     |                |            |
|   |            |   |   |             |             |                    |   |                                | <b>APPRAISED VALUE SUMMARY</b> |                       |                  |            |                     |                |            |
| Total   |            |   | 0.00  |             |             |                    |   | Appraised Bldg. Value (Card)   |                                |                       |                  | 11,159,800 |                     |                |            |
|   |            |   |   |             |             |                    |   | Appraised Xf (B) Value (Bldg)  |                                |                       |                  | 11,500     |                     |                |            |
|   |            |   |   |             |             |                    |   | Appraised Ob (B) Value (Bldg)  |                                |                       |                  | 299,100    |                     |                |            |
|   |            |   |   |             |             |                    |   | Appraised Land Value (Bldg)    |                                |                       |                  | 15,667,800 |                     |                |            |
|   |            |   |   |             |             |                    |   | Special Land Value             |                                |                       |                  | 0          |                     |                |            |
|   |            |   |   |             |             |                    |   | Total Appraised Parcel Value   |                                |                       |                  | 27,138,200 |                     |                |            |
|   |            |   |   |             |             |                    |   | Valuation Method               |                                |                       |                  | C          |                     |                |            |
|   |            |   |   |             |             |                    |   | Total Appraised Parcel Value   |                                |                       |                  | 27,138,200 |                     |                |            |
| BUILDING PERMIT RECORD  |            |   |   |             |             |                    | VISIT / CHANGE HISTORY  |                                |                                |                       |                  |            |                     |                |            |
| Permit Id   | Issue Date | Type  | Description   | Amount      | Insp Date   | % Comp             | Date Comp   | Comments                       | Date                           | Id                    | Type             | Is         | Cd                  | Purpost/Result |            |
|   |            |   |   |             |             |                    |   |                                |                                |                       |                  |            |                     |                |            |
| LAND LINE VALUATION SECTION   |            |   |   |             |             |                    |   |                                |                                |                       |                  |            |                     |                |            |
| B   | Use Code   | Description   | Zone  | Land Type   | Land Units  | Unit Price         | Size Adj  | Site Index                     | Cond.                          | Nbhd.                 | Nbhd. Adj        | Notes      | Location Adjustment | Adj Unit P     | Land Value |
| 3   | 1090       | MULTI HSES  |   |             | 0 SF        | 0.00               | 1.00000   |                                | 1.00                           | 0090                  | 4.900            |            |                     | 0              | 0          |
| Total Card Land Units   |            |   |   |             | 0.00        | AC                 | Parcel Total Land Area  |                                |                                | 3.40                  | Total Land Value |            |                     |                | 0          |

| CONSTRUCTION DETAIL |    |                | CONSTRUCTION DETAIL (CONTINUED) |    |             |
|---------------------|----|----------------|---------------------------------|----|-------------|
| Element             | Cd | Description    | Element                         | Cd | Description |
| Style:              | 06 | Custom         |                                 |    |             |
| Model               | 01 | Residential    |                                 |    |             |
| Grade:              | 07 | Very Good      |                                 |    |             |
| Stories:            | 2  |                |                                 |    |             |
| Occupancy           | 1  |                |                                 |    |             |
| Exterior Wall 1     | 10 | Above Average  |                                 |    |             |
| Exterior Wall 2     |    |                |                                 |    |             |
| Roof Structure:     | 05 | Salt Box       |                                 |    |             |
| Roof Cover          | 01 | Metal/Tin      |                                 |    |             |
| Interior Wall 1     | 03 | Plastered      |                                 |    |             |
| Interior Wall 2     | 06 | Cust Wd Panel  |                                 |    |             |
| Interior Flr 1      | 15 | Quarry Tile    |                                 |    |             |
| Interior Flr 2      | 12 | Hardwood       |                                 |    |             |
| Heat Fuel           | 03 | Gas            |                                 |    |             |
| Heat Type:          | 04 | Forced Air-Duc |                                 |    |             |
| AC Type:            | 03 | Central        |                                 |    |             |
| Total Bedrooms      | 02 | 2 Bedrooms     |                                 |    |             |
| Total Bthrms:       | 2  |                |                                 |    |             |
| Total Half Baths    | 1  |                |                                 |    |             |
| Total Xtra Fixtrs   | 3  |                |                                 |    |             |
| Total Rooms:        |    |                |                                 |    |             |
| Bath Style:         | 03 | Modern         |                                 |    |             |
| Kitchen Style:      |    |                |                                 |    |             |

| CONDO DATA               |      |             |           |
|--------------------------|------|-------------|-----------|
| Parcel Id                |      | C           | Ownr      |
|                          |      |             | 0.0       |
|                          |      | B           | S         |
| Adjust Type              | Code | Description | Factor%   |
| Condo Flr                |      |             |           |
| Condo Unit               |      |             |           |
| COST / MARKET VALUATION  |      |             |           |
| Building Value New       |      |             | 1,680,202 |
| Year Built               |      |             | 2023      |
| Effective Year Built     |      |             | 2022      |
| Depreciation Code        |      |             | A         |
| Remodel Rating           |      |             |           |
| Year Remodeled           |      |             |           |
| Depreciation %           |      |             | 0         |
| Functional Obsol         |      |             |           |
| External Obsol           |      |             |           |
| Trend Factor             |      |             | 1         |
| Condition                |      |             |           |
| Condition %              |      |             |           |
| Percent Good             |      |             | 100       |
| Cns Sect Rcnd            |      |             | 1,680,200 |
| Dep % Ovr                |      |             |           |
| Dep Ovr Comment          |      |             |           |
| Misc Imp Ovr             |      |             |           |
| Misc Imp Ovr Comment     |      |             |           |
| Cost to Cure Ovr         |      |             |           |
| Cost to Cure Ovr Comment |      |             |           |



**OB - OUTBUILDING & YARD ITEMS(L) / XF - BUILDING EXTRA FEATURES(B)**

| Code | Description | L/B | Units | Unit Price | Yr Blt | Cond. Cd | % Gd | Grade | Grade Adj. | Appr. Value |
|------|-------------|-----|-------|------------|--------|----------|------|-------|------------|-------------|
| SPL3 | INGR GUNITE | L   | 1,496 | 100.00     | 2006   |          | 100  |       | 0.00       | 149,600     |
| ODP  | OUTDOOR PL  | L   | 1     | 700.00     | 2006   |          | 100  |       | 0.00       | 700         |
| PAT2 | PATIO-GOOD  | L   | 5,700 | 7.00       | 2006   |          | 100  |       | 0.00       | 39,900      |

**BUILDING SUB-AREA SUMMARY SECTION**

| Code                       | Description           | Living Area | Floor Area | Eff Area | Unit Cost | Undeprec Value |
|----------------------------|-----------------------|-------------|------------|----------|-----------|----------------|
| BAS                        | First Floor           | 969         | 969        | 969      | 780.89    | 756,682        |
| FUS                        | Upper Story, Finished | 969         | 969        | 969      | 780.89    | 756,682        |
| UBM                        | Basement, Unfinished  | 0           | 969        | 194      | 156.34    | 151,493        |
| Ttl Gross Liv / Lease Area |                       | 1,938       | 2,907      | 2,132    |           | 1,664,857      |

