

| CURRENT OWNER | | | | TOPO | UTILITIES | STRT / ROAD | LOCATION | CURRENT ASSESSMENT | | | | |
|-----------------------------------------------------------|--|--|--|---------------------------------------------------------------------------------------------|-----------|-------------|---------------------------------------------------------------------|--------------------|-------|--------------------------------------|-----------|-----------------------|
| AURAY THOMAS S & AURAY DEA PAOLETTA 15 FLAT ROCK RD | | | | | | | | Description | Code | Appraised | Assessed | 1302 EDGARTOWN, MA |
| | | | | | | | | RESIDENTL | 1010 | 1,061,800 | 1,061,800 | |
| | | | | | | | | RES LND | 1010 | 1,051,400 | 1,051,400 | |
| SUPPLEMENTAL DATA | | | | | | | | | | | | |
| EASTON CT 06612 | | | | Alt Prcl ID PLN#/Rec CF 232 GAZAILLE Lot# 3 Plan Notes Plan Notes Plan Notes | | | Restriction Hist Distrct Other Note UC-Misc 1 UC-Misc 2 | | | GIS ID M_281771_793130 Assoc Pid# | | |
| | | | | | | | | | Total | 2,113,200 | 2,113,200 | |

VISION

| RECORD OF OWNERSHIP | | | | BK-VOL/PAGE | SALE DATE | Q/U | V/I | SALE PRICE | VC | PREVIOUS ASSESSMENTS (HISTORY) | | | | | | | | | | |
|-------------------------------------------|--|--|--|--------------|--------------|--------------------------|--------|------------|----------------------|--------------------------------|-------|-----------|-----------|-----------|-------|-----------|------|------|----------|--|
| AURAY THOMAS S & MASSEY FAMILY LIMITED | | | | 1477 1291 | 1036 0995 | 10-01-2018 09-12-2012 | Q U | I I | 1,505,000 740,000 | 00 1 | Year | Code | Assessed | Year | Code | Assessed | Year | Code | Assessed | |
| OWENS HELENE F | | | | 010P | 0078 | 06-18-2010 | U | I | 1 | 1A | 2023 | 1010 | 1,003,100 | 2022 | 1010 | 603,500 | 2021 | 1010 | 559,400 | |
| OWENS HELEN B | | | | 00427 | 0549 | 04-22-1985 | Q | V | 60,000 | 00 | | 1010 | 1,097,400 | | 1010 | 776,400 | | 1010 | 778,600 | |
| COURTNEY EUGENE J | | | | 00397 | 0631 | 12-02-1982 | U | V | 60,000 | 1 | | | | | | | | | | |
| | | | | | | | | | | | Total | 2,100,500 | Total | 1,379,900 | Total | 1,338,000 | | | | |

| EXEMPTIONS | | | | OTHER ASSESSMENTS | | | | |
|------------|------|-------------|--------|-------------------|-------------|--------|--------|----------|
| Year | Code | Description | Amount | Code | Description | Number | Amount | Comm Int |
| | | | Total | | | | | 0.00 |

This signature acknowledges a visit by a Data Collector or Assessor

| ASSESSING NEIGHBORHOOD | | | | |
|------------------------|-----------|---|---------|-------|
| Nbhd | Nbhd Name | B | Tracing | Batch |
| 0060 | | | | |

| APPRAISED VALUE SUMMARY | | | |
|-------------------------------|-----------|--|--|
| Appraised Bldg. Value (Card) | 1,009,400 | | |
| Appraised Xf (B) Value (Bldg) | 3,900 | | |
| Appraised Ob (B) Value (Bldg) | 48,500 | | |
| Appraised Land Value (Bldg) | 1,051,400 | | |
| Special Land Value | 0 | | |
| Total Appraised Parcel Value | 2,113,200 | | |
| Valuation Method | C | | |
| Total Appraised Parcel Value | 2,113,200 | | |

| BUILDING PERMIT RECORD | | | | | | | | | | VISIT / CHANGE HISTORY | | | | | | |
|------------------------|------------|------|---------------|---------|-----------|--------|-----------|--------------------------|--|------------------------|------------|----|------|----|----|-----------------------|
| Permit Id | Issue Date | Type | Description | Amount | Insp Date | % Comp | Date Comp | Comments | | | Date | Id | Type | Is | Cd | Purpost/Result |
| 2024-244 | 10-05-2023 | RA | Res Add/Alter | | | 0 | | MOVE SHED | | | 06-06-2022 | EH | | | 01 | Cyclical Reinspection |
| 2024-226 | 09-22-2023 | RN | Res New Cons | | | 0 | | BUILD FGR WITH LIVING | | | 05-31-2022 | LS | | | 11 | Field Review |
| 2022-19 | 08-03-2021 | RA | Res Add/Alter | 12,900 | | | | REMOV DECK/BLD NEW | | | 05-19-2020 | EP | | | 01 | Cyclical Reinspection |
| 2021-865 | 06-09-2021 | RN | Res New Cons | 91,000 | | | | INSTALL INGROUND POOL | | | 11-30-2018 | EP | | | 01 | Cyclical Reinspection |
| 2019-679 | 05-07-2019 | RA | Res Add/Alter | 100,000 | | 0 | | RENOVATE/ RECONFIGURE | | | 05-16-2017 | MM | | | 11 | Field Review |
| 86-2013 | 03-07-2013 | CO | CO ISSUED | | | | | SFR ALTS | | | 03-25-2014 | EP | | | 01 | Cyclical Reinspection |
| 2013-86 | 10-12-2012 | RA | Res Add/Alter | | | | | KITCH ALTS 10 X 16 WDK & | | | 02-14-2013 | EP | | | 01 | Cyclical Reinspection |

| LAND LINE VALUATION SECTION | | | | | | | | | | | | | | | | |
|-----------------------------|----------|---------------|------|-----------|------------|------------------------|----------|------------|-------|-------|-----------|------------------|---------------------|------------|------------|-----------|
| B | Use Code | Description | Zone | Land Type | Land Units | Unit Price | Size Adj | Site Index | Cond. | Nbhd. | Nbhd. Adj | Notes | Location Adjustment | Adj Unit P | Land Value | |
| 1 | 1010 | SINGL FAM M-0 | R20 | | 21,780 SF | 14.57 | 1.00000 | 5 | 1.00 | 0070 | 3.200 | | | 46.62 | 1,015,500 | |
| 1 | 1010 | SINGL FAM M-0 | R20 | | 0.330 AC | 34,000.00 | 1.00000 | 0 | 1.00 | 0070 | 3.200 | | | 108,800 | 35,900 | |
| Total Card Land Units | | | | | 0.83 AC | Parcel Total Land Area | | | | | 0.83 | Total Land Value | | | | 1,051,400 |

| CONSTRUCTION DETAIL | | | CONSTRUCTION DETAIL (CONTINUED) | | |
|---------------------|------|----------------|---------------------------------|----|-------------|
| Element | Cd | Description | Element | Cd | Description |
| Style: | 04 | Cape Cod | | | |
| Model | 01 | Residential | | | |
| Grade: | 04 | Above Ave | | | |
| Stories: | 1.75 | | | | |
| Occupancy | 1 | | | | |
| Exterior Wall 1 | 14 | Wood Shingle | | | |
| Exterior Wall 2 | | | | | |
| Roof Structure: | 03 | Gable/Hip | | | |
| Roof Cover | 03 | Asph/F Gls/Cmp | | | |
| Interior Wall 1 | 05 | Drywall/Sheet | | | |
| Interior Wall 2 | | | | | |
| Interior Flr 1 | 12 | Hardwood | | | |
| Interior Flr 2 | 11 | Ceram Clay Til | | | |
| Heat Fuel | 03 | Gas | | | |
| Heat Type: | 05 | Hot Water | | | |
| AC Type: | 02 | Heat Pump | | | |
| Total Bedrooms | 04 | 4 Bedrooms | | | |
| Total Bthrms: | 3 | | | | |
| Total Half Baths | 0 | | | | |
| Total Xtra Fixtrs | | | | | |
| Total Rooms: | | | | | |
| Bath Style: | | | | | |
| Kitchen Style: | | | | | |

| CONDO DATA | | | | |
|-------------|------|-------------|---------|----------|
| Parcel Id | | C | | Owne 0.0 |
| | | | B | S |
| Adjust Type | Code | Description | Factor% | |
| Condo Flr | | | | |
| Condo Unit | | | | |

| COST / MARKET VALUATION | |
|--------------------------|-----------|
| Building Value New | 1,040,656 |
| Year Built | 1986 |
| Effective Year Built | 2019 |
| Depreciation Code | R |
| Remodel Rating | |
| Year Remodeled | 2013 |
| Depreciation % | 3 |
| Functional Obsol | 0 |
| External Obsol | 0 |
| Trend Factor | 1 |
| Condition | |
| Condition % | |
| Percent Good | 97 |
| Cns Sect Rcnld | 1,009,400 |
| Dep % Ovr | |
| Dep Ovr Comment | |
| Misc Imp Ovr | |
| Misc Imp Ovr Comment | |
| Cost to Cure Ovr | |
| Cost to Cure Ovr Comment | |

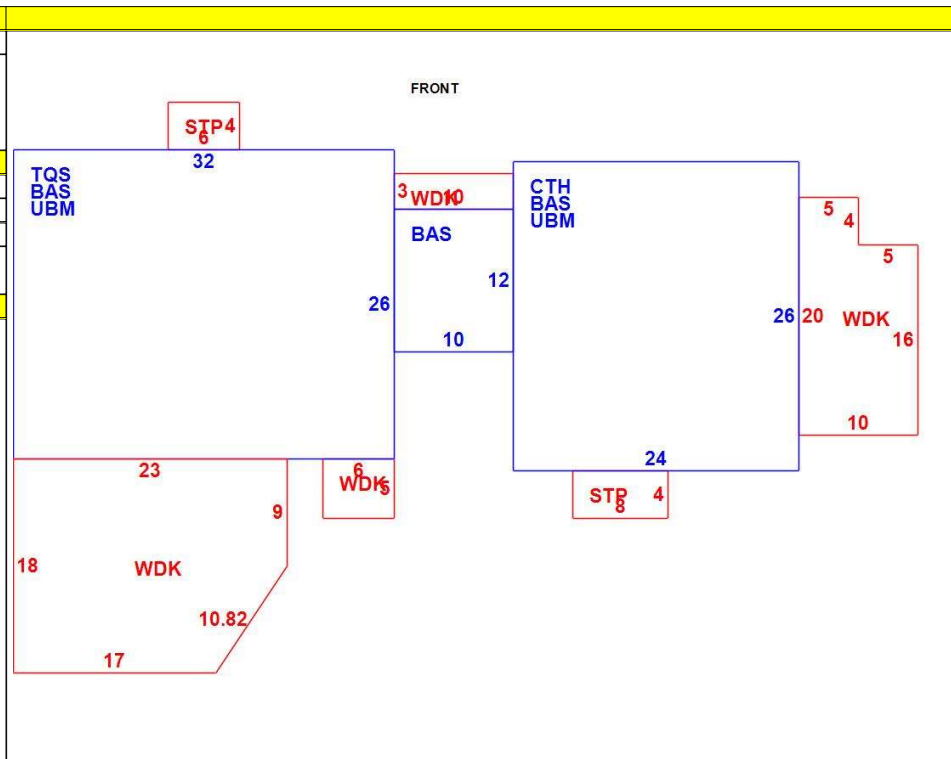

| OB - OUTBUILDING & YARD ITEMS(L) / XF - BUILDING EXTRA FEATURES(B) | | | | | | | | | | |
|--------------------------------------------------------------------|-------------|-----|-------|------------|--------|----------|------|-------|------------|-------------|
| Code | Description | L/B | Units | Unit Price | Yr Blt | Cond. Cd | % Gd | Grade | Grade Adj. | Appr. Value |
| FPL3 | FPL MSNRY 2 | B | 1 | 4000.00 | 2013 | | 97 | | 0.00 | 3,900 |
| ODS | OUTDOOR S | L | 2 | 700.00 | | | 100 | | 0.00 | 1,400 |
| SPL3 | INGR GUNITE | L | 420 | 100.00 | | | 100 | | 0.00 | 42,000 |
| SHD2 | W/LIGHTS ET | L | 120 | 18.00 | | | 100 | | 0.00 | 2,200 |
| SHD1 | SHED FRAME | L | 180 | 16.00 | | | 100 | | 0.00 | 2,900 |

| BUILDING SUB-AREA SUMMARY SECTION | | | | | | |
|-----------------------------------|----------------------|-------------|------------|----------|-----------|----------------|
| Code | Description | Living Area | Floor Area | Eff Area | Unit Cost | Undeprec Value |
| BAS | First Floor | 1,576 | 1,576 | 1,576 | 397.40 | 626,298 |
| CTH | Cath Cing | 0 | 624 | 31 | 19.74 | 12,319 |
| STP | Stoop | 0 | 56 | 6 | 42.58 | 2,384 |
| TQS | Three Quarter Story | 624 | 832 | 624 | 298.05 | 247,976 |
| UBM | Basement, Unfinished | 0 | 1,456 | 291 | 79.42 | 115,643 |
| WDK | Deck, Wood | 0 | 627 | 63 | 39.93 | 25,036 |
| Ttl Gross Liv / Lease Area | | 2,200 | 5,171 | 2,591 | | 1,029,656 |