

CONSTRUCTION DETAIL			CONSTRUCTION DETAIL (CONTINUED)		
Element	Cd	Description	Element	Cd	Description
Style:	07	Standard Plus			
Model	01	Residential			
Grade:	05	Average +20			
Stories:	2	2 Stories			
Occupancy	1				
Exterior Wall 1	14	Wood Shingle			
Exterior Wall 2					
Roof Structure:	03	Gable/Hip			
Roof Cover	03	Asph/F Gls/Cmp			
Interior Wall 1	05	Drywall/Sheet			
Interior Wall 2	06	Cust Wd Panel			
Interior Flr 1	12	Hardwood			
Interior Flr 2	14	Carpet			
Heat Fuel	04	Electric			
Heat Type:	07	Electr Basebrd			
AC Type:	01	None			
Total Bedrooms	04	4 Bedrooms			
Total Bthrms:	2				
Total Half Baths	0				
Total Xtra Fixtrs					
Total Rooms:	10				
Bath Style:	03	Modern			
Kitchen Style:	03	Luxurious			
CONDO DATA					
Parcel Id		C	Owne	0.0	
Adjust Type	Code	Description	Factor%		
Condo Flr					
Condo Unit					
COST / MARKET VALUATION					
Building Value New			1,567,535		
Year Built			1979		
Effective Year Built			2019		
Depreciation Code			R		
Remodel Rating					
Year Remodeled			2014		
Depreciation %			3		
Functional Obsol			0		
External Obsol			0		
Trend Factor			1		
Condition					
Condition %					
Percent Good			97		
Cns Sect Rcnld			1,520,500		
Dep % Ovr					
Dep Ovr Comment					
Misc Imp Ovr					
Misc Imp Ovr Comment					
Cost to Cure Ovr					
Cost to Cure Ovr Comment					

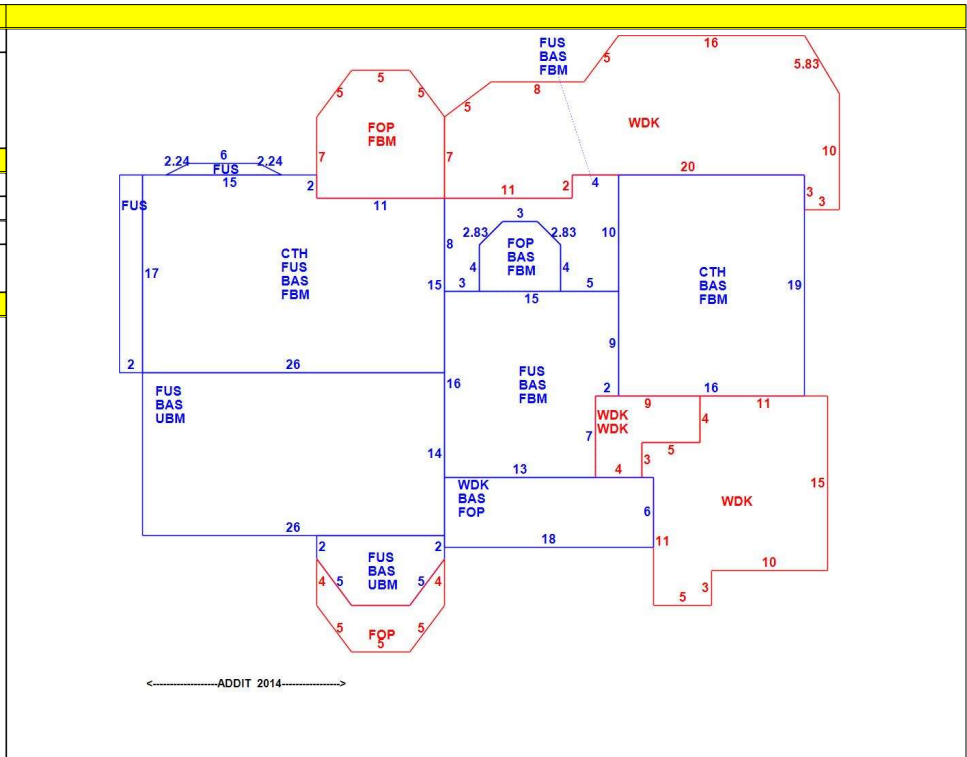

OB - OUTBUILDING & YARD ITEMS(L) / XF - BUILDING EXTRA FEATURES(B)										
Code	Description	L/B	Units	Unit Price	Yr Blt	Cond. Cd	% Gd	Grade	Grade Adj.	Appr. Value
FPL	MTL-WD C/PI	B	1	2000.00	2013		97		0.00	1,900
SNA	SAUNA	B	96	80.00	2013		97		0.00	7,400
SHD1	SHED FRAME	L	48	16.00			75		0.00	600

BUILDING SUB-AREA SUMMARY SECTION						
Code	Description	Living Area	Floor Area	Eff Area	Unit Cost	Undeprec Value
BAS	First Floor	1,604	1,604	1,604	434.48	696,912
CTH	Cath Cing	0	724	36	21.60	15,641
FBM	Basement, Finished	0	1,187	534	195.46	232,014
FOP	Porch, Open, Finished	0	299	60	87.19	26,069
FUS	Upper Story, Finished	1,196	1,196	1,196	434.48	519,643
UBM	Basement, Unfinished	0	418	84	87.31	36,497
WDK	Deck, Wood	0	803	80	43.29	34,759
Ttl Gross Liv / Lease Area		2,800	6,231	3,594		1,561,535

