

CURRENT OWNER		TOPO	UTILITIES	STRT / ROAD	LOCATION	CURRENT ASSESSMENT			
LUETH RICHARD A II--TRS			2 Public Water			Description	Code	Appraised	Assessed
LUETH DOROTHY FAITH--TRS						RESIDENTL	1010	312,200	312,200
16 HICKORY LN						RES LND	1010	318,100	318,100
SUPPLEMENTAL DATA									
FRAMINGHAM MA 01701-3036		Alt Prcl ID	Restriction						
		PLN#/Rec	Hist Distrct						
		Lot#	Other Note						
		Plan Notes	UC-Misc 1						
		Plan Notes	UC-Misc 2						
		Plan Notes							
		GIS ID	M_277800_794648		Assoc Pid#				
Total							630,300		630,300

1302
 EDGARTOWN, MA
VISION

RECORD OF OWNERSHIP		BK-VOL/PAGE	SALE DATE	Q/U	V/I	SALE PRICE	VC	PREVIOUS ASSESSMENTS (HISTORY)							
LUETH RICHARD A II--TRS		1575 193	04-22-2021	U	I	1	1A	Year	Code	Assessed	Year	Code	Assessed		
LUETH RICHARD A II & FAITH M		0576 0279	03-30-1992	Q	I	117,000	00	2023	1010	342,800	2022	1010	236,700		
MCHUGH ROBERT E		00446 0682	05-01-1986	Q	I	128,500	00		1010	348,500		1010	333,400		
BOLDT BENJAMIN J, BETTY J &		00428 0439	05-09-1985	U	V	1	1B								
EDG COUNTRY FARMS TRS		0401 0056	04-22-1983	U	V	267,000	1								
Total							691,300		Total		570,100		Total		542,600

EXEMPTIONS			OTHER ASSESSMENTS					
Year	Code	Description	Amount	Code	Description	Number	Amount	Comm Int
Total			0.00					

This signature acknowledges a visit by a Data Collector or Assessor

ASSESSING NEIGHBORHOOD				
Nbhd	Nbhd Name	B	Tracing	Batch
0045				

APPRAISED VALUE SUMMARY	
Appraised Bldg. Value (Card)	310,700
Appraised Xf (B) Value (Bldg)	0
Appraised Ob (B) Value (Bldg)	1,500
Appraised Land Value (Bldg)	318,100
Special Land Value	0
Total Appraised Parcel Value	630,300
Valuation Method	C
Total Appraised Parcel Value	630,300

BUILDING PERMIT RECORD								VISIT / CHANGE HISTORY						
Permit Id	Issue Date	Type	Description	Amount	Insp Date	% Comp	Date Comp	Comments	Date	Id	Type	Is	Cd	Purpost/Result
									08-22-2022	EH		6	01	Cyclical Reinspection
									05-25-2022	DM			11	Field Review
									05-25-2017	AU			11	Field Review
									11-15-2011	RK			11	Field Review
									08-27-2004	EP			51	Cyclical Reinspection
									07-26-2000	WP			43	Cyclical Reinspection
									04-01-1980					

LAND LINE VALUATION SECTION																
B	Use Code	Description	Zone	Land Type	Land Units	Unit Price	Size Adj	Site Index	Cond.	Nbhd.	Nbhd. Adj	Notes	Location Adjustment	Adj Unit P	Land Value	
1	1010	SINGL FAM M-0	R60		21,978 SF	14.47	1.00000	4	1.00	0045	1.000			14.47	318,100	
Total Card Land Units					0.50	AC	Parcel Total Land Area					0.50	Total Land Value			318,100

CONSTRUCTION DETAIL			CONSTRUCTION DETAIL (CONTINUED)		
Element	Cd	Description	Element	Cd	Description
Style:	63	Modern/Contemporary			
Model	01	Residential			
Grade:	04	Above Ave			
Stories:	1.75				
Occupancy	1				
Exterior Wall 1	14	Wood Shingle			
Exterior Wall 2					
Roof Structure:	03	Gable/Hip			
Roof Cover	03	Asph/F GlS/Cmp			
Interior Wall 1	05	Drywall/Sheet			
Interior Wall 2					
Interior Flr 1	14	Carpet			
Interior Flr 2					
Heat Fuel	04	Electric			
Heat Type:	07	Electr Basebrd			
AC Type:	03	Central			
Total Bedrooms	03	3 Bedrooms			
Total Bthrms:	2				
Total Half Baths	0				
Total Xtra Fixtrs					
Total Rooms:	5				
Bath Style:	02	Average			
Kitchen Style:	02	Modern			
			CONDO DATA		
			Parcel Id		C
					Owne 0.0
					B S
			Adjust Type	Code	Description
					Factor%
					Condo Flr
					Condo Unit
			COST / MARKET VALUATION		
			Building Value New		365,561
			Year Built		1985
			Effective Year Built		2007
			Depreciation Code		G
			Remodel Rating		
			Year Remodeled		
			Depreciation %		15
			Functional Obsol		0
			External Obsol		0
			Trend Factor		1
			Condition		
			Condition %		
			Percent Good		85
			Cns Sect Rcnd		310,700
			Dep % Ovr		
			Dep Ovr Comment		
			Misc Imp Ovr		
			Misc Imp Ovr Comment		
			Cost to Cure Ovr		
			Cost to Cure Ovr Comment		

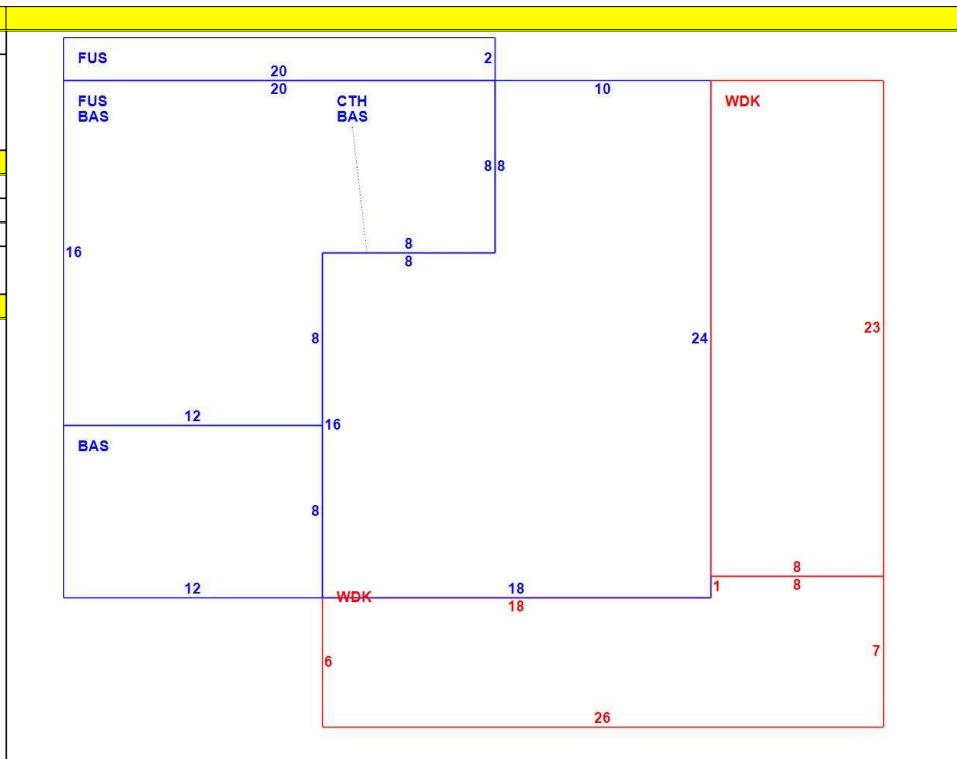

OB - OUTBUILDING & YARD ITEMS(L) / XF - BUILDING EXTRA FEATURES(B)										
Code	Description	L/B	Units	Unit Price	Yr Blt	Cond. Cd	% Gd	Grade	Grade Adj.	Appr. Value
SHD1	SHED FRAME	L	96	16.00	2016		100		0.00	1,500

BUILDING SUB-AREA SUMMARY SECTION						
Code	Description	Living Area	Floor Area	Eff Area	Unit Cost	Undeprec Value
BAS	First Floor	720	720	720	336.82	242,510
CTH	Cath Cing	0	368	18	16.47	6,063
FUS	Upper Story, Finished	296	296	296	336.82	99,699
WDK	Deck, Wood	0	348	35	33.88	11,789
Ttl Gross Liv / Lease Area		1,016	1,732	1,069		360,061

