

CURRENT OWNER		TOPO	UTILITIES	STRT / ROAD	LOCATION	CURRENT ASSESSMENT																
DENERO MARY C & SILVER WILLIAM 25 SEAVIEW DR			2 Public Water			Description	Code	Appraised	Assessed													
						RESIDENTL	1010	557,100	557,100													
PLYMOUTH MA 02360		SUPPLEMENTAL DATA				RES LND	1010	317,500	317,500													
		Alt Prcl ID PLN#/Rec Lot# Plan Notes Plan Notes Plan Notes GIS ID M_277743_794798	Restriction Hist Distrct Other Note UC-Misc 1 UC-Misc 2 Assoc Pid#			Total		874,600	874,600													
RECORD OF OWNERSHIP		BK-VOL/PAGE	SALE DATE	Q/U	V/I	SALE PRICE	VC	PREVIOUS ASSESSMENTS (HISTORY)														
DENERO MARY C &		1466 0931	05-08-2018	U	I	1	1A	Year	Code	Assessed	Year	Code	Assessed	Year	Code	Assessed						
DENERO MARY C		1291 1004	09-12-2012	Q	I	450,000	00	2023	1010	524,700	2022	1010	329,800	2021	1010	305,400						
SILVER WILLIAM--TRS		0616 0429	10-14-1993	U	I	63,000	1L		1010	347,900		1010	332,700		1010	330,000						
RESOLUTION TRUST CORPORATION		0592 0092	11-03-1992	U	I	146,200	1L															
LARRABEE BRIAN, SWIFT. MAURA.		0515 0360	02-01-1989	U	V	0	1	Total		872,600	Total		662,500	Total		635,400						
EXEMPTIONS			OTHER ASSESSMENTS				This signature acknowledges a visit by a Data Collector or Assessor															
Year	Code	Description	Amount	Code	Description	Number	Amount	Comm Int														
Total		0.00																				
ASSESSING NEIGHBORHOOD																						
Nbhd		Nbhd Name		B		Tracing		Batch														
0045																						
NOTES																						
CONTIG TO 11-1.244 LT 45 COUNTRY ACRS CF 205 NATURAL IA																						
BUILDING PERMIT RECORD																						
Permit Id	Issue Date	Type	Description	Amount	Insp Date	% Comp	Date Comp	Comments					Date	Id	Type	Is	Cd	Purpost/Result				
																	08-22-2022	EH		6	01	Cyclical Reinspection
																	05-25-2022	DM			11	Field Review
																	05-25-2017	AU			11	Field Review
																	11-15-2011	RK			11	Field Review
																	04-21-2004	JB			01	Cyclical Reinspection
																	04-01-1980					
LAND LINE VALUATION SECTION																						
B	Use Code	Description	Zone	Land Type	Land Units	Unit Price	Size Adj	Site Index	Cond.	Nbhd.	Nbhd. Adj	Notes	Location Adjustment	Adj Unit P	Land Value							
1	1010	SINGL FAM M-0	R60		21,827 SF	14.55	1.00000	4	1.00	0045	1.000			14.55	317,500							
Total Card Land Units					0.50	AC	Parcel Total Land Area					0.50	Total Land Value			317,500						

VISION

1302
EDGARTOWN, MA

CONSTRUCTION DETAIL			CONSTRUCTION DETAIL (CONTINUED)		
Element	Cd	Description	Element	Cd	Description
Style:	04	Cape Cod			
Model	01	Residential			
Grade:	04	Above Ave			
Stories:	1.5	1 1/2 Stories			
Occupancy	1				
Exterior Wall 1	11	Clapboard			
Exterior Wall 2					
Roof Structure:	03	Gable/Hip			
Roof Cover	03	Asph/F Gls/Cmp			
Interior Wall 1	05	Drywall/Sheet			
Interior Wall 2					
Interior Flr 1	12	Hardwood			
Interior Flr 2	14	Carpet			
Heat Fuel	04	Electric			
Heat Type:	07	Electr Basebrd			
AC Type:	01	None			
Total Bedrooms	04	4 Bedrooms			
Total Bthrms:	2				
Total Half Baths	0				
Total Xtra Fixtrs	7				
Total Rooms:	7				
Bath Style:	02	Average			
Kitchen Style:	02	Modern			
CONDO DATA					
Parcel Id		C		Owne	0.0
				B	S
Adjust Type	Code	Description	Factor%		
Condo Flr					
Condo Unit					
COST / MARKET VALUATION					
Building Value New		619,036			
Year Built		1989			
Effective Year Built		2012			
Depreciation Code		G			
Remodel Rating					
Year Remodeled					
Depreciation %		10			
Functional Obsol		0			
External Obsol		0			
Trend Factor		1			
Condition					
Condition %					
Percent Good		90			
Cns Sect Rcnld		557,100			
Dep % Ovr					
Dep Ovr Comment					
Misc Imp Ovr					
Misc Imp Ovr Comment					
Cost to Cure Ovr					
Cost to Cure Ovr Comment					

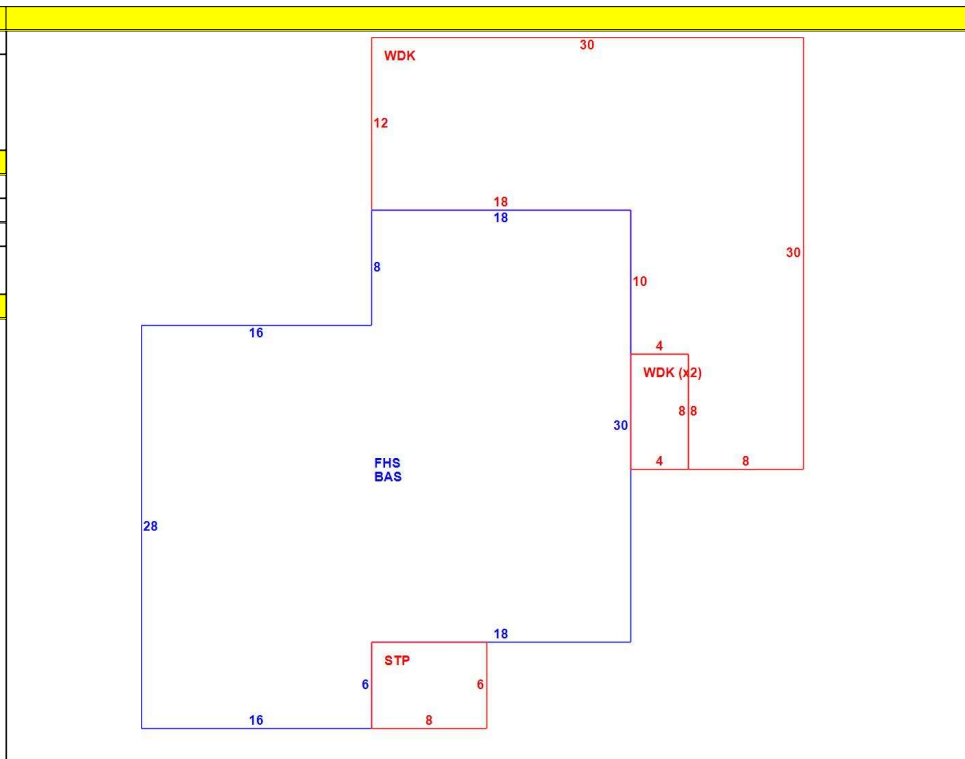

OB - OUTBUILDING & YARD ITEMS(L) / XF - BUILDING EXTRA FEATURES(B)										
Code	Description	L/B	Units	Unit Price	Yr Blt	Cond. Cd	% Gd	Grade	Grade Adj.	Appr. Value

BUILDING SUB-AREA SUMMARY SECTION							
Code	Description	Living Area	Floor Area	Eff Area	Unit Cost	Undeprec Value	
BAS	First Floor	988	988	988	396.34	391,585	
FHS	Half Story, Finished	494	988	494	198.17	195,792	
STP	Stoop	0	48	5	41.29	1,982	
WDK	Deck, Wood	0	608	61	39.76	24,177	
Ttl Gross Liv / Lease Area		1,482	2,632	1,548		613,536	

