

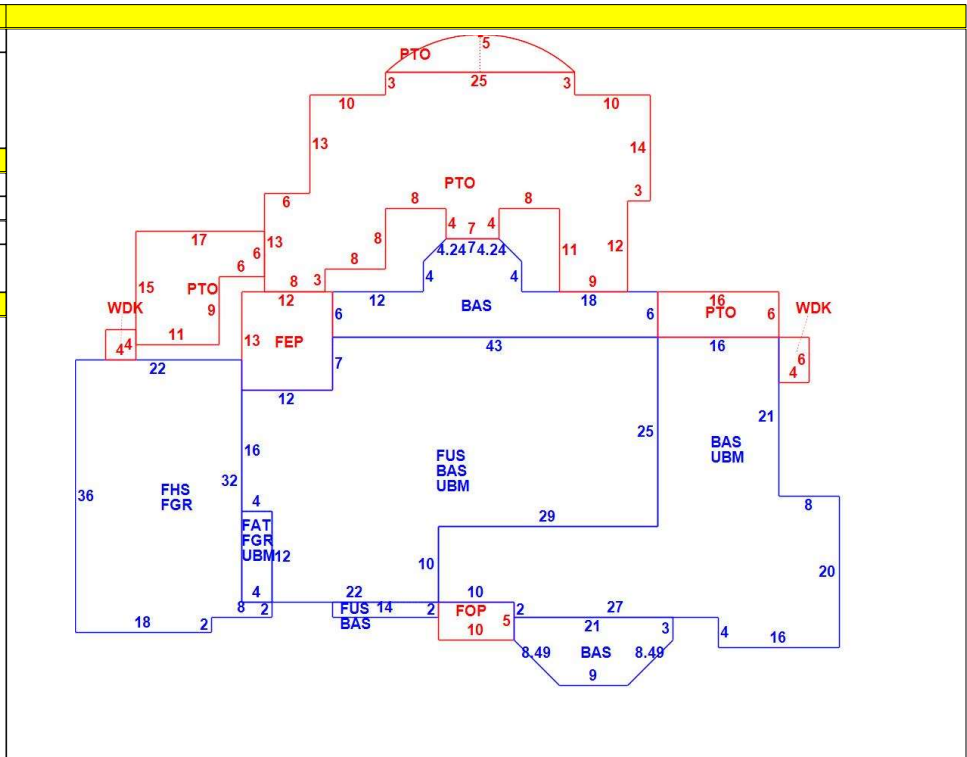

CONSTRUCTION DETAIL			CONSTRUCTION DETAIL (CONTINUED)		
Element	Cd	Description	Element	Cd	Description
Style:	06	Custom			
Model	01	Residential			
Grade:	09	Excellent			
Stories:	2	2 Stories			
Occupancy	1				
Exterior Wall 1	14	Wood Shingle			
Exterior Wall 2					
Roof Structure:	03	Gable/Hip			
Roof Cover	03	Asph/F Gls/Cmp			
Interior Wall 1	05	Drywall/Sheet			
Interior Wall 2	06	Cust Wd Panel			
Interior Flr 1	12	Hardwood			
Interior Flr 2	15	Quarry Tile			
Heat Fuel	03	Gas			
Heat Type:	04	Forced Air-Duc			
AC Type:	02	Heat Pump			
Total Bedrooms	04	4 Bedrooms			
Total Bthrms:	4				
Total Half Baths	1				
Total Xtra Fixtrs	1				
Total Rooms:	9	9 Rooms			
Bath Style:	02	Average			
Kitchen Style:	02	Modern			
<b>CONDO DATA</b>					
Parcel Id		C	Owne		0.0
		B	S		
Adjust Type	Code	Description	Factor%		
Condo Flr					
Condo Unit					
<b>COST / MARKET VALUATION</b>					
Building Value New		4,944,085			
Year Built		1993			
Effective Year Built		2016			
Depreciation Code		VG			
Remodel Rating					
Year Remodeled					
Depreciation %		5			
Functional Obsol		0			
External Obsol		0			
Trend Factor		1			
Condition					
Condition %		95			
Pcnt Sect Rcnld		4,696,900			
Dep % Ovr					
Dep Ovr Comment					
Misc Imp Ovr					
Misc Imp Ovr Comment					
Cost to Cure Ovr					
Cost to Cure Ovr Comment					



OB - OUTBUILDING & YARD ITEMS(L) / XF - BUILDING EXTRA FEATURES(B)										
Code	Description	L/B	Units	Unit Price	Yr Blt	Cond. Cd	% Gd	Grade	Grade Adj.	Appr. Value
FPL3	FPL MSNRY 2	B	1	4000.00	2006		95		0.00	3,800
FPL3	FPL MSNRY 2	B	1	4000.00	2006		95		0.00	3,800
FPO	EXTRA FPLO	B	1	800.00	2006		95		0.00	800
ODS	OUTDOOR S	L	2	700.00			100		0.00	1,400
SHD1	SHED FRAME	L	168	16.00	2016		100		0.00	2,700
PERG	PERGOLA	L	319	40.00	2019		100		0.00	12,800
PAT2	PATIO-GOOD	L	290	7.00	2019		100		0.00	2,000
SPL3	INGR GUNITE	L	800	100.00	2019		100		0.00	80,000

BUILDING SUB-AREA SUMMARY SECTION						
Code	Description	Living Area	Floor Area	Eff Area	Unit Cost	Undeprec Value
BAS	First Floor	3,136	3,136	3,136	790.93	2,480,363
FAT	Attic, Finished	10	48	10	164.78	7,909
FEP	Porch, Enclosed, Finished	0	156	109	552.64	86,212
FGR	Garage	0	840	336	316.37	265,753
FHS	Half Story, Finished	396	792	396	395.47	313,209
FOP	Porch, Open, Finished	0	50	10	158.19	7,909
FUS	Upper Story, Finished	1,531	1,531	1,531	790.93	1,210,917
PTO	Patio	0	1,421	142	79.04	112,312
UBM	Basement, Unfinished	0	2,663	533	158.31	421,567
WDK	Deck Wood	0	40	4	79.09	3,164
Ttl Gross Liv / Lease Area		5,073	10,677	6,207		4,909,315

