

Key: 1032

Town of SCITUATE - Fiscal Year 2024

10/18/2023 5:31 pm SEQ #: 985

LEGAL

LAND

DETACHED

BUILDING

CURRENT OWNER				PARCEL ID				LOCATION			
LACKEY RONALD 119 FIRST PARISH RD SCITUATE, MA 02066				49-1-29-0				119 FIRST PARISH RD			
TRANSFER HISTORY				DOS	T	SALE PRICE	BK-PG (Cert)				
LACKEY RONALD				11/07/2016	O	384,500	47711-287				
HOWARD RYAN &				06/05/2013	QS	352,500	43161-122				
SCHULTZ DOUGLAS S &				04/30/2004	QS	345,000	28096-19				

CLASS	CLASS%	DESCRIPTION			BN ID	BN	CARD	
1010	100	SINGLE FAMILY				1	1 of 1	
PMT NO	PMT DT	TY	DESC	AMOUNT	INSP	BY	1st	%
16-803	12/28/2016	2	ADDITIONS	40,000	08/03/2017	SJ	100	100
99-127	04/08/1999	3	ALTERATIONS				100	100
91-227	06/04/1991	3	ALTERATIONS				100	100

CD	T	AC/SF/UN	Ngh	Inf1	Inf2	ADJ BASE	SAF	Inf3	Lpi	VC	CREDIT AMT	ADJ VALUE	
100	S	10,000	SC 1.00	100	1.00	100	1.00	396,000	3.58	100	1.00	R02 0.90	325,070

TOTAL	10,000 SF	ZONING	FRNT	101	ASSESSED	CURRENT	PREVIOUS
Ngh	SCITUATE	NOTE			LAND	325,100	311,900
Inf1	FACTOR 100		BUILDING	430,900	383,200		
Inf2	PHY 100		DETACHED	0	0		
			OTHER	0	0		
			TOTAL	756,000	695,100		

TY	QUAL	COND	DIM/NOTE	YB	UNITS	ADJ PRICE	RCNLD



BLDG COMMENTS

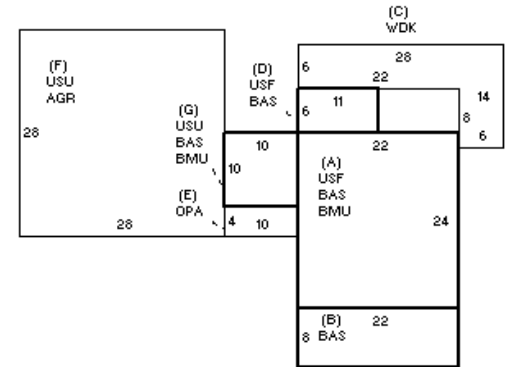

BUILDING	CD	ADJ	DESC	MEASURE	3/5/2013	SJ
MODEL	1		RESIDENTIAL	LIST	3/5/2013	EST
STYLE	7	1.20	CONVENTIONAL [100%]	REVIEW	3/11/2011	KT
QUALITY	A	1.00	AVERAGE [100%]			
FRAME	1	1.00	WOOD FRAME [100%]			

YEAR BLT	1918	SIZE ADJ	1.000	ELEMENT	CD	DESCRIPTION	ADJ	S	BAT	T	DESCRIPTION	UNITS	YB	ADJ PRICE	RCN	
NET AREA	1,464	DETAIL ADJ	1.224	FOUNDATION	4	CONT BSMT WALL	1.00	+	BMU	N	BSMT UNFINISHED	628		55.15	34,635	
\$NLA(RCN)	\$350	OVERALL	1.000	EXT COVER	2	CLAPBOARD	1.00	+	USF	L	UPPER STORY FIN	594	1918	218.22	129,620	
CAPACITY				ROOF SHAPE	1	GABLE	1.00	+	BAS	L	BASE AREA	770	1918	239.96	184,768	
STORIES	2		1.00	ROOF COVER	1	ASPH SHINGLES	1.00	C	WDK	N	WOOD DECK	216		38.40	8,294	
ROOMS	7		1.00	FLOOR COVER	99	N/A	1.00	E	OPA	N	OPEN PORCH	40		51.50	2,060	
BEDROOMS	3		1.00	INT FINISH	99	N/A	1.00	F	AGR	N	ATT GARAGE	784		40.09	31,428	
BATHROOMS	1		1.00	HEATING/COOLING	2	HOT WATER	1.02	+	USU	N	UPPER STORY UNF	884		96.19	85,030	
# 1/2 BATHS	1		1.00	FUEL SOURCE	2	GAS	1.00	G	BAS	L	BASE AREA	100	2017	239.96	23,996	
TOT FIXTURES	5	\$4,896							F21	O	FPL 2S 1OP	1		8,239.00	8,239	
# UNITS	1	1.00														

TOTAL RCN	512,966
CONDITION ELEM	CD
EXTERIOR	V
INTERIOR	V
KITCHEN	V
BATHS	V
HEAT	
ELECT	
EFF.YR/AGE	2006 / 16
COND	16 16%
FUNC	0
ECON	0
DEPR	16 % GD 84
RCNLD	\$430,900