

Key: 10725

Town of SCITUATE - Fiscal Year 2024

10/18/2023 5:31 pm SEQ #: 8.375

LEGAL

Table with columns: CURRENT OWNER, PARCEL ID, LOCATION, TRANSFER HISTORY, DOS, T, SALE PRICE, BK-PG (Cert). Includes owner GIANINNO LAWRENCE J & SUSAN M and parcel 71-6-5-A at 24 LOWELL ST.

Table with columns: CLASS, CLASS%, DESCRIPTION, BN ID, BN, CARD. Includes a table for PMT NO, PMT DT, TY, DESC, AMOUNT, INSP, BY, 1st, %.

LAND

Table with columns: CD, T, AC/SF/UN, Ngh, Inf1, Inf2, ADJ BASE, SAF, Inf3, Lpi, VC, CREDIT AMT, ADJ VALUE. Includes a summary table for TOTAL, ASSESSED, CURRENT, PREVIOUS.

DETACHED

Table with columns: TY, QUAL, COND, DIM/NOTE, YB, UNITS, ADJ PRICE, RCNLD. Includes a photo of the house and a table for BLDG COMMENTS.

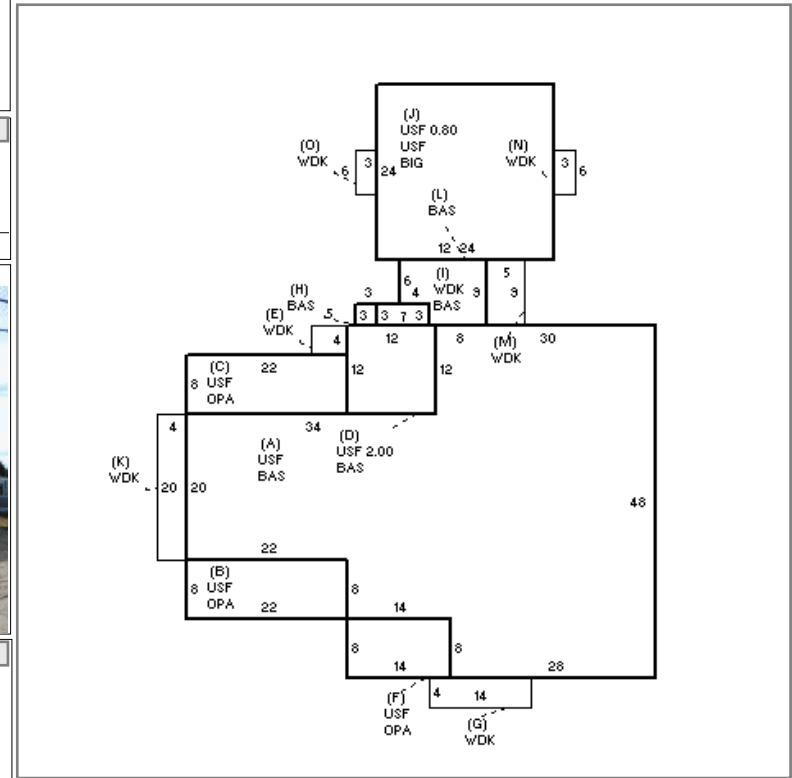

BUILDING

Table with columns: BUILDING, CD, ADJ, DESC, MEASURE, 9/6/2012, SJ, LIST, 9/6/2012, EST, REVIEW, 3/2/2011, ER.

Table with columns: BLDG COMMENTS, FY12 FR- CONV TO NEW STYLE.

INDIN

Main summary table with columns: YEAR BLT, NET AREA, \$NLA(RCN), CAPACITY, UNITS, ADJ, ELEMENT, CD, DESCRIPTION, ADJ, S, BAT, T, DESCRIPTION, UNITS, YB, ADJ PRICE, RCN, TOTAL RCN, CONDITION ELEM, CD, EFF. YR/AGE, COND, FUNC, ECON, DEPR, RCNLD.