

Key: 10899

Town of SCITUATE - Fiscal Year 2024

10/18/2023 5:31 pm SEQ #: 8.420

LEGAL

CURRENT OWNER				PARCEL ID				LOCATION				
FRASER IAIN & LINDA 64 INDIAN WIND DR SCITUATE, MA 02066				10-1-7-C				64 INDIAN WIND DR				
TRANSFER HISTORY				DOS	T	SALE PRICE	BK-PG (Cert)					
FRASER IAIN & LINDA				06/14/2018	QS	850,000	49916-222					
PEARSON JAMES T & IVY H				06/23/2016	QS	772,200	47090-250					
OLEKSIK STEPHEN A & WEND				06/10/2005	QS	960,000	30696-2					
CD	T	AC/SF/UN	Ngh	Inf1	Inf2	ADJ BASE	SAF	Inf3	Lpi	VC	CREDIT AMT	ADJ VALUE
100	S	40,000	WS 1.00	100	1.00	440,000	1.00	100	1.00	R05	1.00	404,040
300	A	0.312	WS 1.00	100	1.00	19,800	1.00	100	1.00	R05	1.00	6,180

LAND

TOTAL	1.230 Acres	ZONING	FRNT	102	ASSESSED	CURRENT	PREVIOUS
Ngh	W. SCITUATE	NOTE	LAND	410,200	373,200		
Inf1	FACTOR 100		BUILDING	783,700	725,400		
Inf2	PHY 100		DETACHED	1,700	1,600		
			OTHER	0	0		
TOTAL				1,195,600	1,100,200		

DETACHED

TY	QUAL	COND	DIM/NOTE	YB	UNITS	ADJ PRICE	RCNLD
SHF	A	1.00	10 0.90	14 X 10	140	13.34	1,700



BUILDING

BUILDING	CD	ADJ	DESC	MEASURE	3/26/2019	JD
MODEL	1		RESIDENTIAL	LIST	3/26/2019	EST
STYLE	5	1.00	COLONIAL [100%]	REVIEW	3/2/2011	ER
QUALITY	G	1.20	GOOD [100%]			
FRAME	1	1.00	WOOD FRAME [100%]			

BLDG COMMENTS
Extra Shower
Check M/S - bmt, kit

CLASS	CLASS%	DESCRIPTION		BN ID	BN	CARD		
1010	100	SINGLE FAMILY			1	1 of 1		
PMT NO	PMT DT	TY	DESC	AMOUNT	INSP	BY	1st	%
03-161	04/16/2003	6	CYCL GROWTH		03/26/2004	PJB	100	100
02-619	10/21/2002	3	ALTERATIONS				100	100
	10/01/1993	1	NEW CONST				100	100
		6	CYCL GROWTH				100	100

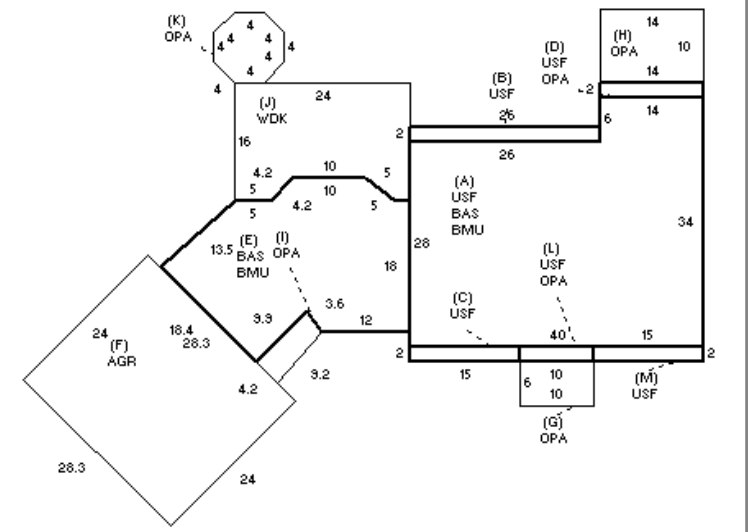

YEAR BLT	1995	SIZE ADJ	1.000
NET AREA	3,144	DETAIL ADJ	1.050
\$NLA(RCN)	\$287	OVERALL	1.000
CAPACITY		UNITS	ADJ
STORIES	2	1.00	
ROOMS	9	1.00	
BEDROOMS	5	1.00	
BATHROOMS	3	1.00	
# 1/2 BATHS	1	1.00	
TOT FIXTURES	13	\$13,104	
# UNITS	1	1.00	

ELEMENT	CD	DESCRIPTION	ADJ	S	BAT	T	DESCRIPTION	UNITS	YB	ADJ PRICE	RCN
FOUNDATION	4	CONT BSMT WALL	1.00	+	BMU	N	BSMT UNFINISHED	1,780		49.51	88,127
EXT COVER	2	CLAPBOARD	1.00	+	BAS	L	BASE AREA	1,780	1995	236.92	421,722
ROOF SHAPE	1	GABLE	1.00	+	USF	L	UPPER STORY FIN	1,364	1995	215.46	293,881
ROOF COVER	2	WOOD SHINGLES	1.01	+	OPA	N	OPEN PORCH	362		61.80	22,372
FLOOR COVER	13	COMB	1.00	F	AGR	N	ATT GARAGE	680		49.43	33,611
INT FINISH	2	DRYWALL	1.00	J	WDK	N	WOOD DECK	344		46.08	15,852
HEATING/COOLING	11	HW/COOL AIR	1.04	FPL	O		FIREPLACE	1		9,375.60	9,376
FUEL SOURCE	99	N/A	1.00	WPL	O		WHIRLPOOL-ADD	1		2,758.80	2,759

TOTAL RCN	900,803
CONDITION ELEM	CD
EXTERIOR	G
INTERIOR	G
KITCHEN	V
BATHS	G
HEAT	A
ELECT	A
EFF.YR/AGE	2009 / 13
COND	13 13 %
FUNC	0
ECON	0
DEPR	13 % GD 87
RCNLD	\$783,700