

Key: 10902

Town of SCITUATE - Fiscal Year 2024

10/18/2023 5:31 pm SEQ #: 8.423

LEGALS

CURRENT OWNER				PARCEL ID				LOCATION			
SANDBLOM ELIZABETH W TR & PETER R TR				13-2-32-0				16 MORDECAI LINCOLN RD			
16 MORDECAI LINCOLN RD SCITUATE, MA 02066				TRANSFER HISTORY				DOS	T	SALE PRICE	BK-PG (Cert)
				SANDBLOM ELIZABETH W TR & SANDBLOM ELIZABETH W, T				09/19/2019	F	100	51660-201
				SANDBLOM PETER ELIZ W				09/19/2019	F	100	51660-193
								09/06/2001	P	739,000	20498-257

CLASS	CLASS%	DESCRIPTION		BN ID	BN	CARD		
1010	100	SINGLE FAMILY			1	1 of 1		
PMT NO	PMT DT	TY	DESC	AMOUNT	INSP	BY	1st	%
01-672	11/26/2001	2	ADDITIONS				100	100
94-592	11/23/1994	2	ADDITIONS				100	100
		6	CYCL GROWTH				100	100

LAND

CD	T	AC/SF/UN	Ngh	Inf1	Inf2	ADJ BASE	SAF	Inf3	Lpi	VC	CREDIT AMT	ADJ VALUE
100	S	40,000	NS 1.00	100	1.00	374,000	1.00	100	1.00	R03	0.85	343,430
300	A	0.442	NS 1.00	100	1.00	16,830	1.00	100	1.00	R03	0.85	7,440

DETACHED

TOTAL	1.360 Acres	ZONING	FRNT	276	ASSESSED	CURRENT	PREVIOUS
Ngh	NO. SCITUATE	NOTE	LAND	350,900	338,100		
Inf1	FACTOR 100		BUILDING	808,300	749,100		
Inf2	PHY 100		DETACHED	0	0		
			OTHER	0	0		
			TOTAL	1,159,200	1,087,200		

TY	QUAL	COND	DIM/NOTE	YB	UNITS	ADJ PRICE	RCNLD



BLDG COMMENTS

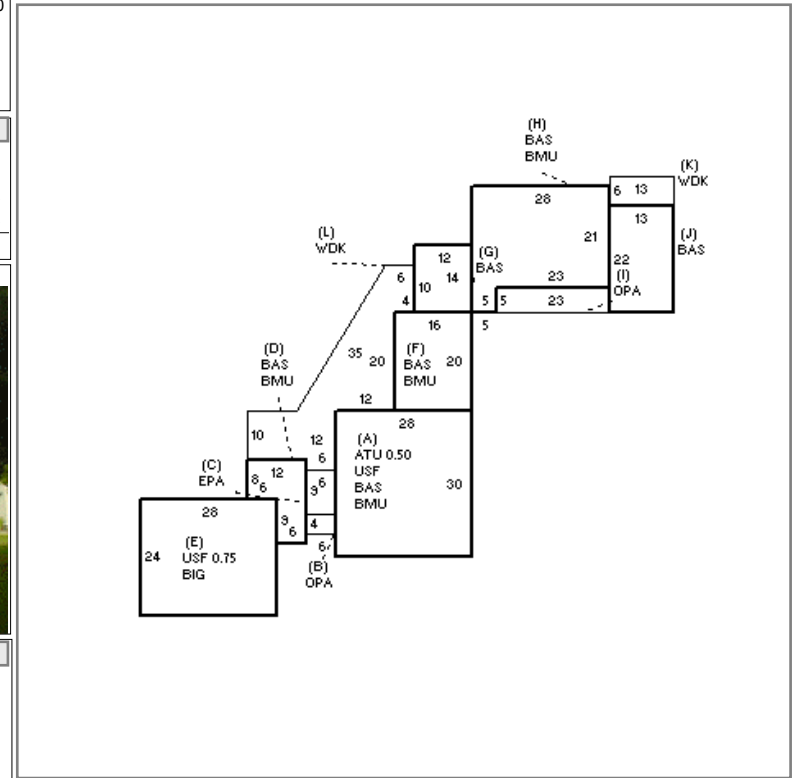

BUILDING

BUILDING	CD	ADJ	DESC	MEASURE	12/21/2010	PL
MODEL	1		RESIDENTIAL	LIST	12/21/2010	EST
STYLE	5	1.00	COLONIAL [100%]	REVIEW	3/1/2011	ER
QUALITY	G	1.20	GOOD [100%]			
FRAME	1	1.00	WOOD FRAME [100%]			

YEAR BLT	1994	SIZE ADJ	1.000	ELEMENT	CD	DESCRIPTION	ADJ	S	BAT	T	DESCRIPTION	UNITS	YB	ADJ PRICE	RCN	TOTAL RCN	1,023,106
NET AREA	3,721	DETAIL ADJ	1.020	FOUNDATION	4	CONT BSMT WALL	1.00	+	BMU	N	BSMT UNFINISHED	1,923		48.80	93,847		
\$NLA(RCN)	\$275	OVERALL	1.000	EXT COVER	2	CLAPBOARD	1.00	+	USF	L	UPPER STORY FIN	1,344	1994	205.31	275,938		
				ROOF SHAPE	1	GABLE	1.00	A	ATU	N	ATTIC UNF	420		44.40	18,648		
				ROOF COVER	1	ASPH SHINGLES	1.00	+	OPA	N	OPEN PORCH	139		61.80	8,591		
				FLOOR COVER	13	COMB	1.00	C	EPA	N	ENCLOSED PORCH	54		108.24	5,845		
				INT FINISH	2	DRYWALL	1.00	E	BIG	N	BUILT-IN GARAGE	672		50.52	33,952		
				HEATING/COOLING	2	HOT WATER	1.02	+	BAS	L	BASE AREA	2,377	1994	225.77	536,647		
				FUEL SOURCE	99	N/A	1.00	+	WDK	N	WOOD DECK	640		46.08	29,491		
									FPL	O	FIREPLACE	1		9,375.60	9,376		

CONDITION ELEM	CD
EXTERIOR	
INTERIOR	
KITCHEN	
BATHS	
HEAT	
ELECT	

EFF.YR/AGE	2000 / 22
COND	20 20 %
FUNC	0
ECON	0
DEPR	21 % GD 79
RCNLD	\$808,300