

Key: 11121

Town of SCITUATE - Fiscal Year 2024

10/18/2023 5:31 pm SEQ #: 8.583

LEG
AL
LAND

CURRENT OWNER				PARCEL ID				LOCATION				
MALAMUT SETH & ELIZABETH 100 PRATT RD SCITUATE, MA 02066				25-2-6-R				100 PRATT RD				
TRANSFER HISTORY				DOS	T	SALE PRICE	BK-PG (Cert)					
MALAMUT SETH & ELIZABETH				11/26/2019	QS	912,500	(129514)					
LEGGE BRYAN & MELANIE				07/30/2015	QS	750,000	(122206)					
MCCLUSKEY JOSEPH J JR & C				11/02/1998	P	419,215	(94396)					
CD	T	AC/SF/UN	Ngh	Inf1	Inf2	ADJ BASE	SAF	Inf3	Lpi	VC	CREDIT AMT	ADJ VALUE
100	S	40,000	NS 1.00	100	1.00	440,000	1.00	100	1.00	R04	1.00	404,040

CLASS	CLASS%	DESCRIPTION			BN ID	BN	CARD	
1010	100	SINGLE FAMILY				1	1 of 1	
PMT NO	PMT DT	TY	DESC	AMOUNT	INSP	BY	1st	%
18-416	07/10/2019	3	ALTERATIONS	20,000	07/10/2019	JD	100	100
18-416	06/29/2018	3	ALTERATIONS	20,000	07/19/2018	JD	100	0
17-142	03/22/2017	3	ALTERATIONS	41,500	06/30/2017	SJ	100	100
		6	CYCL GROWTH		09/23/2005		100	100
99-164	04/30/1999	3	ALTERATIONS				100	100

LAND

TOTAL	39,988 SF	ZONING	FRNT	78	ASSESSED	CURRENT	PREVIOUS
Ngh	NO. SCITUATE	NOTE			LAND	404,000	367,300
Inf1	FACTOR 100		BUILDING	704,400	660,900		
Inf2	PHY 100		DETACHED	12,000	11,400		
			OTHER	0	0		
					TOTAL	1,120,400	1,039,600

DE
TACH
ED

TY	QUAL	COND	DIM/NOTE	YB	UNITS	ADJ PRICE	RCNLD
IPG	A	1.00	30 0.70 26X14	2000	364	40.99	10,400
SHF	A	1.00	10 0.90 16X8		128	13.66	1,600

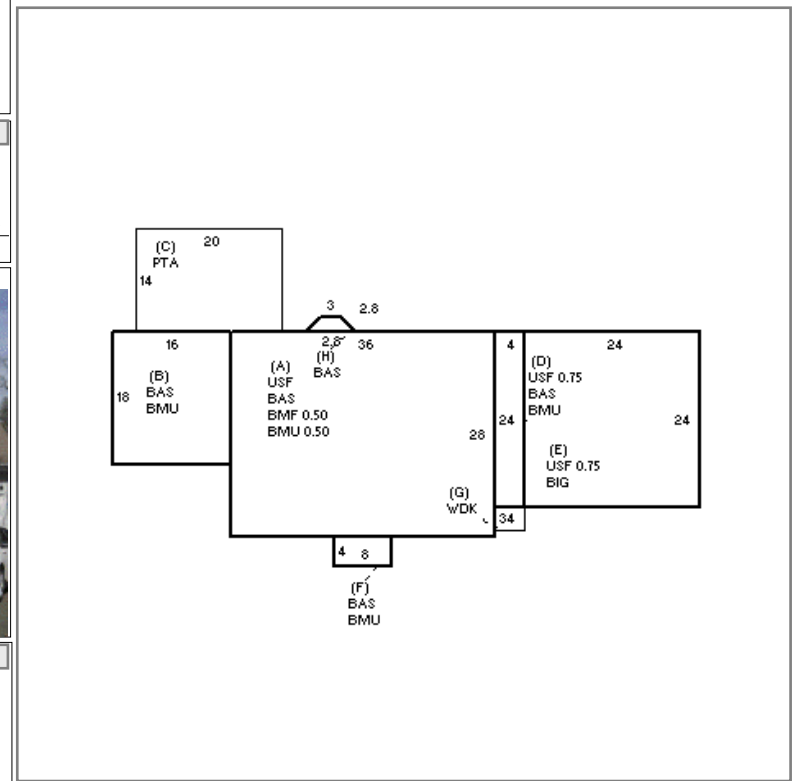

BU
ILD
ING

BUILDING	CD	ADJ	DESC	MEASURE	3/10/2020	JD
MODEL	1		RESIDENTIAL	LIST	3/10/2020	EST
STYLE	5	1.00	COLONIAL [100%]	REVIEW	7/10/2019	JD
QUALITY	+	1.10	AVG +/GOOD - [100%]			
FRAME	1	1.00	WOOD FRAME [100%]			

BLDG COMMENTS

YEAR BLT	1999	SIZE ADJ	1.000	ELEMENT	CD	DESCRIPTION	ADJ	S	BAT	T	DESCRIPTION	UNITS	YB	ADJ PRICE	RCN	TOTAL RCN	733,719	
NET AREA	2,946	DETAIL ADJ	1.030	FOUNDATION	4	CONT BSMT WALL	1.00	+	BMU	N	BSMT UNFINISHED	920		47.47	43,670	CONDITION ELEM	CD	
\$NLA(RCN)	\$249	OVERALL	1.000	EXT COVER	2	CLAPBOARD	1.00	A	BMF	N	BSMT FINISH-SEP	504		66.64	33,584	EXTERIOR	G	
				ROOF SHAPE	1	GABLE	1.00	+	USF	L	UPPER STORY FIN	1,512	1999	195.26	295,232	INTERIOR	G	
				ROOF COVER	1	ASPH SHINGLES	1.00	C	PTA	N	PATIO	280		16.39	4,589	KITCHEN	V	
				FLOOR COVER	13	COMB	1.00	E	BIG	N	BUILT-IN GARAGE	576		48.32	27,830	BATHS	G	
				INT FINISH	2	DRYWALL	1.00	G	WDK	N	WOOD DECK	12		42.26	507	HEAT	U	
				HEATING/COOLING	9	WARM/COOL AIR	1.03	+	BAS	L	BASE AREA	1,434	1999	214.71	307,900	ELECT	U	
				FUEL SOURCE	2	GAS	1.00		F11	O	FPL 1S 1OP	1		8,009.10	8,009			
										GEN	O	GENERATOR	1		0.00			
										ODS	O	OUT DOOR SHOWER	1		1,520.20	1,520		
														EFF.YR/AGE	2018 / 4			
														COND	4 4 %			
														FUNC	0			
														ECON	0			
														DEPR	4 % GD 96			
														RCNLD	\$704,400			