

Key: 11170

Town of SCITUATE - Fiscal Year 2024

10/18/2023 5:31 pm SEQ #: 8.630

LEGAL

LAND

DETACHED

BUILDING

CURRENT OWNER				PARCEL ID				LOCATION				
SANNELLA FRANK M & KRISTIN L 35 BEACH PLUM LN SCITUATE, MA 02066				44-3-26-0				35 BEACH PLUM LN				
TRANSFER HISTORY				DOS	T	SALE PRICE	BK-PG (Cert)					
SANNELLA FRANK M & KRISTI				08/21/2001	QS	620,000	20399-3					
HACKBARTH DAVID L & DEBOR				01/22/1998	QS	389,092	15825-37					
MCLAUGHLIN EDWARD J TRUST				12/19/1996	G2	460,000	14856-188					
CD	T	AC/SF/UN	Ngh	Inf1	Inf2	ADJ BASE	SAF	Inf3	Lpi	VC	CREDIT AMT	ADJ VALUE
100	S	23,457	SC	1.00	1.00	1.00	1.00	1.00	R05	1.10		420,920

CLASS	CLASS%	DESCRIPTION			BN ID	BN	CARD	
1010	100	SINGLE FAMILY				1	1 of 1	
PMT NO	PMT DT	TY	DESC	AMOUNT	INSP	BY	1st	%
22-1038	10/04/2022	3	ALTERATIONS	19,950	05/31/2023	NC	100	100
07-516	09/05/2007	3	ALTERATIONS		07/15/2008	SJ	100	100
04-491	07/29/2004	3	ALTERATIONS	8,000	07/05/2005	SJ	100	100
		6	CYCL GROWTH		01/15/2004	PJB	100	100
97-512	09/01/1997	1	NEW CONST				100	100

TOTAL	23,457 SF	ZONING		FRNT	126	ASSESSED	CURRENT	PREVIOUS
Ngh	SCITUATE	NOTE				LAND	420,900	382,700
Inf1	FACTOR 100		BUILDING	826,600	776,600			
Inf2	PHY 100		DETACHED	0	0			
			OTHER	0	0			
						TOTAL	1,247,500	1,159,300

TY	QUAL	COND	DIM/NOTE	YB	UNITS	ADJ PRICE	RCNLD	PHOTO	05/31/2023
									



BUILDING	CD	ADJ	DESC	MEASURE	12/21/2010	PL
MODEL	1		RESIDENTIAL	LIST	12/21/2010	EST
STYLE	5	1.00	COLONIAL [100%]	REVIEW	6/27/2023	NC
QUALITY	G	1.20	GOOD [100%]			
FRAME	1	1.00	WOOD FRAME [100%]			

YEAR BLT	1998	SIZE ADJ	1.000	ELEMENT	CD	DESCRIPTION	ADJ	S	BAT	T	DESCRIPTION	UNITS	YB	ADJ PRICE	RCN	TOTAL RCN	995,908
NET AREA	3,716	DETAIL ADJ	1.040	FOUNDATION	4	CONT BSMT WALL	1.00	+	BMU	N	BSMT UNFINISHED	1,046		51.38	53,742	CONDITION ELEM	CD
\$NLA(RCN)	\$268	OVERALL	1.000	EXT COVER	2	CLAPBOARD	1.00	A	BMF	N	BSMT FINISH-SEP	426		72.13	30,726	EXTERIOR	
				ROOF SHAPE	1	GABLE	1.00	A	ATU	N	ATTIC UNF	532		44.40	23,621	INTERIOR	
				ROOF COVER	1	ASPH SHINGLES	1.00	+	BAS	L	BASE AREA	1,634	1998	230.19	376,136	KITCHEN	
				FLOOR COVER	13	COMB	1.00	D	ATF	L	ATTIC FINISH	30	1998	148.72	4,462	BATHS	
				INT FINISH	2	DRYWALL	1.00	E	BIG	N	BUILT-IN GARAGE	864		49.26	42,559	HEAT	
				HEATING/COOLING	11	HW/COOL AIR	1.04	+	WDK	N	WOOD DECK	280		46.08	12,902	ELECT	
				FUEL SOURCE	1	OIL	1.00	I	OPA	N	OPEN PORCH	24		61.80	1,483		
								+	USF	L	UPPER STORY FIN	2,052	1998	209.34	429,558		
									F11	O	FPL 1S 1OP	1		8,737.20	8,737		

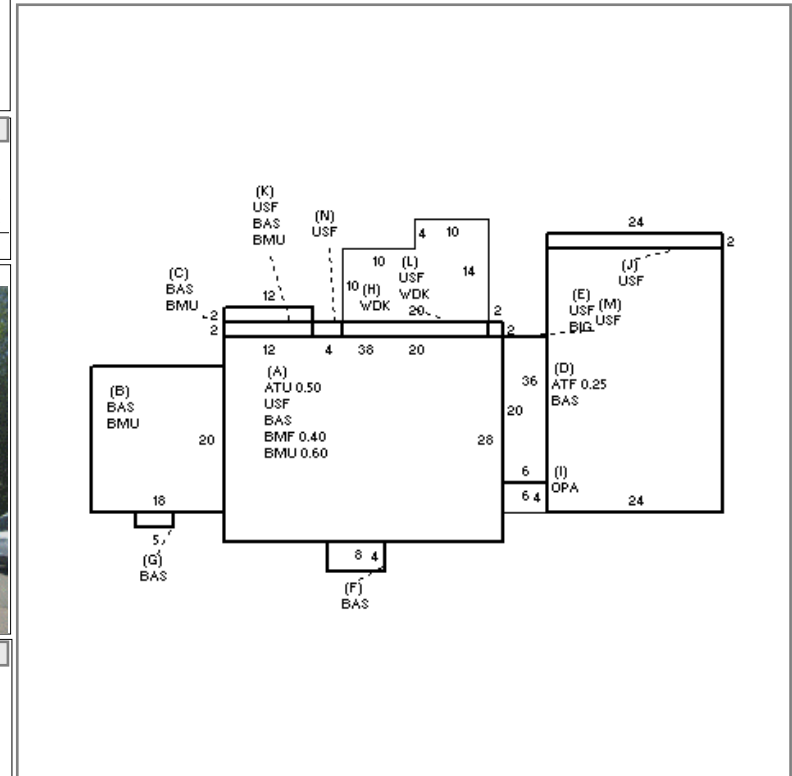

EFF.YR/AGE	2005 / 17
COND	17 17 %
FUNC	0
ECON	0
DEPR	17 % GD 83
RCNLD	\$826,600