

Key: 11713

Town of SCITUATE - Fiscal Year 2024

10/18/2023 5:31 pm SEQ #: 8.837

LEGAL

CURRENT OWNER				PARCEL ID				LOCATION				
WIZA ELIZABETH K 11 NORTHEY FARM RD SCITUATE, MA 02066				52-2-16-E				11 NORTHEY FARM RD				
TRANSFER HISTORY				DOS	T	SALE PRICE	BK-PG (Cert)					
WIZA ELIZABETH K				04/18/2014	H	10	44239-234					
WIZA JOSEPH C & ELIZABETH				09/08/2005	P	475,000	31300-154					
TEDESCHI JOHN				11/09/2001	P	500,000	20876-20					
CD	T	AC/SF/UN	Ngh	Inf1	Inf2	ADJ BASE	SAF	Inf3	Lpi	VC	CREDIT AMT	ADJ VALUE
100	S	32,640	WS 1.00	100	1.00	100	1.00		R06	1.40		552,740

LAND

TOTAL	32,640 SF	ZONING	FRNT	110	ASSESSED	CURRENT	PREVIOUS
Ngh	W. SCITUATE	NOTE			LAND	552,700	430,700
Inf1	FACTOR 100		BUILDING	1,035,600	898,600		
Inf2	PHY 100		DETACHED	25,800	24,500		
			OTHER	0	0		
TOTAL						1,614,100	1,353,800

DETACHED

TY	QUAL	COND	DIM/NOTE	YB	UNITS	ADJ PRICE	RCNLD
IPG	V	1.50	10 0.90	16 X 32	2006	512	55.91 25,800



BUILDING

BUILDING	CD	ADJ	DESC	MEASURE	10/16/2015	SJ
MODEL	1		RESIDENTIAL	LIST	10/16/2015	EST
STYLE	5	1.00	COLONIAL [100%]	REVIEW	2/28/2011	ER
QUALITY	V	1.40	VERY GOOD [100%]			
FRAME	1	1.00	WOOD FRAME [100%]			

BLDG COMMENTS
FY12 QUALITY CHANGE FROM EXC TO VG PER FIELD REVIEW.

CLASS	CLASS%	DESCRIPTION		BN ID	BN	CARD	
1010	100	SINGLE FAMILY			1	1 of 1	
PMT NO	PMT DT	TY	DESC	AMOUNT	INSP	BY	1st %
06-312	05/31/2006	6	CYCL GROWTH		04/26/2011		100 100
		1	NEW CONST		08/01/2007	SJ	0 0
06-312	05/31/2006	3	ALTERATIONS	26,000	08/16/2006	SJ	100 100
05-552	09/01/2005	1	NEW CONST	349,000	08/16/2006	SJ	100 100

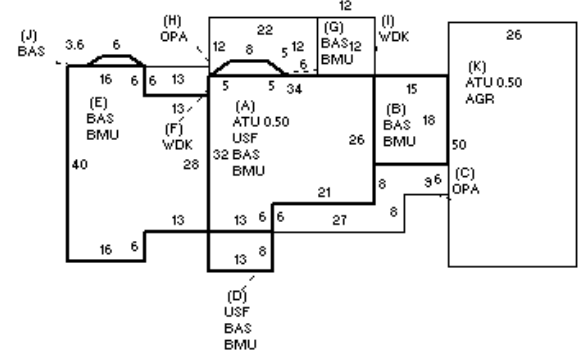

YEAR BLT	2006	SIZE ADJ	1.000
NET AREA	3,460	DETAIL ADJ	1.040
\$NLA(RCN)	\$356	OVERALL	1.000
CAPACITY		UNITS	ADJ
STORIES		2.5	1.00
ROOMS		10	1.00
BEDROOMS		4	1.00
BATHROOMS		4	1.00
# 1/2 BATHS		1	1.00
TOT FIXTURES		15	\$17,472
# UNITS		1	1.00

ELEMENT	CD	DESCRIPTION	ADJ
FOUNDATION	4	CONT BSMT WALL	1.00
EXT COVER	1	WD SHINGLES	1.00
ROOF SHAPE	1	GABLE	1.00
ROOF COVER	2	WOOD SHINGLES	1.01
FLOOR COVER	13	COMB	1.00
INT FINISH	2	DRYWALL	1.00
HEATING/COOLING	9	WARM/COOL AIR	1.03
FUEL SOURCE	99	N/A	1.00

S	BAT	T	DESCRIPTION	UNITS	YB	ADJ PRICE	RCN
+	BMU	N	BSMT UNFINISHED	2,376		55.11	130,939
+	USF	L	UPPER STORY FIN	1,066	2006	246.18	262,427
+	ATU	N	ATTIC UNF	1,131		51.80	58,586
+	OPA	N	OPEN PORCH	492		72.10	35,473
+	WDK	N	WOOD DECK	222		53.76	11,935
+	BAS	L	BASE AREA	2,394	2006	270.71	648,074
K	AGR	N	ATT GARAGE	1,300		52.23	67,901

TOTAL RCN	1,232,808
CONDITION ELEM CD	
EXTERIOR	
INTERIOR	
KITCHEN	
BATHS	
HEAT	
ELECT	
EFF.YR/AGE	2006 / 16
COND	16 16 %
FUNC	0
ECON	0
DEPR	16 % GD 84
RCNLD	\$1,035,600