

Key: 1182

Town of SCITUATE - Fiscal Year 2024

10/18/2023 5:31 pm SEQ #: 1.131

LEGAL

CURRENT OWNER				PARCEL ID				LOCATION			
KERNS DENNY S JR & LINDA D 158 CAPTAIN PEIRCE RD SCITUATE, MA 02066				26-2-44-0				158 CAPTAIN PEIRCE RD			
TRANSFER HISTORY				DOS	T	SALE PRICE	BK-PG (Cert)				
KERNS DENNY S JR & LINDA				11/02/2001	QS	410,000	20833-330				
THORNTON WILLIAM L & BARB				08/25/1998	QS	150,000	16534-254				
DUNPHY ROBERT B JR TRUSTE				05/22/1998	QS	120,000	16222-100				

CLASS	CLASS%	DESCRIPTION			BN ID	BN	CARD	
1010	100	SINGLE FAMILY				1	1 of 1	
PMT NO	PMT DT	TY	DESC	AMOUNT	INSP	BY	1st	%
98-208	11/01/1998	3	ALTERATIONS				100	100

LAND

CD	T	AC/SF/UN	Ngh	Inf1	Inf2	ADJ BASE	SAF	Inf3	Lpi	VC	CREDIT AMT	ADJ VALUE
100	S	21,530	SC	1.00	100	1.00	100	1.00	R03	0.90		341,960

TOTAL	21,530 SF	ZONING	FRNT	275	ASSESSED	CURRENT	PREVIOUS
Ngh	SCITUATE	NOTE ...Primary residence Naples FL	LAND	342,000	328,100		
Inf1	FACTOR 100		BUILDING	371,200	334,400		
Inf2	PHY 100		DETACHED	0	0		
			OTHER	0	0		
		TOTAL		713,200	662,500		

DETACHED

TY	QUAL	COND	DIM/NOTE	YB	UNITS	ADJ PRICE	RCNLD

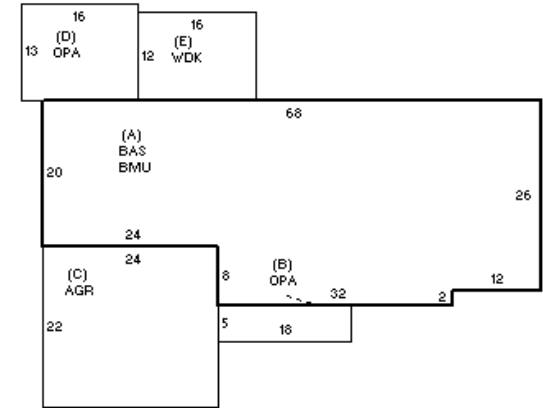

BUILDING

BUILDING	CD	ADJ	DESC	MEASURE	8/9/2010	PL
MODEL	1		RESIDENTIAL	LIST	8/9/2010	EST
STYLE	1	0.85	RANCH [100%]	REVIEW	3/15/2011	KT
QUALITY	+	1.10	AVG +/GOOD - [100%]			
FRAME	1	1.00	WOOD FRAME [100%]			

BLDG COMMENTS

G

YEAR BLT	1999	SIZE ADJ	1.000	ELEMENT	CD	DESCRIPTION	ADJ	S	BAT	T	DESCRIPTION	UNITS	YB	ADJ PRICE	RCN	TOTAL RCN	475.871
NET AREA	1,688	DETAIL ADJ	0.867	FOUNDATION	4	CONT BSMT WALL	1.00	A	BMU	N	BSMT UNFINISHED	1,688		45.85	77,389		
\$NLA(RCN)	\$282	OVERALL	1.000	EXT COVER	2	CLAPBOARD	1.00	A	BAS	L	BASE AREA	1,688	1999	198.83	335,622		
				ROOF SHAPE	1	GABLE	1.00	+	OPA	N	OPEN PORCH	298		56.65	16,882		
				ROOF COVER	1	ASPH SHINGLES	1.00	C	AGR	N	ATT GARAGE	528		47.88	25,280		
				FLOOR COVER	99	N/A	1.00	E	WDK	N	WOOD DECK	192		42.24	8,110		
				INT FINISH	99	N/A	1.00		F11	O	FPL 1S 1OP	1		8,009.10	8,009		
				HEATING/COOLING	2	HOT WATER	1.02										
				FUEL SOURCE	99	N/A	1.00										
CAPACITY		UNITS	ADJ														
STORIES		1	1.00														
ROOMS		6	1.00														
BEDROOMS		3	1.00														
BATHROOMS		2	1.00														
# 1/2 BATHS		0	1.00														
TOT FIXTURES		6	\$4,578														
# UNITS		1	1.00														
																CONDITION ELEM	CD
																EXTERIOR	
																INTERIOR	
																KITCHEN	
																BATHS	
																HEAT	
																ELECT	
																EFF.YR/AGE	1999 / 23
																COND	20 20 %
																FUNC	0
																ECON	0
																DEPR	22 % GD 78
																RCNLD	\$371,200