

Key: 1211

Town of SCITUATE - Fiscal Year 2024

10/18/2023 5:31 pm SEQ #: 1.159

LEGAL

LAND

DETACHED

BUILDING

CURRENT OWNER				PARCEL ID				LOCATION			
WHITE GEORGE B TR 110 CAPTAIN PEIRCE RD SCITUATE, MA 02066				26-3-8-A				110 CAPTAIN PEIRCE RD			
TRANSFER HISTORY				DOS	T	SALE PRICE	BK-PG (Cert)				
WHITE GEORGE B TR				03/18/2014	F		1 44155-210				
WHITE GEORGE B & JANICE D				07/31/2013	F		1 43427-171				
WHITE GEORGE B TRUSTEE				10/15/1996	F		1 14716-167				

CLASS	CLASS%	DESCRIPTION			BN ID	BN	CARD	
1010	100	SINGLE FAMILY				1	1 of 1	
PMT NO	PMT DT	TY	DESC	AMOUNT	INSP	BY	1st	%
89-625	11/14/1989	2	ADDITIONS				100	100

CD	T	AC/SF/UN	Ngh	Inf1	Inf2	ADJ BASE	SAF	Inf3	Lpi	VC	CREDIT AMT	ADJ VALUE
100	S	31,411	SC 1.00	100	1.00	396,000	1.24	100	1.00	R04 0.90		353,920

TOTAL	31,411 SF	ZONING	NOOTE	FRNT	110	ASSESSED	LAND 353,900 BUILDING 407,700 DETACHED 0 OTHER 0 TOTAL 761,600	CURRENT	339,600 383,200 0 0 722,800	PREVIOUS	339,600 383,200 0 0 722,800										
Ngh	SCITUATE	Inf1	FACTOR 100	Inf2	PHY 100	TY		QUAL		COND		DIM/NOTE		YB		UNITS		ADJ PRICE		RCNLD	

PHOTO 11/10/2022



BLDG COMMENTS

BUILDING	CD	ADJ	DESC	MEASURE	11/10/2022	JD
MODEL	1		RESIDENTIAL	LIST	11/10/2022	EST
STYLE	5	1.00	COLONIAL [100%]	REVIEW	3/16/2011	KT
QUALITY	A	1.00	AVERAGE [100%]			
FRAME	1	1.00	WOOD FRAME [100%]			

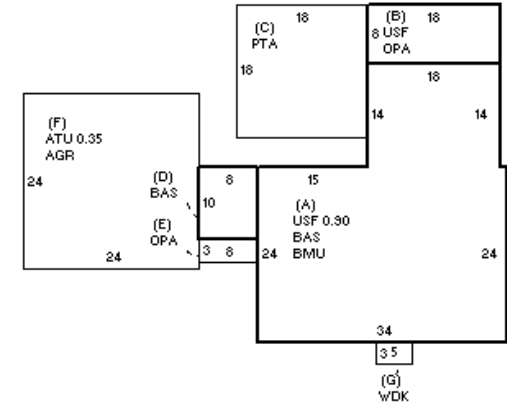

YEAR BLT	1976	SIZE ADJ	1.000	ELEMENT	CD	DESCRIPTION	ADJ	S	BAT	T	DESCRIPTION	UNITS	YB	ADJ PRICE	RCN	TOTAL RCN	543,597
NET AREA	2,253	DETAIL ADJ	1.020	FOUNDATION	4	CONT BSMT WALL	1.00	A	BMU	N	BSMT UNFINISHED	1,068		46.31	49,459	CONDITION ELEM	CD
\$NLA(RCN)	\$241	OVERALL	1.000	EXT COVER	2	CLAPBOARD	1.00	+	USF	L	UPPER STORY FIN	1,105	1976	183.02	202,237	EXTERIOR	A
CAPACITY			UNITS	ADJ	ROOF SHAPE	3	GAMBREL	1.00	+	OPA	N	OPEN PORCH	168	51.50	8,652	INTERIOR	G
STORIES	1.9	1.00	ROOF COVER	1	ASPH SHINGLES	1.00	C	PTA	N	PATIO	324		14.90	4,828	KITCHEN	G	
ROOMS	9	1.00	FLOOR COVER	24	COMB	1.00	+	BAS	L	BASE AREA	1,148	1976	201.26	231,041	BATHS	A	
BEDROOMS	4	1.00	INT FINISH	2	DRYWALL	1.00	F	AGR	N	ATT GARAGE	576		42.64	24,563	BATHS	A	
BATHROOMS	2	1.00	HEATING/COOLING	2	HOT WATER	1.02	F	ATU	N	ATTIC UNF	202		37.00	7,474	HEAT	A	
# 1/2 BATHS	1	1.00	FUEL SOURCE	2	GAS	1.00	G	WDK	N	WOOD DECK	15		38.40	576	ELECT	A	
TOT FIXTURES	8	\$6,528						F21	O	FPL 2S 1OP	1		8,239.00	8,239			
# UNITS	1	1.00															
																EFF.YR/AGE	1988 / 34
																COND	25 25 %
																FUNC	0
																ECON	0
																DEPR	25 % GD 75
																RCNLD	\$407,700