

Key: 1263

Town of SCITUATE - Fiscal Year 2024

10/18/2023 5:31 pm SEQ #: 1.209

LEGAL

CURRENT OWNER				PARCEL ID				LOCATION			
BAER RICHARD J & WENDY LEE				48-1-36-J				3 COLONIAL WAY			
3 COLONIAL WAY				TRANSFER HISTORY				DOS	T	SALE PRICE	BK-PG (Cert)
SCITUATE, MA 02066				BAER RICHARD J & WENDY LE				12/18/2002	QS	1	23716-288
				EATON WENDY LEE				06/27/1988	QS	50,000	8543-187
				EATON HARAVEY W & WENDY L				01/01/1977	XX		4152-592

CLASS	CLASS%	DESCRIPTION			BN ID	BN	CARD	
1010	100	SINGLE FAMILY				1	1 of 1	
PMT NO	PMT DT	TY	DESC	AMOUNT	INSP	BY	1st	%
02-442	08/06/2002	3	ALTERATIONS		02/18/2004	PJB	100	100
02-192	04/17/2002	3	ALTERATIONS				100	100

LAND

CD	T	AC/SF/UN	Ngh	Inf1	Inf2	ADJ BASE	SAF	Inf3	Lpi	VC	CREDIT AMT	ADJ VALUE
100	S	20,028	SC 1.00	100	1.00	396,000	1.87	100	1.00	R04	0.90	340,000

DETACHED

TOTAL	20,028 SF	ZONING	FRNT	268	ASSESSED	CURRENT	PREVIOUS
Ngh	SCITUATE	NOTE			LAND	340,000	326,300
Inf1	FACTOR 100		BUILDING	377,800	340,500		
Inf2	PHY 100		DETACHED	0	0		
			OTHER	0	0		
			TOTAL	717,800	666,800		

TY	QUAL	COND	DIM/NOTE	YB	UNITS	ADJ PRICE	RCNLD

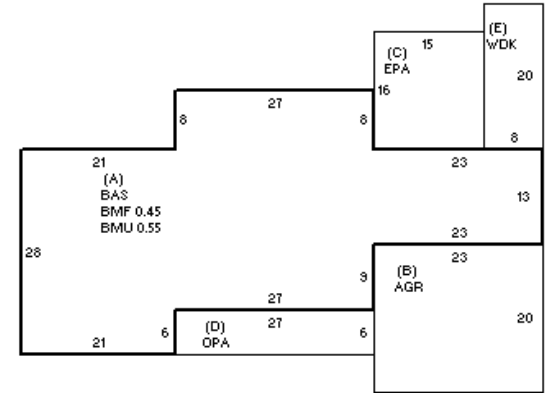

BUILDING

BUILDING	CD	ADJ	DESC	MEASURE	7/22/2009	PL
MODEL	1		RESIDENTIAL	LIST		
STYLE	1	0.85	RANCH [100%]	REVIEW	3/16/2011	KT
QUALITY	+	1.10	AVG +/GOOD - [100%]			
FRAME	1	1.00	WOOD FRAME [100%]			

BLDG COMMENTS

G

YEAR BLT	1965	SIZE ADJ	1.000	ELEMENT	CD	DESCRIPTION	ADJ	S	BAT	T	DESCRIPTION	UNITS	YB	ADJ PRICE	RCN	TOTAL RCN	503,724
NET AREA	1,697	DETAIL ADJ	0.867	FOUNDATION	4	CONT BSMT WALL	1.00	A	BMU	N	BSMT UNFINISHED	933		45.80	42,732		
\$NLA(RCN)	\$297	OVERALL	1.000	EXT COVER	1	WD SHINGLES	1.00	A	BMF	N	BSMT FINISH-SEP	764		64.30	49,122		
				ROOF SHAPE	1	GABLE	1.00	A	BAS	L	BASE AREA	1,697	1965	198.43	336,730		
				ROOF COVER	1	ASP SHINGLES	1.00	B	AGR	N	ATT GARAGE	460		49.58	22,805		
				FLOOR COVER	99	N/A	1.00	C	EPA	N	ENCLOSED PORCH	240		99.22	23,813		
				INT FINISH	99	N/A	1.00	D	OPA	N	OPEN PORCH	162		56.65	9,177		
				HEATING/COOLING	2	HOT WATER	1.02	E	WDK	N	WOOD DECK	160		42.24	6,758		
				FUEL SOURCE	99	N/A	1.00	F11	O		FPL 1S 1OP	1		8,009.10	8,009		
																CONDITION ELEM	CD
																EXTERIOR	
																INTERIOR	
																KITCHEN	
																BATHS	
																HEAT	
																ELECT	
																EFF.YR/AGE	1990 / 32
																COND	25 25 %
																FUNC	0
																ECON	0
																DEPR	25 % GD 75
																RCNLD	\$377,800