

Key: 141

Town of SCITUATE - Fiscal Year 2024

10/18/2023 5:31 pm SEQ #: 125

LEGAL

CURRENT OWNER				PARCEL ID				LOCATION			
MLADENOFF ELI & CLAUDIA E TRS 740 COUNTRY WAY SCITUATE, MA 02066				12-5-8-0				740 COUNTRY WAY			
TRANSFER HISTORY				DOS	T	SALE PRICE	BK-PG (Cert)				
MLADENOFF ELI & CLAUDIA E				04/12/2021	F	1	54771-117				
MLADENOFF ELI & CLAUDIA E				07/17/1986	QS	277,500	6949-327				
MUTHER GEOFFREY & DOUGLAS				10/21/1985	XX		6376-226				

CLASS	CLASS%	DESCRIPTION			BN ID	BN	CARD	
1010	100	SINGLE FAMILY				1	1 of 1	
PMT NO	PMT DT	TY	DESC	AMOUNT	INSP	BY	1st	%
		7	OTHERS		11/03/2022	JD	100	100

LAND

CD	T	AC/SF/UN	Ngh	Infl1	Infl2	ADJ BASE	SAF	Infl3	Lpi	VC	CREDIT AMT	ADJ VALUE
100	S	20,057	NS 1.00	100	1.00	374,000	1.86	100	1.00	R02	0.85	321,150

TOTAL	20,057 SF	ZONING	FRNT	130	ASSESSED	CURRENT	PREVIOUS
Ngh	NO. SCITUATE	NOTE			LAND	321,200	309,100
Infl1	FACTOR 100		BUILDING	418,100	231,500		
Infl2	PHY 100		DETACHED	0	0		
			OTHER	0	0		
			TOTAL		739,300	540,600	

DETACHED

TY	QUAL	COND	DIM/NOTE	YB	UNITS	ADJ PRICE	RCNLD

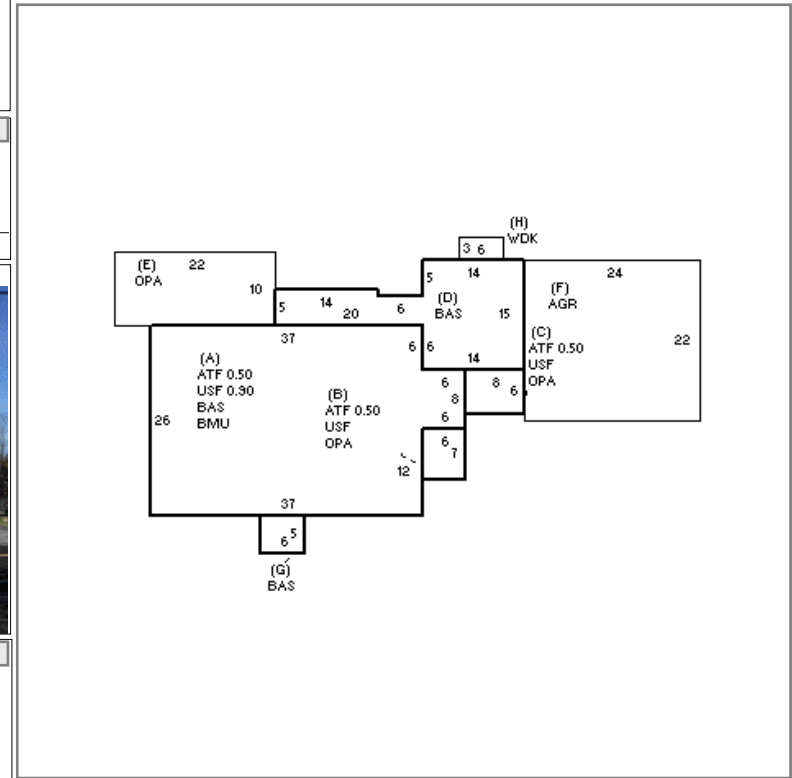

BUILDING

BUILDING	CD	ADJ	DESC	MEASURE	11/3/2022	JD
MODEL	1		RESIDENTIAL	LIST	11/3/2022	EST
STYLE	19	1.15	ANTIQUE [100%]	REVIEW	3/4/2011	KT
QUALITY	+	1.10	AVG +/GOOD - [100%]			
FRAME	1	1.00	WOOD FRAME [100%]			

BLDG COMMENTS
OTHER FIX=2 SINKS

INDING

YEAR BLT	1750	SIZE ADJ	1.000	ELEMENT	CD	DESCRIPTION	ADJ	S	BAT	T	DESCRIPTION	UNITS	YB	ADJ PRICE	RCN	TOTAL RCN	746,678
NET AREA	2,893	DETAIL ADJ	1.150	FOUNDATION	5	BRICK/STONE	1.00	A	BMU	N	BSMT UNFINISHED	1,010		51.73	52,246		
\$NLA(RCN)	\$258	OVERALL	1.000	EXT COVER	2	CLAPBOARD	1.00	+	USF	L	UPPER STORY FIN	999	1750	218.74	218,517		
				ROOF SHAPE	1	GABLE	1.00	+	ATF	L	ATTIC FINISH	550	1750	155.41	85,474		
				ROOF COVER	1	ASPH SHINGLES	1.00	+	OPA	N	OPEN PORCH	310		56.65	17,562		
				FLOOR COVER	24	COMB	1.00	+	BAS	L	BASE AREA	1,344	1750	240.53	323,271		
				INT FINISH	1	PLASTER	1.00	F	AGR	N	ATT GARAGE	528		47.88	25,280		
				HEATING/COOLING	1	FORCED AIR	1.00	H	WDK	N	WOOD DECK	18		42.23	760		
				FUEL SOURCE	2	GAS	1.00	F22	O	O	FPL 2S 2OP	1		12,435.50	12,436		
																CONDITION ELEM	CD
																EXTERIOR	F
																INTERIOR	F
																KITCHEN	F
																BATHS	F
																HEAT	A
																ELECT	A
																EFF.YR/AGE	1963 / 59
																COND	44 44 %
																FUNC	0
																ECON	0
																DEPR	44 % GD 56
																RCNLD	\$418,100