

Key: 1419

Town of SCITUATE - Fiscal Year 2024

10/18/2023 5:31 pm SEQ #: 1.366

LEG
AL
LAND

CURRENT OWNER				PARCEL ID				LOCATION				
KRAWIEC K R & CASTRO-KRAWIEC R				13-1-5-0				38 HOLLETT ST				
38 HOLLETT STREET				TRANSFER HISTORY				DOS	T	SALE PRICE	BK-PG (Cert)	
NORTH SCITUATE, MA 02066				KRAWIEC K R & CASTRO-KRAW				01/03/1994	QS	204,000	12558-162	
				DILLON JEFFREY & LUNDGREN				03/27/1989	QS	241,000	9050-288	
				LISNEK JAY L AND CONNEE				05/01/1985	XX	6077-53		

CLASS	CLASS%	DESCRIPTION			BN ID	BN	CARD	
1010	100	SINGLE FAMILY				1	1 of 1	
PMT NO	PMT DT	TY	DESC	AMOUNT	INSP	BY	1st	%
22-0617	06/10/2022	3	ALTERATIONS	24,200	11/07/2022	JD	100	100
16-137	03/29/2016	3	ALTERATIONS	27,600	06/08/2016	SJ	100	100
13-282	05/13/2013	2	ADDITIONS	40,000	06/20/2013	SJ	100	100
13-282	05/13/2013	2	ADDITIONS	40,000	06/11/2014	MR	100	100
		2	ADDITIONS		05/25/2006	SJ	100	100

CD	T	AC/SF/UN	Ngh	Inf1	Inf2	ADJ BASE	SAF	Inf3	Lpi	VC	CREDIT AMT	ADJ VALUE
100	S	17,500	NS 1.00	100	1.00	374,000	2.12	100	1.00	R02	0.85	317,900

TOTAL	17,511 SF	ZONING	FRNT	100	ASSESSED	CURRENT	PREVIOUS
Ngh	NO. SCITUATE	NOTE	LAND	317,900	306,000		
Inf1	FACTOR 100		BUILDING	455,000	404,600		
Inf2	PHY 100		DETACHED	1,000	200		
			OTHER	0	0		
			TOTAL	773,900	710,800		

TY	QUAL	COND	DIM/NOTE	YB	UNITS	ADJ PRICE	RCNLD
SHF	A	1.00	40 0.60 8X16		128	13.66	1,000

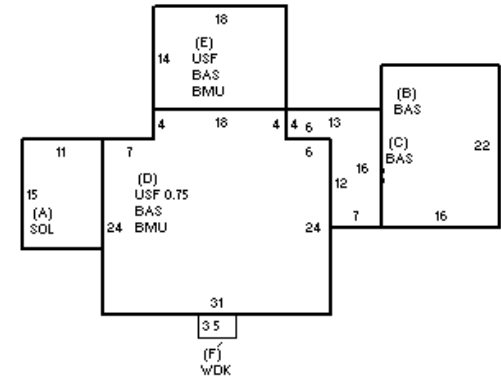

BLDG COMMENTS

DETACHED

BUILDING

BUILDING	CD	ADJ	DESC	MEASURE	11/7/2022	JD
MODEL	1		RESIDENTIAL	LIST	11/7/2022	EST
STYLE	4	1.10	CAPE [100%]	REVIEW	7/1/2014	TD
QUALITY	A	1.00	AVERAGE [100%]			
FRAME	1	1.00	WOOD FRAME [100%]			

YEAR BLT	1948	SIZE ADJ	1.000	ELEMENT	CD	DESCRIPTION	ADJ	S	BAT	T	DESCRIPTION	UNITS	YB	ADJ PRICE	RCN	TOTAL RCN	598,749	
NET AREA	2,585	DETAIL ADJ	1.122	FOUNDATION	4	CONT BSMT WALL	1.00	A	SOL	L	SOL/ 3 SEASON	165	1948	138.01	22,771	CONDITION ELEM	CD	
\$NLA(RCN)	\$232	OVERALL	1.000	EXT COVER	2	CLAPBOARD	1.00	+	BAS	L	BASE AREA	1,304	1948	218.78	285,288	EXTERIOR	G	
				ROOF SHAPE	1	GABLE	1.00	+	BMU	N	BSMT UNFINISHED	1,068		46.31	49,459	INTERIOR	G	
				ROOF COVER	1	ASPH SHINGLES	1.00	D	USF	L	UPPER STORY FIN	612	1948	198.96	121,761	KITCHEN	G	
				FLOOR COVER	24	COMB	1.00	E	BAS	L	BASE AREA	252	2005	218.78	55,132	BATHS	G	
				INT FINISH	1	PLASTER	1.00	E	USF	L	UPPER STORY FIN	252	2005	198.96	50,137	HEAT	A	
				HEATING/COOLING	2	HOT WATER	1.02	F	WDK	N	WOOD DECK	15		38.40	576	ELECT	A	
				FUEL SOURCE	1	OIL	1.00	F	F21	O	FPL 2S 1OP	1		8,239.00	8,239			
																	EFF.YR/AGE	1991 / 31
																	COND	25 25 %
																	FUNC	0
																	ECON	0
																	DEPR	24 % GD 76
																	RCNLD	\$455,000