

Key: 1580

Town of SCITUATE - Fiscal Year 2024

10/18/2023 5:31 pm SEQ #: 1.523

LEGAL

LAND

DETACHED

BUILDING

CURRENT OWNER				PARCEL ID				LOCATION			
O'MALLEY KEVIN M & CERYL C TRS 172 MANN LOT RD SCITUATE, MA 02066				25-5-12-0				172 MANN LOT RD			
TRANSFER HISTORY				DOS	T	SALE PRICE		BK-PG (Cert)			
O'MALLEY KEVIN M & CERYL				09/17/2021	F	1 55680-246					
O'MALLEY KEVIN M				04/29/2009	F	100 37127-209					
O'MALLEY KEVIN M &				12/23/2005	F	-100 31966-42					

CLASS	CLASS%	DESCRIPTION			BN ID	BN	CARD	
1010	100	SINGLE FAMILY				1	1 of 1	
PMT NO	PMT DT	TY	DESC	AMOUNT	INSP	BY	1st	%
117-731	11/14/2017	3	ALTERATIONS	4,200	03/29/2018	JD	100	100
17-628	09/28/2017	3	ALTERATIONS	4,450	03/29/2018	JD	100	100
89-268	06/01/1989	2	ADDITIONS				100	100

CD	T	AC/SF/UN	Ngh	Inf1	Inf2	ADJ BASE	SAF	Inf3	Lpi	VC	CREDIT AMT	ADJ VALUE
100	S	40,000	WS 1.00	100	1.00	374,000	1.00	100	1.00	R03	0.85	343,430
300	A	0.046	WS 1.00	100	1.00	16,830	1.00	100	1.00	R03	0.85	770

TOTAL	42,000 SF	ZONING	FRNT	97	ASSESSED	CURRENT	PREVIOUS
Ngh	W. SCITUATE	N O T E			LAND	344,200	313,000
Inf1	FACTOR 100		BUILDING	249,300	224,900		
Inf2	PHY 100		DETACHED	0	0		
			OTHER	0	0		
TOTAL						593,500	537,900

TY	QUAL	COND	DIM/NOTE	YB	UNITS	ADJ PRICE	RCNLD

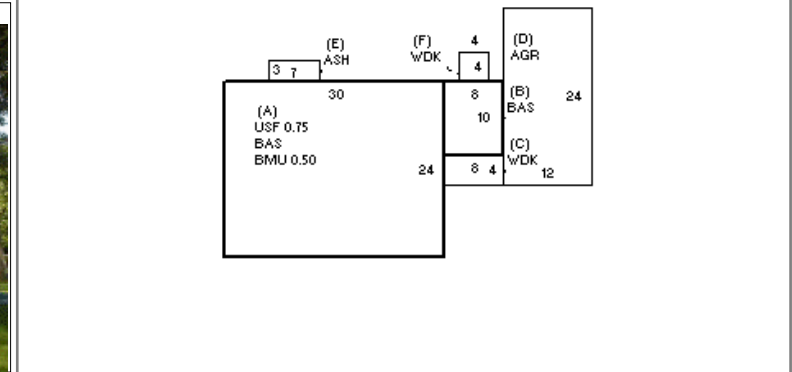

BUILDING	CD	ADJ	DESC	MEASURE	3/29/2018	JD
MODEL	1		RESIDENTIAL	LIST	3/29/2018	EST
STYLE	4	1.10	CAPE [100%]	REVIEW	3/21/2011	KT
QUALITY	A	1.00	AVERAGE [100%]			
FRAME	1	1.00	WOOD FRAME [100%]			

BLDG COMMENTS

YEAR BLT	1953	SIZE ADJ	1.000	ELEMENT	CD	DESCRIPTION	ADJ	S	BAT	T	DESCRIPTION	UNITS	YB	ADJ PRICE	RCN	TOTAL RCN	361,269
NET AREA	1,340	DETAIL ADJ	1.122	FOUNDATION	4	CONT BSMT WALL	1.00	A	BMU	N	BSMT UNFINISHED	360		63.15	22,734	CONDITION ELEM	CD
\$NLA(RCN)	\$270	OVERALL	1.000	EXT COVER	1	WD SHINGLES	1.00	A	USF	L	UPPER STORY FIN	540	1953	224.34	121,142		
CAPACITY				ROOF SHAPE	1	GABLE	1.00	+	BAS	L	BASE AREA	800	1953	246.69	197,350	EXTERIOR	
STORIES	1.75	1.00	ROOF COVER	1	ASP SHINGLES	1.00	+	WDK	N	WOOD DECK	48		38.40	1,843	INTERIOR		
ROOMS	6	1.00	FLOOR COVER	99	N/A	1.00	D	AGR	N	ATT GARAGE	288		52.22	15,038	KITCHEN		
BEDROOMS	3	1.00	INT FINISH	99	N/A	1.00	E	ASH	N	ATT SHED	21		22.33	469	BATHS		
BATHROOMS	1	1.00	HEATING/COOLING	2	HOT WATER	1.02									HEAT		
# 1/2 BATHS	0	1.00	FUEL SOURCE	99	N/A	1.00									ELECT		
TOT FIXTURES	3	\$2,693															
# UNITS	1	1.00															
																EFF.YR/AGE	1972 / 50
																COND	31 31 %
																FUNC	0
																ECON	0
																DEPR	31 % GD 69
																RCNLD	\$249,300