

Key: 1588

Town of SCITUATE - Fiscal Year 2024

10/18/2023 5:31 pm SEQ #: 1.530

LEG  
A  
L

CURRENT OWNER				PARCEL ID				LOCATION				
COREY CALVIN HERBERT III & HAYLEY CHRISTINE 80 MANN LOT RD SCITUATE, MA 02066				25-1-3-F				80 MANN LOT RD				
				TRANSFER HISTORY				DOS	T	SALE PRICE	BK-PG (Cert)	
				COREY CALVIN HERBERT III				05/13/2021	QS	715,000	(131984)	
MURTAUGH PATRICK F &				09/28/2017	QS	520,000	(125835)					
BJORKLUND J STEPHEN TR &				02/28/2017	O	460,000	(124828)					
CD	T	AC/SF/UN	Ngh	Inf1	Inf2	ADJ BASE	SAF	Inf3	Lpi	VC	CREDIT AMT	ADJ VALUE
100	S	34,628	NS	1.00	100	1.00	100	1.00	R03	0.85		337,720

L  
A  
N  
D

TOTAL	34,628 SF	ZONING	FRNT	291	ASSESSED	CURRENT	PREVIOUS
Ngh	NO. SCITUATE	N O T E			LAND	337,700	325,100
Inf1	FACTOR 100		BUILDING	418,200	371,900		
Inf2	PHY 100		DETACHED	36,100	30,600		
				OTHER	0	0	
				<b>TOTAL</b>	<b>792,000</b>	<b>727,600</b>	

D  
E  
T  
A  
C  
H  
E  
D

TY	QUAL	COND	DIM/NOTE	YB	UNITS	ADJ PRICE	RCNLD
DGF	+	1.10	10 0.90 35X26	2022	910	44.08	36,100

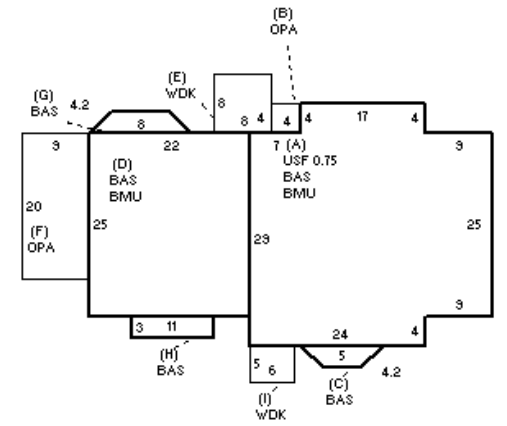

B  
U  
I  
L  
D  
I  
N  
G

BUILDING	CD	ADJ	DESC	MEASURE	8/2/2022	JD
MODEL	1		RESIDENTIAL	LIST	8/2/2022	EST
STYLE	4	1.10	CAPE [100%]	REVIEW	11/9/2022	JD
QUALITY	A	1.00	AVERAGE [100%]			
FRAME	1	1.00	WOOD FRAME [100%]			

BLDG COMMENTS  
MLS

YEAR BLT	1939	SIZE ADJ	1.000
NET AREA	2,371	DETAIL ADJ	1.122
\$NLA(RCN)	\$252	OVERALL	1.000
CAPACITY		UNITS	ADJ
STORIES		1.75	1.00
ROOMS		7	1.00
BEDROOMS		3	1.00
BATHROOMS		1	1.00
# 1/2 BATHS		1	1.00
TOT FIXTURES		5	\$4,488
# UNITS		1	1.00

ELEMENT	CD	DESCRIPTION	ADJ	S	BAT	T	DESCRIPTION	UNITS	YB	ADJ PRICE	RCN
FOUNDATION	4	CONT BSMT WALL	1.00	+	BMU	N	BSMT UNFINISHED	1,539		42.44	65,310
EXT COVER	1	WD SHINGLES	1.00	A	USF	L	UPPER STORY FIN	742	1939	199.60	148,104
ROOF SHAPE	1	GABLE	1.00	+	OPA	N	OPEN PORCH	196		51.50	10,094
ROOF COVER	1	ASPH SHINGLES	1.00	+	BAS	L	BASE AREA	1,629	1939	219.49	357,546
FLOOR COVER	24	COMB	1.00	+	WDK	N	WOOD DECK	94		38.40	3,610
INT FINISH	1	PLASTER	1.00	F21	O	FPL 2S 1OP		1		8,239.00	8,239
HEATING/COOLING	2	HOT WATER	1.02								
FUEL SOURCE	1	OIL	1.00								

TOTAL RCN	597,391
CONDITION ELEM	CD
EXTERIOR	A
INTERIOR	A
KITCHEN	G
BATHS	A
HEAT	U
ELECT	A
EFF.YR/AGE	1973 / 49
COND	30 30%
FUNC	0
ECON	0
DEPR	30 % GD 70
RCNLD	\$418,200