

Key: 162

Town of SCITUATE - Fiscal Year 2024

10/18/2023 5:31 pm SEQ #: 144

LEGAL

CURRENT OWNER				PARCEL ID				LOCATION			
CRONE GREGORY 747 COUNTRY WAY SCITUATE, MA 02066				12-3-9-0				747 COUNTRY WAY			
TRANSFER HISTORY				DOS	T	SALE PRICE	BK-PG (Cert)				
CRONE GREGORY				09/13/2022	V	700,000	57230-242				
YARDINE-YEATS RHONDA &				09/13/2022	V	1	57230-238				
JARDINE-YEATS MARIE & RHO				03/03/2021	F	1	54508-113				

CLASS	CLASS%	DESCRIPTION			BN ID	BN	CARD	
1010	100	SINGLE FAMILY				1	1 of 1	
PMT NO	PMT DT	TY	DESC	AMOUNT	INSP	BY	1st	%
23-154	02/24/2023	3	ALTERATIONS	37,000	05/22/2023	JD	100	100

LAND

CD	T	AC/SF/UN	Ngh	Infl1	Infl2	ADJ BASE	SAF	Infl3	Lpi	VC	CREDIT AMT	ADJ VALUE	
100	S	40,000	NS 1.00	100	1.00	100	1.00	336,600	1.00	90	0.90	R02 0.85	309,090
300	A	1,482	NS 1.00	100	1.00	100	1.00	11,781	1.00	70	0.70	R02 0.85	17,460

TOTAL	2.400 Acres	ZONING	FRNT	0	ASSESSED	CURRENT	PREVIOUS
Ngh	NO. SCITUATE	NOTE IN M19...INFL3=EASEMENT	LAND	326,600	348,300		
Infl1	FACTOR 100		BUILDING	395,400	187,100		
Infl2	PHY 100		DETACHED	34,600	33,000		
			OTHER	0	0		
			TOTAL	756,600	568,400		

DETACHED

TY	QUAL	COND	DIM/NOTE	YB	UNITS	ADJ PRICE	RCNLD
DGF	A	1.00	30 0.70 GARAGE		216	54.75	8,300
LBN	A	1.00	20 0.80 2SFR	1982	1,200	27.40	26,300

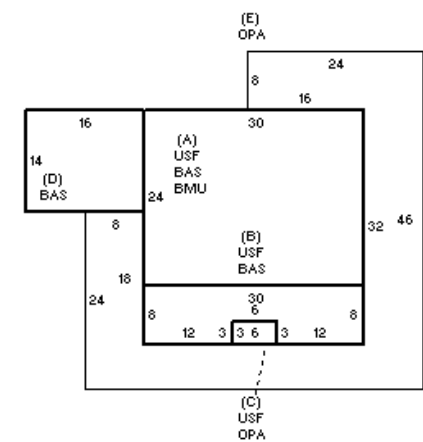

BUILDING

BUILDING	CD	ADJ	DESC	MEASURE	5/22/2023	JD
MODEL	1		RESIDENTIAL	LIST	5/22/2023	EST
STYLE	7	1.20	CONVENTIONAL [100%]	REVIEW	3/4/2011	KT
QUALITY	A	1.00	AVERAGE [100%]			
FRAME	1	1.00	WOOD FRAME [100%]			

BLDG COMMENTS		

G

YEAR BLT	1915	SIZE ADJ	1.000	ELEMENT	CD	DESCRIPTION	ADJ	S	BAT	T	DESCRIPTION	UNITS	YB	ADJ PRICE	RCN	TOTAL RCN	599,096																		
NET AREA	2,126	DETAIL ADJ	1.236	FOUNDATION	4	CONT BSMT WALL	1.00	A	BMU	N	BSMT UNFINISHED	720		52.37	37,708																				
\$NLA(RCN)	\$282	OVERALL	1.000	EXT COVER	2	CLAPBOARD	1.00	+	USF	L	UPPER STORY FIN	960	1915	224.15	215,181																				
				ROOF SHAPE	1	GABLE	1.00	+	BAS	L	BASE AREA	1,166	1915	246.48	287,395																				
				ROOF COVER	1	ASPH SHINGLES	1.00	+	OPA	N	OPEN PORCH	886		51.50	45,629																				
				FLOOR COVER	24	COMB	1.00		F21	O	FPL 2S 1OP	1		8,239.00	8,239																				
				INT FINISH	1	PLASTER	1.00																												
				HEATING/COOLING	9	WARM/COOL AIR	1.03																												
				FUEL SOURCE	1	OIL	1.00																												
				<table border="1"> <tr> <th>CONDITION ELEM</th> <th>CD</th> </tr> <tr> <td>EXTERIOR</td> <td>G</td> </tr> <tr> <td>INTERIOR</td> <td>A</td> </tr> <tr> <td>KITCHEN</td> <td>A</td> </tr> <tr> <td>BATHS</td> <td>A</td> </tr> <tr> <td>HEAT</td> <td>A</td> </tr> <tr> <td>ELECT</td> <td>A</td> </tr> </table>														CONDITION ELEM	CD	EXTERIOR	G	INTERIOR	A	KITCHEN	A	BATHS	A	HEAT	A	ELECT	A				
CONDITION ELEM	CD																																		
EXTERIOR	G																																		
INTERIOR	A																																		
KITCHEN	A																																		
BATHS	A																																		
HEAT	A																																		
ELECT	A																																		
				<table border="1"> <tr> <td>EFF.YR/AGE</td> <td colspan="2">1970 / 52</td> </tr> <tr> <td>COND</td> <td>34</td> <td>34 %</td> </tr> <tr> <td>FUNC</td> <td>0</td> <td></td> </tr> <tr> <td>ECON</td> <td>0</td> <td></td> </tr> <tr> <td>DEPR</td> <td>34</td> <td>% GD 66</td> </tr> <tr> <td>RCNLD</td> <td colspan="2">\$395,400</td> </tr> </table>														EFF.YR/AGE	1970 / 52		COND	34	34 %	FUNC	0		ECON	0		DEPR	34	% GD 66	RCNLD	\$395,400	
EFF.YR/AGE	1970 / 52																																		
COND	34	34 %																																	
FUNC	0																																		
ECON	0																																		
DEPR	34	% GD 66																																	
RCNLD	\$395,400																																		
CAPACITY				STORIES	2	1.00																													
				ROOMS	8	1.00																													
				BEDROOMS	3	1.00																													
				BATHROOMS	1	1.00																													
				# 1/2 BATHS	1	1.00																													
				TOT FIXTURES	5	\$4,944																													
				# UNITS	1	1.00																													