

Key: 1659

Town of SCITUATE - Fiscal Year 2024

10/18/2023 5:31 pm SEQ #: 1.600

LEG
A
L

| CURRENT OWNER | | | | PARCEL ID | | | | LOCATION | | | |
|---|--|--|--|------------|----|------------|--------------|-------------------|--|--|--|
| SUGAR JOSEPH P & KAREN A 127 BOOTH HILL ROAD SCITUATE, MA 02066 | | | | 19-1-8-0 | | | | 127 BOOTH HILL RD | | | |
| TRANSFER HISTORY | | | | DOS | T | SALE PRICE | BK-PG (Cert) | | | | |
| SUGAR JOSEPH P & KAREN A | | | | 04/28/1995 | QS | 190,000 | 13550-39 | | | | |
| EMMETT COLLEEN & SPECHT N | | | | 10/15/1993 | QS | 165,000 | 12295-312 | | | | |
| DONOVAN JEREMIAH A III & | | | | 12/23/1986 | XX | | 7366-234 | | | | |

| CLASS | CLASS% | DESCRIPTION | | | BN ID | BN | CARD | |
|--------|--------|---------------|------|--------|-------|----|--------|---|
| 1010 | 100 | SINGLE FAMILY | | | | 1 | 1 of 1 | |
| PMT NO | PMT DT | TY | DESC | AMOUNT | INSP | BY | 1st | % |
| | | | | | | | | |

L
A
N
D

| CD | T | AC/SF/UN | Ngh | Infl1 | Infl2 | ADJ BASE | SAF | Infl3 | Lpi | VC | CREDIT AMT | ADJ VALUE |
|-----|---|----------|---------|-------|-------|----------|------|-------|------|-----|------------|-----------|
| 100 | S | 13,400 | WS 1.00 | 100 | 1.00 | 374,000 | 2.71 | 100 | 1.00 | R07 | 0.85 | 312,280 |

| TOTAL | 13,416 SF | ZONING | W. SCITUATE | FRNT | 158 | ASSESSED | CURRENT | PREVIOUS |
|-------|-------------|--------|-------------|---------|---------|----------|---------|----------|
| Ngh | W. SCITUATE | NOTE | | LAND | 312,300 | 283,900 | | |
| Infl1 | FACTOR 100 | | BUILDING | 242,500 | 228,400 | | | |
| Infl2 | PHY 100 | | DETACHED | 0 | 0 | | | |
| | | | OTHER | 0 | 0 | | | |
| | | | | TOTAL | 554,800 | 512,300 | | |

D
E
T
A
C
H
E
D

| TY | QUAL | COND | DIM/NOTE | YB | UNITS | ADJ PRICE | RCNLD |
|----|------|------|----------|----|-------|-----------|-------|
| | | | | | | | |

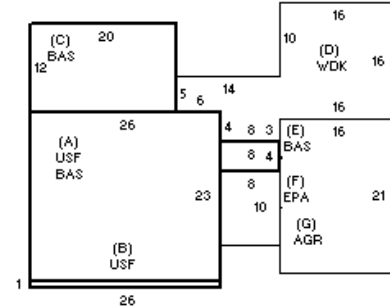

B
U
I
L
D
I
N
G

| BUILDING | CD | ADJ | DESC | MEASURE | 8/17/2010 | PL |
|----------|----|------|-------------------|---------|-----------|-----|
| MODEL | 1 | | RESIDENTIAL | LIST | 8/17/2010 | EST |
| STYLE | 5 | 1.00 | COLONIAL [100%] | REVIEW | 3/21/2011 | KT |
| QUALITY | A | 1.00 | AVERAGE [100%] | | | |
| FRAME | 1 | 1.00 | WOOD FRAME [100%] | | | |

BLDG COMMENTS

| YEAR BLT | 1957 | SIZE ADJ | 1.000 | ELEMENT | CD | DESCRIPTION | ADJ | S | BAT | T | DESCRIPTION | UNITS | YB | ADJ PRICE | RCN | TOTAL RCN | 351,455 | | | |
|------------|-------|------------|-------|-----------------|----|---------------|------|---|-----|---|-----------------|-------|------|-----------|---------|----------------|---------|------------|------------|--|
| NET AREA | 1,494 | DETAIL ADJ | 0.980 | FOUNDATION | 1 | PIER | 0.98 | + | BAS | L | BASE AREA | 870 | 1957 | 209.89 | 182,604 | CONDITION ELEM | CD | | | |
| \$NLA(RCN) | \$235 | OVERALL | 1.000 | EXT COVER | 2 | CLAPBOARD | 1.00 | + | USF | L | UPPER STORY FIN | 624 | 1957 | 190.87 | 119,104 | EXTERIOR | | | | |
| | | | | ROOF SHAPE | 1 | GABLE | 1.00 | D | WDK | N | WOOD DECK | 358 | | 38.40 | 13,747 | INTERIOR | | | | |
| | | | | ROOF COVER | 1 | ASPH SHINGLES | 1.00 | F | EPA | N | ENCLOSED PORCH | 80 | | 90.20 | 7,216 | KITCHEN | | | | |
| | | | | FLOOR COVER | 99 | N/A | 1.00 | G | AGR | N | ATT GARAGE | 336 | | 49.48 | 16,625 | BATHS | | | | |
| | | | | INT FINISH | 99 | N/A | 1.00 | | F21 | O | FPL 2S 1OP | 1 | | 8,239.00 | 8,239 | HEAT | | | | |
| | | | | HEATING/COOLING | 1 | FORCED AIR | 1.00 | | | | | | | | | ELECT | | | | |
| | | | | FUEL SOURCE | 99 | N/A | 1.00 | | | | | | | | | | | | | |
| | | | | | | | | | | | | | | | | | | EFF.YR/AGE | 1972 / 50 | |
| | | | | | | | | | | | | | | | | | | COND | 31 31 % | |
| | | | | | | | | | | | | | | | | | | FUNC | 0 | |
| | | | | | | | | | | | | | | | | | | ECON | 0 | |
| | | | | | | | | | | | | | | | | | | DEPR | 31 % GD 69 | |
| | | | | | | | | | | | | | | | | | | RCNLD | \$242,500 | |