

Key: 1876

Town of SCITUATE - Fiscal Year 2024

10/18/2023 5:31 pm SEQ #: 1.802

LEGAL

LAND

CURRENT OWNER				PARCEL ID				LOCATION			
LEMAY ERIC & WEBBER CHRISTINE C 53 GROVE ST SCITUATE, MA 02066				31-1-17-0				53 GROVE ST			
TRANSFER HISTORY				DOS	T	SALE PRICE	BK-PG (Cert)				
LEMAY ERIC & YOUNG EDWARD W				12/10/2021	QS	529,000	56151-231				
YOUNG EDWARD W				04/14/2008	H	1	35846-155				
YOUNG CAROLE R & EDWARD W				04/12/1988	QS		8386-222				

CLASS	CLASS%	DESCRIPTION			BN ID	BN	CARD	
1010	100	SINGLE FAMILY				1	1 of 1	
PMT NO	PMT DT	TY	DESC	AMOUNT	INSP	BY	1st	%
E22-0853	10/05/2022	3	ALTERATIONS	4,000	03/29/2023	JD	100	100
		7	OTHERS		08/04/2022	JD	100	100
16-39	01/28/2016	3	ALTERATIONS	8,000	06/29/2016	SJ	100	100
02-685	12/05/2002	3	ALTERATIONS				100	100
96-181	05/01/1996	3	ALTERATIONS				100	100

CD	T	AC/SF/UN	Ngh	Infl1	Infl2	ADJ BASE	SAF	Infl3	Lpi	VC	CREDIT AMT	ADJ VALUE
100	S	40,000	WS 1.00	100	1.00	374,000	1.00	100	1.00	R03	0.85	343,430
300	A	1,012	WS 1.00	100	1.00	16,830	1.00	100	1.00	R03	0.85	17,030

TOTAL	1.930 Acres	ZONING	FRNT	78	ASSESSED	CURRENT	PREVIOUS
Ngh	W. SCITUATE	NOTE REMOVED INFL3 (FY12)	LAND	360,500	328,600		
Infl1	FACTOR 100		BUILDING	285,600	238,000		
Infl2	PHY 100		DETACHED	0	0		
			OTHER	0	0		
			TOTAL	646,100	566,600		

TY	QUAL	COND	DIM/NOTE	YB	UNITS	ADJ PRICE	RCNLD



BLDG COMMENTS
mls

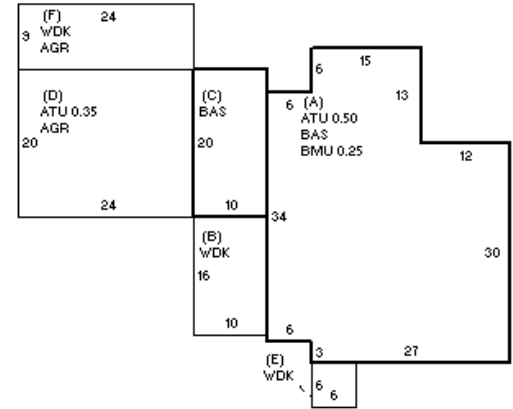

DETACHED

BUILDING

YEAR BLT	1939	SIZE ADJ	1.000	ELEMENT	CD	DESCRIPTION	ADJ	S	BAT	T	DESCRIPTION	UNITS	YB	ADJ PRICE	RCN	TOTAL RCN	446,221
NET AREA	1,409	DETAIL ADJ	1.122	FOUNDATION	4	CONT BSMT WALL	1.00	A	BMU	N	BSMT UNFINISHED	302		63.15	19,071		
\$NLA(RCN)	\$317	OVERALL	1.000	EXT COVER	2	CLAPBOARD	1.00	+	ATU	N	ATTIC UNF	773		37.00	28,601		
				ROOF SHAPE	1	GABLE	1.00	+	WDK	N	WOOD DECK	412		38.40	15,821		
				ROOF COVER	1	ASPH SHINGLES	1.00	+	BAS	L	BASE AREA	1,409	1939	243.61	343,251		
				FLOOR COVER	24	COMB	1.00	+	AGR	N	ATT GARAGE	696		41.01	28,545		
				INT FINISH	1	PLASTER	1.00	F21	O	FPL 2S 1OP	1		8,239.00	8,239			
				HEATING/COOLING	2	HOT WATER	1.02										
				FUEL SOURCE	1	OIL	1.00										

CONDITION ELEM	CD
EXTERIOR	F
INTERIOR	F
KITCHEN	A
BATHS	A
HEAT	A
ELECT	U

EFF.YR/AGE	1968 / 54
COND	36 36%
FUNC	0
ECON	0
DEPR	36 % GD 64
RCNLD	\$285,600